

USAREC Regulation 601-210

Personnel Procurement

Enlistment & Accessions Processing

**Headquarters
United States Army Recruiting Command
1307 3rd Avenue
Fort Knox, Kentucky 40121-2725
20 July 2018**

UNCLASSIFIED

SUMMARY of CHANGE

UR 601-210

Enlistment and Accessions Processing.

This Administrative Revision (Version 7.7), dated 19 Jun 2020 -

- o Changed version 7.6 to 7.7 Summary of Changes
- o 5-1.5 q (7) removed “or without the applicant physically present.”
- o 7-4.4 (3)(a)- “Don’t know –if recruiters do did”
- o 7-4.7 c- added paragraph
- o V-3 e. changed “all source docs are obtained, verified and uploaded reservation can be pulled”
- o V-3 e. added NOTE: When the ROC is called for assistance.
- o V-3 o. (3). removed “the applicant must be present and with the recruiter.”

Headquarters
United States Army Recruiting Command
1307 3rd Avenue
Fort Knox, Kentucky 40121-2725
1 July 2018

*USAREC Regulation 601-210

Effective 20 July 2018

Personnel Procurement

Enlistment & Accessions Processing

For the Commander:

Brad P. Luebbert
Colonel, GS
Chief of Staff

Official:

Ronnie L. Creech
Ronnie L. Creech
Assistant Chief of Staff, CIO/G6

History. This publication is version 7.4, an admin revision of a major revision 7.0 dated 20 July 2018.

Summary. This regulation establishes the policies and procedures for processing applicants for enlistment into the U.S. Army.

Applicability. This regulation applies to all military and civilian personnel assigned, attached, or detailed to the U.S. Army

Recruiting Command. Portions of this regulation that prescribe specific conduct are punitive and violations of these provisions may subject offenders or non-judicial or judicial action under the Uniform Code of Military Justice.

Proponent and exception authority. The proponent of this regulation is the Assistant Chief of Staff, G3. The proponent has the authority to approve exceptions to this regulation that are consistent with controlling law and regulation.

Army management control process. This regulation contains management control provisions in accordance with AR 11-2, but does not identify key management controls that must be evaluated.

Supplementation. Supplementation of this regulation is prohibited.

Relation to USAREC Reg 10-1.

This publication establishes policies and procedures regarding the Enlistment, Accessions, and Processing procedures according to UR 10-1, para 3-14.

Suggested improvements. Users are invited to send comments and suggested improvements on DA Form 2028 (Recommended Changes to Publications and Blank Forms) directly to HQ USAREC, ATTN: RCRO-EEP, 1307 3rd Avenue, Fort Knox, KY 40121-2725.

Distribution. This publication is available in electronic media only and is intended for command distribution levels A and Y

*This regulation update supersedes USAREC Regulation 601-210 (7.6), dated 18 December 2019.

UNCLASSIFIED

Contents (Listed by paragraph and page number)

- Purpose • 1, *page 1*
- References • 2, *page 1*
- Explanation of Abbreviations and Terms • 3, *page 1*
- Policy • 4, *page 1*
- Responsibilities for Recruiting Personnel • 5, *page 1*
- Procedures • 6, *page 6*
- Recruiting Standards Program • 7, *page 6*

Appendixes

- A. References, *page 17*
- B. Recruit Quota System (REQUEST) Procedures, *page 23*
- C. Live Scan (LS), *page 24*
- D. Quality Control (QC) Procedures and Scheduling of Applicants, *page 26*
- E. Procedures for Enlistment into the Delayed Entry Program/Delayed Training Program/Delayed Status (DEP/DTP/DS), *page 30*
- F. Procedures for Enlisting Prior Service and Glossary Non-Prior Service (Regular Army), *page 33*
- G. Applicant Background Screening (ABS): Technical (tech) Check and National Agency Check and Local Check (NACLIC), *page 39*
- H. Change in Active Duty Date and DEP/DTP Renegotiation, *page 46*
- I. Active and Reserve Component Separations, *page 48*
- J. Army Reserve Specific Processing, *page 58*
- K. Regular Army Options and Incentives, *page 64*
- L. Overseas Processing Procedures, *page 70*
- M. Waiver Procedures, *page 72*
- N. Education Credentialing, *page 78*
- O. Future Soldier (FS) Management, *page 88*
- P. DEP/DTP-Out Procedures, *page 96*
- Q. Required USMEPCOM Daily Reports and GCRC End of Day Report Records, *page 99*
- R. Government Meals and Lodging Procedures, *page 100*
- S. Electronic Records Management, *page 102*
- T. U.S. Army Recruiting Command Liaisons at U.S. Army Reception Battalions (RECBN), *page 103*
- U. Occupational Physical Assessment Test (OPAT), *page 105*
- V. Temporary Reservation Procedures, *page 108*

Figures List

- Figure 1 • USAREC Recruiting Misconduct Flow chart, *page 16*
- Figure J-1 • Army Reserve ROTC SMP Processing Flowchart, *page 63*
- Figure K-1 • OCS & WOFT Selection Process, *page 69*

Figure N-1 • Tier Evaluation Workflow, *page 86*

Figure N-2 • Education Matrix, *page 87*

Figure O-1 • FSTP Decision Matrix, *page 93*

Tables List

Table F-1 • Standard Training (BCT/AIT) shippers list, page 39

Table F-2 • Non-Army Installation AIT RECBN list for AIT, page 39

Table I-1 • Basis for Separation and required documentation, page 53-54

Table I-2 • Authorities for Approval/Disapproval of DEP/DTP Separation Requests, page 55

Table I-3 • Separation Authority, page 56

Table I-4 • Separation Order Formats Overview, page 57

Table K-1 • ESL Calculation, page 64

Table O-1 • Future Soldier Asset Inventory (FSAI), page 92

Table O-2 • Future Soldier Status Code Examples, page 96

Table P-2 • USAREC Liaisons, page 100

Glossary

1. Purpose

- a. Establish policies, responsibilities, and procedures for processing applicants for enlistment and accession in the Army and ensuring accuracy and completeness of enlistment records.
- b. Contains instructions to determine the eligibility and suitability for enlistment processing of Regular Army (RA) and Army Reserve (AR) applicants.
- c. Provides ready references for functions and processes performed by assigned United States Army Recruiting Command (USAREC) recruiting personnel.
- d. In the case of conflict between this regulation and other USAREC regulations or directives that address applicant processing procedures contact G3, Enlistment Eligibility Processing Division (EEPD), and Policy Branch.
- e. Contains supplementary information to AR 601-210.

2. References

For required and related publications and prescribed and referenced forms, see appendix A.

3. Explanation of Abbreviations and Terms

The Glossary Sections I & II (Abbreviations and Terms) explain abbreviations and special terms used within this regulation.

4. Policy

- a. This regulation establishes policies, responsibilities, and procedures for processing applicants for enlistment in the U.S. Army and quality control (QC) of enlistment records.
- b. This regulation also establishes responsibilities and procedures for station commanders (SCs) and recruiters using the Future Soldier Remote Reservation Systems (FSR2S).
- c. This regulation contains instructions for processing Regular Army (RA) and Army Reserve (AR) waiver applications to determine eligibility for enlistment.
- d. This regulation will enable guidance counselors (GCs) to provide quality service to applicants processed through Military Entrance Processing Stations (MEPS). Efficient, responsive applicant processing promotes mission accomplishment and the smooth flow of information throughout the command.
- e. This regulation provides ready references for functions performed by GCs.
- f. In case of conflict between this regulation and other United States Army Recruiting Command (USAREC) regulations or directives that address GC procedures, call through channels to the G3, Enlistment Eligibility and Processing Division, Policy Branch.

5. Responsibilities for Recruiting Personnel

5-1.1 Purpose

This section establishes policies and procedures for assigned USAREC personnel in specified roles within the processing and operations functions to ensure the accuracy and completeness of enlistment records and legal enlistments. All Cdrs will ensure compliance within this regulation.

- a. This regulation establishes policies, responsibilities, and procedures for processing applicants for enlistment in the U.S. Army and quality control (QC) of enlistment records.
- b. This regulation also establishes responsibilities and procedures for station commanders (SCs) and recruiters using the Temporary Reservation System.
- c. This regulation contains instructions for processing Regular Army (RA) and Army Reserve (AR) waiver applications to determine eligibility for enlistment.

5-1.2

- a. This regulation will enable guidance counselors (GCs) to provide quality service to applicants processed through Military Entrance Processing Stations (MEPS). Efficient, responsive applicant processing promotes mission accomplishment and the smooth flow of information throughout the command.
- b. This regulation provides ready references for functions performed by GCs.
- c. In case of conflict between this regulation and other United States Army Recruiting Command (USAREC) regulations or directives that address GC procedures, call through channels to the G3, Enlistment Eligibility Processing Division, Policy Branch.

5-1.3 Policy

- a. This regulation establishes policies for the performance of those GC duties which are mandatory elements in enlisting qualified men and women into the Army and provides procedures for the performance of other duties.
- b. This regulation establishes policies for GC and operations functions and procedures.
- c. GCs must thoroughly understand all phases of the recruiting cycle. They must be self-starters and display outstanding character traits, initiative, self-discipline, and integrity. They must be capable and persuasive communicators, not only with applicants, but also with recruiters and MEPS personnel. Under no circumstances will a relieved recruiter serve in an operations section or as a GC.
- d. All workflow histories within the Army Recruiting Information Support System (ARISS), Guidance Counselor Resource Center (GCRc), and Recruiter/Leaders Zone (R/LZ) are considered for official use only and will not be released to anyone outside of USAREC.
- e. Access to information that is a work product within the USAREC chain of command is restricted. Under no circumstances will an applicant be provided a copy of any workflow information. If an applicant requests the name of an approval authority they will only be given the position title such as commanding general or deputy commanding general. If an applicant or parent requests further explanation they will be referred to the company or battalion commander. Applicants or parents will not be referred to higher headquarters or provided with e-mail addresses or phone numbers of Headquarters, U.S. Army Recruiting Command (HQ USAREC) personnel.

5-1.4 Prerequisites for selection as GC and operations noncommissioned officer

- a. Soldiers selected for assignment to guidance counselor and operations noncommissioned officer positions must meet the following criteria.
 - (1) Must have successfully completed the Station Commander Course.
 - (2) Must successfully complete the Guidance Counselor and Operations Course (GCOC) at the Recruiting and Retention College.
- b. NCOs and DA Civilians assigned to SGC, GC, and operations NCO positions must possess the V7 additional skill identifier (ASI).

5-1.5 Duties and Responsibilities

- a. The Assistant Chief of Staff, G3 will:
 - (1) Implement and administer this regulation and serve as the functional proponent of the Recruit Quota System (REQUEST).
 - (2) Clarify all conduct or waiver issues (EPPD, Waivers Branch).
 - (3) Process all exception to policy (ETP) requests for Joint Personnel Adjudication System (JPAS); Live Scan (LS) fingerprint (FP) results, Personnel Reliability Program (PRP) qualifications for applicable Military Occupational Specialties (MOS), top secret clearance issues and language ETP (EPPD, Background Screening Branch).
 - (4) Announce Special Mission board dates and board ready packet receipt cutoff dates for selection boards (Special Programs and Boards).
 - (5) Notify each Bde of applicants who are selected and non-selected (WOFT/OCS), upon approval of the USAREC level board results (Special Programs and Boards).
- b. The Staff Judge Advocate (SJA) provides the command legal advice on Processing Procedure Reviews (PPR), and Recruiter Misconduct Investigations (see chapter 7 for additional duties and responsibilities).
- c. The Office of the Inspector General (IG) is responsible for evaluating the regulation's effectiveness and for monitoring adherence to its policies and provisions during unit or staff IG inspections.
- d. Director, Recruiting Standards Division (RSD) is responsible for the training, inspection and investigation of subordinate units and assigned personnel to verify adherence with all applicable laws, regulation or policies that regulate or direct recruiting activities through the Recruiting Standards Program (RSP) (see chapter 7 for additional duties and responsibilities) and will provide support, when requested by Cdrs, to assist or conduct investigations of adherence to applicable law, regulation, or policy that regulates or directs recruiting activities.
- e. The Assistant Chief of Staff, G1, is responsible for managing the selection, screening, and assignment of recruiting personnel.
- f. The Assistant Chief of Staff, G6, is responsible for the supervision, coordination, and administration of REQUEST operations.
- g. The Commandant, Recruiting and Retention College is responsible for the institutional training of all recruiters, guidance counselors (GC), senior guidance counselors (SGC) and Cdrs/NCO advisors.
- h. Bde Cdrs will provide subordinate Bns the necessary training, management, operational oversight and command emphasis to ensure compliance with this regulation through the USAREC organizational inspection

program (OIP). This includes, but is not limited to: mission assignment, budget allocation, personnel and equipment resourcing, leader training and certification, recruiter development, waiver and exceptions processing, renegotiation and loss processing, production management, policy establishment, marketing/advertising resourcing and oversight.

(1) Ensure that the Bde completes the end of day processing and shipping close-out with USAREC through EEPD, Recruiting Operations Center (ROC).

(2) Provide oversight of subordinate Bn's enforcement of RSP (See chapter 7 for additional duties and responsibilities).

i. Bde Educational Services Specialists (ESS)

(1) Serves as the Bde Cdr's functional expert on all matters relating to education enlistment eligibility and education credentials.

(2) In the absence of a Bn ESS, the Bde ESS serves as the evaluating official for tier evaluations as required and conducts Tier/DoD education code classification evaluations for those applicants whose school or program require further evaluation to determine enlistment Tier/DoD education code classification status.

j. Bn Cdrs are responsible for all enlistment and accession activities prescribed in this regulation and will:

(1) Retain overall responsibility for applicant processing.

(2) Provide the necessary training, management, and command emphasis to ensure compliance with this regulation.

(3) Establish policies and procedures for sustainment training of all assigned GCs and Bn Ops.

(4) Establish a projection cutoff time that will allow GCs sufficient time to perform a proper Quality Control (QC) based upon the supporting MEPS' Standard Operating Procedure (SOP).

(5) Appoint an Applicant Background Screening Manager (ABSM) as the primary point of contact for all applicant background screening (ABS) program issues and maintain overall responsibility for the ABS program in the Bn. Bn Cdrs will appoint, by duty memorandum, an Ops NCO or civilian and alternate to perform duties as the ABSM.

(6) Appoint a Special Missions program OIC or NCOIC to serve as a Special Mission liaison and point of contact for the unit.

(7) Appoint and conduct recommendation boards for OCS and WOFT IAW AR 601-210, OCS and WOFT enlistment programs, and this regulation.

(8) Execute the unit RSP (see chapter 7 for additional duties and responsibilities).

(9) Serves as approval authority for all tier evaluations in the Bn.

(10) Ensure suspected or recruiter misconduct (RM) allegations are reported IAW chapter 7 of this regulation.

(11) Initiate any required investigation if presented by a MEPS through the UMF 601-23-E concerning any alleged misconducts with the enlistment process.

(12) Ensure the conduct of the unit Volume II analysis and reporting to monitor for disqualification trends.

(13) Attend Inter-service Recruitment Committee (IRC), for each assigned MEPS every quarter. Maintain minutes from IRC for the current year and previous year at Battalion Operations.

k. Bn S-3/Operations SGMs or NCOICs will:

(1) Monitor the Bn ABS program to ensure compliance with this regulation.

(2) Ensure that ABSM reviews the Clearance Status page daily in Report Management Zone (RMZ) to verify the previous day's submissions from the unit's supporting MEPS.

(3) Monitor Erroneous Enlistment Reports (EERs) (UF 601-210.06) to identify training base disqualification trends and in.

(4) Report all 20 point increases on the Armed Services Vocational Aptitude Battery (ASVAB) to the Bn XO.

(5) Report all PPR and RM allegations to the responsible Bn XO.

(6) Ensure the daily completion of applicant enlistment record QC for all assigned MEPS.

(7) Inspect each supporting GC shop semi-annually using UF 601-210.05.

(8) Validate the completion of processing and enlistment record completeness for all courtesy shippers IAW appendix P-4.

(9) Maintain and update the Ship without Advanced Reservation (SWAR) Program as part of the Alternate Training Program (ATP) IAW appendix J-2b.

(10) Track all qualified not enlisted (QNE) to identify trends and report the date to the Bn XO for training indicators.

(11) Maintain minutes from IRC for the current year and previous year.

l. Bn ESS will:

(1) Serve as the functional expert for interpretation and application of education qualification for the Bn.

(2) Conduct physical on-site visits and complete School Profile Evaluation (UF 601-210.40) as required for non-regionally accredited non-public schools, non-public adult or alternative education schools.

- (3) Complete all Tier Evaluation Workflows submitted by recruiting personnel for all;
 - (a) Applicants with education credentials from DoD Education Code "TE" schools in Headquarters Support System/Force Structure and Zip Code Realignment System (HSS/FAZR).
 - (b) Recruiter manually entered schools processing for enlistment.
 - (4) Conduct further evaluations for programs and/or applicants identified as requiring further review for verification of education credentials.
 - (5) Update and maintain school detail information within HSS/FAZR School sections.
 - (6) Serves as the primary evaluating official on all Education Evaluation Worksheets (Tier Evaluation workflow is the preferred method but UF 601-210.41 can be used as back up).
- NOTE:** SGCs play a key role in enforcing policy. The purpose is to ensure every applicant receives "red-carpet treatment."

m. Senior Guidance Counselor (SGC) will:

- (1) Ensure applicants meet basic eligibility for enlistment, specific options, MOS, and assignment prior to enlistment.
- (2) Serve as the primary liaison between the Bn and the supporting MEPS.
- (3) Provide the Bn a copy of the existing supporting MEPS SOP that reflects the respective MEPS' processing operations.
- (4) Monitor and report all processing walk-ins, add-ons, and no-shows daily for negative trends IAW MEPCOM policies and local MEPS SOP and QNEs to the respective Bn Ops.
- (5) Monitor Prior Service (PS) verification system as outlined in AR 601-210, chapter 3-26.
- (6) Ensure the correct background screening path is submitted/accepted IAW appendix G.
- (7) Supervise the operation of REQUEST in the GC shop.
- (8) Report all 20 point increases and known confirmation test failures on the ASVAB to the Bn XO.
- (9) Report all RM allegations and all suspected PPRs as outline in Chapter 7-2.2 and Chapter 7-2.3 to the responsible Bn XO.
- (10) Validate the required documentation for Applicant and Shipper Meals and Lodging and required Shipper Reports IAW applicable MEPCOM policy or MEPS SOP IAW appendix R.
- (11) Ensure the training of all GCs on all programs and options. SGC will conduct deliberate GC sustainment training and After Action Reviews (AARs) monthly.
- (12) Conduct corrective training on all reported EERs (UF 601-210.06) and provide the Bn with a copy of training documentation.
- (13) Inform the Bn Cdr when presented with information from MEPS through UMF 601-23-E concerning any alleged misconducts with the enlistment process.
- (14) Verify daily that all processed applicants have a disposition code entered in GCRC Select -A-Person screen (see Q-5 for disposition codes).
- (15) Ensure that the following MIRS reports are generated and reviewed daily during GC shop opening: MIRS Report 18 - Daily HIV Report (USMEPCOM PCN ZHM005), MIRS Report 9 - Daily DAT Report (USMEPCOM PCN ZHM002), MIRS Report 23 - Daily ENTNAC Submission Report (USMEPCOM PCN BIR), Daily UMF 727-E – MEPS Processing List.
- (16) Validate the completion of processing and records build for all courtesy shippers IAW appendix P-4.
- (17) Upload documents in the correct ERM folders.

NOTE: At no time will an applicant be enlisted in the DEP/DTP/DS with a "No-Go".

NOTE: All documents must be uploaded in the correct folder IAW associated drop-down menu. At NO TIME should any documents be uploaded in ERM that are not associated with the folder drop-down menu. For example: Hot Seat Checklist, blank documents, BDE/BN/Co/station questionnaires, 16 questions, etc. They are not authorized ERM documents. It is imperative that uploading is completed professionally and IAW current guidance.

n. GCs (RA, AR, or Civilian) will:

- (1) Ensure applicants meet basic eligibility for enlistment, specific options, MOS, and assignment (if applicable) prior to enlistment.
- (2) Validate that all enlistment records are complete and accurate IAW appendix D prior to enlistment.
- (3) Review and verify temporary reservations in REQUEST for accuracy and qualifications before making permanent reservation and enlistment IAW appendix B and E. Ensure each applicant meets selected option prerequisites as established by DA Pam 611-21 (Smart Book), REQUEST qualifications, AR 601-210, and applicable USAREC Messages, Fragmentary Orders and Flash Messages.
- (4) QC the applicant record within 24 hours, or on the first duty day after the record populates the inbox before processing the record for MOS selection and enlistment.
- (5) Report all suspected PPRs and/or RM allegations to the SGC.

(6) Deny enlistment to any applicant with incomplete or erroneous records or no LS results. Inform applicants of any disqualification.

(7) Advise all applicants that their FPs are checked against Federal Bureau of Investigation (FBI). Concealed records may result in a discharge from the RA or AR.

(8) Ensure that the correct background screening path is submitted IAW appendix G.

(9) For PS applicants with remaining Military Service Obligation (MSO), forward a copy of the DD 4 series along with the DD 368 to the applicant's unit within 24 hours of the Oath of Enlistment IAW appendix F.

(10) Upload documents in the correct Electronic Records Management (ERM) folders.

o. Army Reception Battalion (RECBN) Liaisons will:

(1) Retrieve necessary system data to verify and resolve disqualifications (if possible).

(2) Provide feedback information to USAREC on invalid data and accession flow (see appendix T).

p. Company Cdrs will:

(1) Provide the necessary training, management, and command emphasis to ensure compliance with this regulation.

(2) Report all PPRs and RM allegations to the appropriate Bn reporting official.

(3) Review Volume II analysis and reporting on a monthly basis and implement measures to correct negative trends.

(4) Analyze FS Ship potential codes (green, amber, and red) in LZ tracking log to ensure proper management and follow-up.

(5) Process FSs' separation requests utilizing the Separation request (UF 601-201.21) IAW unit SOP or policy.

(6) Validate and sign the Advanced Rank Verification (UF 601-210.23) for FSs who qualify for advanced enlistment rank.

(7) Contact Bn Ops on ship day to validate all FS shippers and report no shows IAW unit SOP or policy.

(8) Validate that all FSs have signed a Recruit/Trainee Prohibited Activities Acknowledgement (DD 2983) by the first visit or meeting following enlistment and the form is uploaded in ERM and remains on file until the FS enters Active Duty (AD).

q. Station Commanders and recruiters will:

(1) Ensure applicants meet basic eligibility for enlistment prior to projecting for MEPS processing.

(2) Report all PPRs and RM allegations to the Company Cdr.

(3) Receive, verify, and upload all required original source documents in the applicant's ERM. Station commanders will ensure the documents are legible, are IAW AR 601-210, chapter 2, and have the required file number(s) and government seals (if applicable).

(a) Source documents will not be destroyed.

(b) Source documents will not be kept at the station or at a MEPS.

(c) Source documents will be given back to the applicant/FS immediately after verification and uploaded ERM.

(d) Source documents that have been "abandoned" and cannot be returned to the owner will be mailed to the issuing document's office by certified mail by the station commander or recruiter.

(4) FP all applicants that agree to enlist to initiate LS processing.

(5) Station commander or designated representative authorizes the LS for applicants.

(6) Ensure FPs on any applicant are not submitted solely to determine if the individual is morally qualified for enlistment. Recruiters will not conduct LS processing of FPs on themselves, family members (not processing for enlistment), other recruiters, anyone not pursuing enlistment in the RA or AR or any FS pending shipment for any reason.

(7) Review MOS qualifications with the applicant to verify qualification for the MOS before making a temporary reservation and not make a temporary reservation with known discrepancies.

(8) Ensure a temporary reservation is not created until all source documents are obtained and verified IAW AR 601-210, chapters 2 and 3 and uploaded in ERM.

(9) Inform the applicant that the temporary reservation is valid for only seven (7) days and is contingent upon the applicant qualifying for enlistment. The applicant must meet mental, medical, and conduct qualifications and any additional MOS requirements.

(10) Complete any required applicant waiver or suitability review IAW AR 601-210, chapter 4 before making a temporary reservation in REQUEST.

(11) Recruiters will project all applicants via RZ. Ensure that applicants' records projected for enlistment are complete and accurate with all supporting documents uploaded in ERM.

(12) Station commander or designated representative will conduct a complete QC validation for each applicant record prior to projection of the record for MEPS processing. The station commander, or designated representative, will place comments in the record through LZ in the station commander comments section verifying that the QC

was conducted and that the record is prepared for MEPS processing.

(13) Ensure applicants are not transported to MEPS or lodging for the purpose of processing to enlist without the applicant's GCRc record in a 'Go' status and valid LS results returned.

(14) Ensure FS signs the DD 2983 NLT the first visit or meeting with the FS following enlistment.

(15) Review the LZ FS Tracking Log ensuring height, weight, ship potential codes, Occupational Physical Assessment Test (OPAT), remarks, and next and last actions are updated IAW unit SOP or policy.

(16) Station commander will complete an UF 601-210.23 on each FS qualifying for an advanced enlistment rank IAW AR 601-210, chapter 2-18 and forward to Company Cdr for digital signature.

(17) Ensure the FS receives an RPI 200, FS Welcome Kit.

(18) Ensure each FS signs UF 601-210.24 (US Army FS -Physical Training Program Statement) prior to each organized PT session.

(19) Conduct all required Leader Based Training with the FS (SHARP, Army Suicide Prevention and Resiliency) outlined on the G3 Programs IKROme site, under the FS Training Program (FSTP) tab.

(20) Validate the enlistment record prior to shipping of the FS.

(21) Disposition of enlistment records/source documents following enlistment in the DEP (Delayed Entry)/DTP (Delayed Training Program)/DS (Delayed Status):

(a) All enlistment records will be maintained in ERM.

(b) Documents received after enlistment/accession (HS diploma, driver's license/state identification, dependent verification, etc.) will be uploaded into the appropriate folder in ERM, and original source documents will be returned to the FS.

(22) Complete ELCT/ALCPT testing prior to a permanent reservation being made for those required to test.

(23) Station commander or designated representative completes the processing and records build for all courtesy shippers IAW appendix P-4.

(24) Notifies the applicable Troop Program Unit (TPU) when a new AR Soldier enlists. The recruiter schedules and physically escorts the new Soldier to the Reserve Center to meet in-processing personnel during a scheduled unit battle assembly.

(25) Execute all required DEP/DTP out procedures IAW appendix P.

NOTE: All documents must be uploaded in the correct folder IAW associated drop-down menu. At NO TIME should any documents be uploaded in ERM that are not associated with the folder drop-down menu. For example: Hot Seat Checklist, blank documents, BDE/BN/Co/station questionnaires, 16 questions, etc. They are not authorized ERM documents. It is imperative that uploading is completed professionally and IAW current guidance.

6. Procedures

Specific procedures of this regulation are contained in the appendices and figures that follow.

7. Recruiting Standards Program

7-1.1 Purpose

Prescribe responsibilities associated with the Recruiting Standards Program (RSP), policies, procedures, reporting, processing, investigating, and disposing of allegations of Processing Procedure Reviews (PPR) and Recruiter Misconduct (RM) within USAREC. The RSP ensures the integrity of the recruiting process within USAREC. RSP adherence eliminates systemic deficiencies in the recruiting process to prevent erroneous or fraudulent enlistments.

7-1.2 Policy and Procedure

a. All USAREC personnel will adhere to prescribed enlistment processing standards in order to eliminate recruiter misconduct (RM) that can lead to defective, erroneous or fraudulent enlistments.

b. Report all allegations of RM IAW chapter 7-4.2. Processing procedure reviews (PPRs) will be conducted IAW chapter 7-2.1.

c. Allegations of RM may also be reported directly to RSD HOTLINE1-800-223-3735, extension 63001, or usarmy.knox.usarec.mbx.hq-rsd-improprieties@mail.mil.

d. USAREC Soldiers that commit an instance of RM as defined by chapter 7-3 may be subject to disciplinary or administrative action such as involuntary reassignment, separation, suspension or removal from recruiting duties, termination of Special Duty Assignment Pay (SDAP), and withdrawal of the Recruiting Military Occupational Specialty (MOS) code. DACs who commit RMs may be subject to appropriate administrative actions as provided by Office of Personnel Management (OPM) regulations.

7-1.3 Additional Responsibilities

a. Director, RSD will:

- (1) Provide oversight of the RSP and procedures.
- (2) Provide oversight for the CG and DCG-O by validating subordinate units are enforcing and training the RSP through inspections.
- (3) Develop and update information requirements and business practices that monitor the enlistment process for compliance with applicable policies and regulations.
- (4) Coordinate with USAREC IG and Bde Recruiting Standards Teams (RST) to inspect the Bn's RSP as part of the Organization Inspection Program (OIP).
- (5) Ensure RM allegations are investigated and reported to DA-G1 and Office of the Secretary of Defense (OSD) IAW DoD Instruction 1304.32, Enclosure 6, dated 06 March 2013 and Information Memo dated 19 August 2016.
- (6) Provide training support to subordinate elements of the command on the RSP.
- (7) Coordinate between USAREC and the US Army Criminal Investigation Command (USACIDC) for reports of investigation (ROI), if applicable.
- (8) Analyze PPRs and RMs for systemic enlistment errors, trends and root causes and brief the command as required.
- (9) Review ROI per current CG withhold policy for administrative and investigative thoroughness.

b. SJA/Brigade Judge Advocate (BJA) will:

- (1) Assist BJAs and civilian attorneys with PPRs, RM investigations, and other legal actions.
- (2) Provide legal advice to USAREC and subordinate Cdrs on RMs.
- (3) Process substantiated RM cases to the CG which fall under misconduct or action IAW the CG withhold policy.

c. Bde Cdrs will:

- (1) Ensure the inspection of subordinate unit's RSP.
- (2) Conduct (with a minimum frequency of quarterly) Volume II analysis and reporting down to the company level. Communicate trends of the Volume II analysis reporting to the appropriate Cdrs. Maintain Volume II analysis and reporting for the current and previous FY.
- (3) Validate RSP and Investigating Officer (IO) training at Bn.
- (4) Provide a watchful and responsible care of all PPRs and RM investigations.
 - (a) PPR: Review all subordinate Bn PPR Logs (UF 601-210.30) monthly to ensure subordinate commanders are conducting all required PPRs IAW Chapter 7-2.2 and identifying trends and correcting areas identified as a possible training deficiency.
 - (b) RM: Review and sign all UF 601-210.32 on completed substantiated RM investigations to ensure completeness and accuracy. May delegate review process of completed not substantiated RM investigations to the Bde XO. Report results to RSD for tracking.
 - (c) RM: Review case processing efficiency and take appropriate action on all cases over 60 days.
 - (d) RM: Review all subordinate Bn RM Logs (UF601-210.31) to ensure they are complete and accurate.
 - (e) RM: Review monthly trends in areas of RMs and direct training in specific areas identified as a possible training deficiency.
- (5) Monitor processing by BJAs to ensure a timely legal review of all RMs.

d. Bn Cdrs will:

- (1) Execute and train subordinates on the RSP IAW regulation and applicable policies. Maintain training records on file for the current and previous FY.
- (2) Conduct (with a minimum frequency of monthly) Volume II analysis and reporting down to station level. Update Company Cdrs and Bn Ops on any trends and ensure appropriate action is taken for negative trends. Maintain Volume II analysis and reporting for the current and previous FY.
- (3) Ensure XOs, or designated unit representatives, are trained on the RSP, Volume II analysis and reporting, and enlistment QC processes. Maintain training records on file for the current and previous FY.
- (4) Train all officers and NCOs in the grade/position of E8 and above, DACs permanently assigned to an Operations and/or MEPS positions graded as GS-07 through GS-09 on IO procedures. Maintain training records on file for the current and previous FY.
- (5) Brief all newly assigned personnel on the RSP. Maintain training records on file for the current and previous FY.
- (6) Maintain records, reports and training pertaining to the RSP inspections for the current and previous FY.
- (7) Provide watchful and responsible care of all PPRs and RM investigations.
 - (a) PPR: Ensure XOs, or designated unit representative (see 7-2.4a) appoint, by UF 601-210.35 (Notification of Processing Procedure Review and Determination) appropriate unit members to conduct reviews.

- (b) PPR: Ensure all PPRs are completed within 15 calendar days.
- (c) PPR: Review processing efficiency and take appropriate action on all reviews over 15 days.
- (d) PPR: Ensure all required reviews are being conducted.
- (e) PPR: Evaluate and close each PPR to determine whether an RM investigation is necessary and what, if any, immediate action is required for the enlistment (for example, FS separation, renegotiation, notify a TPU, etc.). At no time will this evaluation be delegated to subordinate officers or NCOs.
- (f) PPR: Review trends monthly and direct training in specific areas identified as a possible training deficiency.
- (g) PPR: Maintain all PPR; UF 601-210.35 on file for the current and previous FY.
- (h) RM: Will appoint, or a principle staff officer (in the grade of Major or above) will appoint, an Investigating Officer (IO) to conduct RM Investigations. This appointment will be an official MFR.
- (i) RM: Ensure all ROI are completed within 60 calendar days. Review case processing efficiency and take appropriate action on all ROIs over 60 days.
- (j) RM: Review all PPRs and RM allegations for administrative and investigative thoroughness, and completeness.
- (k) RM: Maintain RM log (UF 601-210.31) for the current and previous FY.
- (1) Properly address instances of misconduct during the recruiting process.
- (2) Forward unit monthly PPR Logs (UF 601-210.30) and RM Logs (UF601-210.31) to Bde RST or designated representative.

7-1.4 Delegations of Authority

- a. The Bde Cdr(s) or acting Bde Cdr, and Bn Cdr(s) or acting Bn Cdr (in the grade of major or above) may temporarily suspend personnel from recruiting duty status.
- b. Delegation of authority does not relieve Cdrs or persons to whom authority is delegated of their responsibilities under this regulation.

7-2. Processing Procedure Review (PPR)

7-2.1 Purpose

Review suspect or questionable facts and circumstances in the recruiting process, without allegation of a RM, to determine if an RM investigation is warranted. The PPR is initiated on a UF 601-210.35. The PPR reviews circumstances and facts, results of the inquiry, and recommendation on the UF 601-210.35. The Bn Cdr reviews the inquiry to determine if evidence reveals that an RM allegation is present. If credible evidence is found, or during the inquiry an allegation is made, the Bn Cdr initiates an RM investigation. If no allegation is revealed or evidence is revealed, the PPR is closed with no RM investigation required on the UF 601-210.35.

7-2.2 PPR (Misconduct Review) Defined

a. PPRs are to review discrepancies or circumstances that indicate a possible RM. The PPR will be conducted on the UF 601-210.35. The PPR will determine if the act or omission was done with the intent, and purpose, to wrongfully facilitate the recruiting process. The following are mandatory PPRs;

- (1) Discrepancies that made the applicant/FS disqualified for further processing (temporary or permanent) between existing information on the Medical Prescreen of Medical History Report (DD 2807-2), and the Report of Medical History (DD 2807-1), Supplemental Health Screening Questionnaire (UMF Form 40-1-15-1-E), or SF 86. Additionally, discrepancies listed on the DD Form 2808 will be used to initiate a PPR when the discrepancy indicates a possible RM. Any undisclosed incidents, or suspected incidents of self-harm, self-mutilation, self-cutting, or self-injury will require a PPR to be conducted on the UF 601-210.35.
- (2) All increases of 20 or more points on an ASVAB retest to include confirmation test failure.
- (3) FS loss or a physical only applicant with positive drug and alcohol test results.
- (4) All separations of enlistees reflected on the Training Base Attrition Report, Appendix H, Volume II analysis and reporting with a Separation Program Designator (SPD) code of:
 - (a) JFM, JFX, or KFN; possible violation related to concealed medical information.
 - (b) JDG; possible violation related to concealed dependents.
 - (c) JFC, JDA; possible violation related to fraudulent or erroneous enlistment or accession.
 - (d) JFB; possible violation related to improper or false parental consent.
- (5) All enlistees reflected on the Prior Service List, Appendix F, and Volume II with unreported/undisclosed PS. This is a possible violation of concealed prior military service.
- (6) FS loss for fraudulent enlistment or accession (except for individuals identified as a match) is a possible violation of concealed medical, conduct or administrative information. Individuals identified as a match (RA and

AR) will follow the procedures in appendix G.

b. Do not conduct a PPR when credible irrefutable documentary evidence exists. Conduct an RM investigation.

c. All PPRs are reported to the Bn XO, or designated unit representative, as soon as possible, but not later than one (1) working day from discovery.

d. For a PPR, the case number will consist of the four digit Recruiting Station Identification (RSID) followed by the last number of the Fiscal Year (FY), and end with the two digit case number (start with 01). For example; if the first PPR for FY 15 in the Cleveland Bn occurs in the Cuyahoga Falls Station, Medina Company, the first PPR number would be (5C1J/501). Maintain a UF 601-210.30 (Processing Procedure Review Log), see Figure 2.

7-2.3 PPR (Administrative Review) Defined

An error within the DEP/DTP-In process that may have violated current USAREC Messages, policies or procedures. Errors (not listed in chapter 7-3.2) that are discovered and corrected during the DEP +10 or the Before Ship quality control (QC) procedures require a PPR on UF 601-210.35. The PPR will determine if the act or omission was done intentionally to wrongfully facilitate the recruiting process. DEP/DTP-in errors discovered on, or after the original scheduled ship day, will be considered an RM.

a. Failure to report and/or investigate known, or suspected RMs.

b. Failure to upload required source documents (including sex offender checks, live scan, or police check results).

c. Processing prior to LS.

d. MOS qualifications and time in DEP/DTP requirements; processing resulting in a training reservation for an MOS which the applicant does not have all necessary qualifications. This includes but is not limited to, driver's license requirement, driver's license expiration, education requirements, physical requirements or drug use.

e. Failure to identify information that disqualifies an applicant (temporary or permanent) for enlistment, accession, bonuses, incentives, training seat, option, MOS, education benefits, promotion, or entry in the DEP/DTP/DS.

7-2.4 Responsibility for Appointing PPR Official

a. The Bn XO has primary staff responsibility for oversight of PPRs at the Bn level and should normally be the appointing authority; however, any office with authority to appoint a preliminary inquiry, to include the Bn Ops SGM, may appoint a PPR. Any appointing PPR official may authorize, through verbal or email confirmation, an authorization individual to conduct a PPR prior to initiating the UF 601-210.34. Verbal authorization must be given individually, "blanket orders" are not authorized.

b. Personnel who may be appointed to conduct a PPR: Commissioned officers, NCOs in the rank of MSG and above, NCOs in the rank of SFC assigned as the SGC or in an E-8 position, DACs permanently assigned to a position graded as GS-07 or above, DAC investigators assigned to RSD, and SFC and above assigned to RSD (UF 601-210.35).

7-2.5 PPR Responsibilities

a. Individuals conducting the PPR must understand requirements of the review.

b. Review circumstantial and/or documentary evidence.

c. Review required regulations, policy, and messages.

d. Determine personnel to interview if necessary. Interviews should include all available fact witnesses and other persons who may assist in determining whether a PPR should become a RM investigation.

e. Conduct interviews either face-to-face or telephonically, if necessary. However, other reliable means of communication, including email, may be employed when face-to-face or telephonic communication is impractical.

f. Complete UF 601-210.35 to the appointing authority detailing results of review. The UF 601-210.35 will identify the personnel interviewed and applicable enlistment or commissioning documents used.

g. Conversation records, statements, emails, or other correspondence are not required unless they are necessary to clarify the report.

h. Complete PPR within 15 calendar days with one of the below recommendations:

(1) Close PPR with no further action; no credible evidence or allegation was discovered to warrant further inquiry or investigation.

(2) Close PPR (Misconduct Review or Administrative Review) with corrective action and / or training. (Note: This option will not be used when there is an allegation IAW UR 601-210, Chapter 7-3.2 of concealment, falsification, testing irregularity, false-promises, or coercion)

(3) Close PPR and initiate an RM based on the allegation received or credible evidence obtained that indicate the recruiter knowingly directed the fabrication, withheld or altered applicant or enlistment information, advised an

applicant not to disclose pertinent information. Includes withholding medical information, knowingly utilized false diplomas, intentionally provided false information, or intentionally concealed information necessary to determine the eligibility, qualification, military entitlements, or certification of an applicant to enlist (or enlist for a specialty, grade, or rating) for which the applicant is not eligible.

i. Battalion Commander will evaluate and close each PPR to determine whether an RM investigation is necessary. At no time will this evaluation be delegated to subordinate officers or NCOs.

7-2.6 Suspension of Favorable Personnel Actions (Flag) and Article 31 Rights Warning

USAREC personnel are not normally flagged during a PPR. Officials' sworn statements are not normally required. Article 31 rights warnings are required as soon as personnel conducting a review or investigation suspect misconduct (for questions about Article 31 rights warnings, consult with the BJA prior to conducting any questioning). Once an individual conducting a PPR suspects any recruiting personnel of misconduct they must cease questioning until Art. 31 rights warnings are read to the individual. Additionally, once an Inquiry Official suspects any recruiting personnel of misconduct, they must immediately inform the chain of command to allow their determination of whether to flag the Soldier IAW AR 600-8-2.

7-3. Recruiter Misconduct (RM)

7-3.1 Purpose

Cdrs are required to thoroughly investigate allegations of an RM and when substantiated, initiated appropriate training or other appropriate action. For the purpose of this chapter, the term recruiter is used to refer to all military, civilian, or contracted personnel whether attached, detailed, assigned, or involved in the recruiting process. A RM is a reportable misconduct.

7-3.2 Recruiter Misconduct Defined

a. Those intentional acts or intentional omissions listed in paragraph d. below that are perpetrated by a recruiter to facilitate the recruiting process for an applicant. It includes any act or omission which did intentionally cause to enlist or is designed to enlist an individual not qualified for Army enlistment or any act or omission which did intentionally provide, or is designed to provide an Army bonus, benefit, option, or MOS to an individual not qualified for that bonus, benefit, option, or MOS. Incidents are reported based on the date of the allegation regardless of when the possible infraction or final disposition occurred. Each recruiter involved in an allegation is reported as a separate allegation. Multiple allegations against one recruiter, with one applicant, reported at the same time, are reported as one allegation. If more than one applicant is involved, then each allegation is counted as a separate allegation for reporting purposes. This paragraph is punitive. Individuals who violate this policy may be subject to punishment under the UCMJ. Commanders must seek the advice and counsel of their legal advisor when taking actions pursuant to this paragraph.

b. Facilitate the recruiting processes: An intentional action or intentional event to qualify a prospect, applicant, or DEP/ DTP member for accession into another Army component, such as AR or RA Service when it is required under AR 601-210 or related DoD, DA, or USAREC regulation, issuance, or policy.

c. Omission: The failure to do what is required by law or legal authority.

d. Recruiter Misconduct

(1) Concealment. Knowingly directing the fabrication, withholding, altering or concealing applicant information. Advising an applicant not to disclose pertinent information. Includes withholding medical information, knowingly utilizing false diplomas, purposely providing false information, or intentionally concealing information necessary to determine the eligibility, qualification, military entitlements, or certification of an applicant to enlist (or enlist for a specialty, grade or rating) for which the applicant is not eligible.

(a) Concealed medical information and recruiter assistance. This RM occurs when there is an allegation that recruiting personnel knowingly either omitted medical information, omitted details of a medical condition from the enlistment record, or advised or assisted an applicant to take any medication or supplement to become medically qualified.

1. Recruiters will not conceal, assist in the concealment of, or advise an applicant to conceal any medical information, whether or not disqualifying.

2. Recruiters will not give, or advise applicants to use, any pharmaceutical product, medicine, medication, or remedy, whether controlled, prescribed, or sold over the counter, for the purpose of meeting enlistment or commissioning eligibility.

(b) Concealed Police Record. This RM is initiated when there is an allegation recruiting personnel either omitted law violations, or omitted detail of law violations from the enlistment record.

1. Recruiters will not intentionally interfere with, or participate, in the civilian criminal or civil process on behalf of a prospect or applicant of their own volition. Recruiters will not knowingly allow persons who have an unpaid fine or are pending charges (including unfiled charges) to process or enter the DEP/DTP/DS until all such restrictions are removed. Recruiters will not allow individuals who are confined in any criminal justice facility, on probation, parole, or similar status to process or enter the DEP/DTP/DS until all such restrictions are removed. Recruiters are prohibited from participating in the release of individuals from such restrictions whether by paying fines, appearing in court with applicants, testifying for applicants, or interceding on behalf of these individuals in any manner.

2. Applicants must disclose all prior and pending law violations, whether civilian or military. Recruiters will not conceal, assist in the concealment, or advise an applicant to conceal any information.

(c) Concealed dependents. Recruiters will not conceal, assist in the concealment of, or advise an applicant to conceal the existence of a dependent(s) as defined by AR 601-210.

1. Recruiters will not recommend, encourage, or materially assist any person in the transfer of custody of their minor children for the purpose of meeting eligibility requirements. Informing applicants that they may apply for or be permitted to regain custody of their children during their first enlistment or TOS is also prohibited. This policy does not prevent recruiters from informing such applicants of the basis for the Army's policy and explaining eligibility requirements IAW AR 601-210.

2. Recruiters will not provide an applicant with sample custody agreements or templates, or assist an applicant in filling out custody paperwork.

(d) Concealed Prior Service. Recruiters will not conceal or assist in the concealment of an applicant's PS and/or the concealment of applicants who are considered Glossary Non-Prior Service (GNPS-applicants with 179 days or less, to include zero days of AD, in any component of the Armed Forces). Recruiters will not access an applicant into the AR for the purpose of qualifying that person for accession into the RA as PS or GNPS (this does not include AMEDD MAVNI applicants).

(2) Falsification of Documents. Recruiters will not intentionally falsify, assist in falsifying, knowingly use any false documents, information, or intentionally omit any material information pertaining to an applicant's qualification for enlistment, officer accession, option, bonus, benefit, or referral credit for promotion. This prohibition includes any physical or electronic records or entries made or used during enlistment, and/or officer accession processing. This includes the use of any documents bearing forged or unauthorized signatures to include the copy/paste of any written or digital signatures with or without consent.

(a) Recruiters will not possess any blank documents which could be used to determine eligibility of an applicant (e.g. source documents).

(b) Recruiters will not pre-sign, nor have the applicant pre-sign, any forms.

(c) Recruiters will not sign on behalf of any DA personnel, or any official capacity which they do not have authority, who are required to sign an enlistment or officer accession document unless permission was expressly granted, and the document clearly indicated that the recruiter signed in a representative capacity.

(3) Cheating on Tests. Recruiting personnel may not use ASVAB tests, locally developed test questions, test aids, or commercial study guides to familiarize applicants or potential applicant with the ASVAB. Applicants may be advised that commercial study guides are available; however, commercial study guides will not be maintained, or in the possession of recruiting personnel for use by applicants. Recruiting personnel will not participate in applicant study preparation, nor provide or recommend actions that would afford an applicant with an unfair advantage towards improving ASVAB scores. The use of ringers or imposters are also prohibited

(4) False Promise. The act of knowingly misrepresenting benefits, enlistments, or other aspects of service. Recruiters will not knowingly mislead or misinform a prospect or applicant regarding any aspect of processing, entitlements, benefits, or other aspects of the Army to entice a prospect or applicant to access or enlist into either the RA or AR. This includes "conditional" enlistments in which an applicant enlists based on a recruiter's assurance that the applicant's prospects for selection for another program will improve. Other examples include, but are not limited to, false promises of cash bonus, Student Loan Repayment Program (SLRP), regaining custody of dependent children prior to completion of the first term of enlistment, overseas assignments, or a specific station of choice, etc.

(5) Coercion. Recruiters will not threaten, coerce, or intimidate any person for the purpose of enlisting into the FS (DEP/DTP) Program or inducing a FS to report to AD. This includes misrepresenting the likelihood of being apprehended and/or ordered to AD. It also includes obstructing a FS from being separated from the DEP/DTP. Although recruiters may properly attempt to "resell" a FS, they will not unreasonably delay the process of a FS's request for separation.

(a) Recruiters will not induce, attempt to induce, or assist a FS to fail to report to AD or IADT after taking the Oath of Enlistment or Oath of Office and/or receiving orders to AD or IADT.

(b) Tampering with a witness or interfering with the investigation of an RM allegation.

7-3.3 Responsibility for Appointing Investigating Officers (IO)

a. Bn Cdrs will appoint, or a principle staff officer (in the grade of Major or above) will appoint, an Investigating Officer (IO) to conduct RM investigations. This appointment will be an official MFR.

b. Personnel who may be appointed to conduct the RM investigation: commissioned officers and DACs permanently assigned to a position graded as GS-11 or above. (RM-Appointment of IO Memo.)

(1) Those persons who, in the opinion of the appointing authority, are best qualified for the duty by reason of their education, training, experience, length of service, demonstrated sound judgement and temperament. IOs must be impartial, unbiased, objective, and have the ability to complete the investigation in a timely manner. If an appointing authority determines that a person with the required experience and expertise is not available within his or her organization, he or she may request assistance from a superior in his or her chain of command or supervision, or coordinate with a counterpart to obtain an IO with the required education, training, experience, and expertise to conduct the investigation.

(2) Only commissioned officers, warrant officers, and DACs permanently assigned to a position graded as GS-11 or above may be appointed as IOs. The CG may approve noncommissioned officers in the grade E-7 or above may be appointed as IOs when the appointing authority determines that military exigencies exist and no commissioned officers, warrant officers or qualified DACs are readily available.

c. Personnel who may be appointed as an assistant to the RM investigation: Commissioned officers, NCOs in the rank of MSG and above, DACs permanently assigned to a position graded as GS-11 or above, DAC investigators assigned to RSD, and SFC and above assigned to RSD.

7-4. Processing and Investigation of RMs

7-4.1 Purpose

This chapter prescribes the procedures for reporting, processing, investigating, and disposing of RM allegations (see flowchart at Figure 2). Deviations from these procedures may be made only with the approval of the Bde Cdr after consultation with USAREC RSD and the SJA/BJA. ROI are exempt from information requirements IAW AR 335-15 (Management Information Control System).

7-4.2 Allegation Reporting Requirements

a. Report all completed RM investigations to USAREC RSD immediately upon completion. RSD will report all RMs to DAG1 and OSD as required.

b. Allegations may come from any source and can be either verbal or written alleging that any USAREC personnel committed an RM. Track all alleged and reported RMs using UF 601-210.31 (Recruiting Misconduct Investigation Log).

c. RM allegations must be reported to the BN XO within (1) working day of discovery. The Bn will have one working day to report to RSD using UF 601-210.34 via email following the reporting format at Figure 2.

d. RM allegations identified by HQ USAREC personnel, or any external source must be reported to USAREC RSD within three (3) working days from identification. RSD will notify the respective Bn using UF 601-210.34 via email following the reporting format at Figure 2.

e. Reception Battalion (RECBN) liaisons must report RM allegations within (3) working days via UF 601-210.33 (Report of Alleged or Suspected Recruiting Misconduct) to USAREC RSD, via e-mail to usarmy.knox.usarec.mbx.hq-rsdirregularities@mail.mil. (UF 601-210.33)

f. Cdrs must evaluate each alleged RM to determine whether any immediate action must be taken regarding the applicant or enlistee involved and take action as necessary if required

7-4.3 Processing RM Investigations (Figure 2):

Review the allegation and any supporting documentation to determine whether all necessary pre-investigative information has been provided. After an RM case number has been received, it is the Bn Cdr's discretion to determine the necessary course of action to take with the RM allegation and ensure all ROIs are completed in a timely manner where combined ROI processing time with BJA does not exceed 60 calendar days.

a. Conduct a Preliminary Inquiry (Commander's inquiry), Administrative Investigation or through appointment of a Board of Officers IAW 15-6 is likely impractical under normal circumstances. (AR 15-6 and/or USAREC Pamphlet UP 27-2New.)

(1) Preliminary Inquiry: A preliminary inquiry IAW AR 15-6, chapter 4 is an informal investigation. The purposes of a preliminary inquiry include, but are not limited to, ascertaining the magnitude of a problem; identifying and interviewing witnesses and summarizing and recording their statements; and determining whether a more extensive investigation is warranted, and if warranted, assisting in determining the scope of such investigation.

A preliminary inquiry under AR 15-6 may satisfy the preliminary inquiry requirement, sometimes referred to as "Commander's Inquiry," in RCM 303, MCM.

(2) Administrative Investigation: Investigation procedures are used by a single IO, or by an investigation team consisting of an IO and one or more assistant IOs designated by the appointing authority to assist the IO in questioning witnesses, taking sworn statements, and otherwise facilitating evidence gathering. In the event that assistant IOs are used, those designated as assistants must abide by the provisions of AR 15-6, chapter 3. There is no recorder. The IO prescribes the duties of each assistant IO and determines the findings and recommendations.

(3) Board of Officers: An administrative fact-finding procedure using a board of investigating officers. The subject matter under investigation determines the procedural rule to follow IAW AR 15-6.

b. Review the IO's recommendation.

c. Include recommendations for disposition regarding the case in the Cdr's endorsement on the UF 601-210.32 (Notification and Recruiter Misconduct Allegation and Determination). Possible recommendations for substantiated RMs are listed below, though this list is not all inclusive:

- (1) No action taken
- (2) Other/Training
- (3) Adverse administrative action
- (4) Non-judicial Punishment/Article 15
- (5) Removal from recruiting
- (6) Initiate separation proceedings
- (7) Courts Martial

d. Close the case as appropriate, except where the CG, USAREC has retained authority or where recommended final action is beyond the scope of the Bn Cdr's authority in Bn/Bde Cdr remarks on UF 601-210.32.

e. Ensure Part V of the UF 601-210.32 is completed by the Soldier/DAC.

f. All completed RM investigations are forwarded to RSD for review and filing.

g. Forward cases IAW CG withhold policy, to the RSD Director who will review and forward to SJA for review.

h. Consider if suspension from recruiting duty is warranted, taking into account the severity of the RM allegations the number of substantiated RMs the Soldier has against them, and the apparent strength of evidence of the alleged RM. Termination of SDAP is effective on the date of suspension.

i. Notify suspended recruiters in writing; provide them with a copy of the supporting documentation, and their right to appeal the decision. Suspension is directed using an MFR format. Suspended recruiters must not perform recruiting duties IAW AR 601-1 (Assignment of Enlisted Personnel to the US Army Recruiting Command) chapter 5-7. Soldiers assigned to duty at any location outside their local travel area must be placed on TDY orders prior to reassignment.

j. Notify Soldier after decision indicating a final action unless authority is withheld or action is pending at HQ USAREC.

k. Refer substantiated cases to the appropriate recruiting personnel for acknowledgment on UF 601-210.32 and appeal in an MFR. The Soldier or Civilian is given a copy of the investigation. They have ten (10) calendar days to review the file and submit appeal matters from the date notified; extensions may be granted.

l. Forward submitted appeals to the Bde Cdr for consideration.

m. All appeals will be included in the investigation when forwarded to USAREC RSD

7-4.4 Investigating and Inquiry Officer Responsibilities

a. See AR 15-6 (Procedures for Investigating Officers and Boards of Officers).

b. During Administrative Investigation into RM allegation, the IO will take face-to-face sworn statements from all witnesses using DA 2823 (Sworn Statement Form). Explain, in detail, the circumstances if the IO is unable to obtain face-to-face sworn statements. All statements must be written legibly or typed. IOs should contact RSD if they are having trouble locating witnesses for assistance.

c. The IO will use the following definitions in making determination of substantiated or not substantiated RM allegation:

(1) Preponderance of Evidence. A proposed finding is substantiated if it is supported by a greater weight of the evidence than supports a contrary conclusion. Proving an allegation is done by judging the weight, credibility, and value of evidence. If an allegation is not supported by greater evidence, then it is not substantiated. Not substantiated is not equivalent to "innocent" or "guiltless," but only that the evidence did not substantiate the allegation.

(2) Substantiated. An action or omission done deliberately with the intent to wrongfully enlist an unqualified individual, improperly provide a benefit to an individual, or commit specific misconduct prohibited by this regulation. The intent must be supported by evidence indicating that the omission or act was deliberate, rather than evidence indicating the act was negligent. Proving intent is done through judging the weight, credibility, and value

of evidence. If intent is supported by greater evidence, then the allegation is substantiated.

(3) Root Cause Analysis. The following root cause analysis will be utilized by the IO to address their assessment of whether alleged RM allegation is intentional in the ROI.

(a) Don't know-if recruiters did not know the standard. This will not apply if, by position (Station Commander, Guidance Counselor, First Sergeant, etc.) had an obligation to know when exercising due-diligence in the performance of their duties. The IO must clearly articulate why the recruiter did not know the requirements or proper procedures; or

(b) Can't Comply-If recruiters are prevented from complying, their failure to comply with the standard is normally not misconduct. The IO must clearly articulate what obstacles or directives prevented the recruiter from complying; or

(c) Won't Comply – If a recruiter knows the standard but won't comply, this is normally considered intentional misconduct. The IO must clearly articulate the facts and circumstances that prove the recruiter knew the requirements and could comply with the proper procedures, but elected on their own volition not to comply with established regulations or policies.

7-4.5 Suspension of favorable personnel actions (Flag)

a. A Bn Cdr must immediately flag Soldiers under RM investigation IAW AR 600-8-2 (Suspension of Favorable Personnel Actions) chapter 2-2.

b. The Bn Cdr must ensure every Soldier that receives investigation notification during an on-going RM investigation or notification of conclusion of an RM with adverse action not yet completed is flagged. There is no requirement to suspend a recruiter who receives a notification.

c. The Soldier's current Bn Cdr must flag them when notified by the Soldier's previous unit of an ongoing RM investigation, that an RM must be initiated by the previous unit or if final action for a completed RM investigation is pending.

d. A Bn Cdr must remove a flag within three (3) days of notification of final action and completion of all personnel actions required.

7-4.6 Request for investigation by USACIDC

a. Alleged and suspected RMs are normally investigated by USAREC in authority with the Memorandum of Understanding (MOU) between USAREC and US Army Criminal Investigation Division (USACIDC). USAREC RSD, is responsible for ensuring all reports of misconduct within CID's investigative jurisdiction are properly reported to the CID liaison officer.

b. When an offense listed in AR 195-2 (Criminal Investigation Activities) appendix B, is linked to an alleged or suspected RM, CID investigative assistance is requested by the appointing authority. Offenses detected by the IO during the course of the investigation are reported to the appointing authority, which will coordinate with RSD and the servicing CID office. The IO will continue with their investigation and will not delay the report to the appointing authority pending the conclusion of the CID investigation.

c. Bn Cdrs will monitor the progress of the CID investigation and maintain close liaison with the agent-in-charge. Ask the agent to furnish statements of witnesses and other relevant evidence as they are obtained. The conclusions expressed by the CID agent in his or her final ROI are not binding on Cdrs. Cdrs have the authority to initiate UCMJ or adverse personnel actions against the subjects of a CID investigation as they determine. For this reason, Cdrs who obtain sufficient evidence from CID, in advance of the completion of the final law enforcement report, can proceed to dispose of the matter being investigated. Issues with CID investigations are addressed through the BJA or SJA.

7-4.7 HQ USAREC, RSD Review

a. RSD is responsible for the review of all RM's where the FS reported to Initial Active Duty for Training (IADT).

b. Recruiter misconduct investigations requiring SJA review will be based on current CG withhold policy. When required, the Director of RSD will forward the investigation results, with the CDR recommendation, to the SJA who will prepare the case for CG review and action.

c. Subordinate Commander's findings conflict with applicable legal authority or clear and convincing factual evidence. When required, the Director of RSD will forward the investigation results to the SJA who will review the RM under a clear and convincing factual evidence standard. The case will then be adjudicated by the DCG IAW current CG memorandum; Delegation of Authority to Close Recruiter Misconduct Investigations.

7-4.8 Final Disposition of Cases Reviewed by Commanding General

a. The OSJA provides RSD a copy of the CG's decision and any disciplinary or administrative action taken by the CG for final investigations. The SJA prepares the appropriate legal documents for cases reviewed by the CG. In cases referred to CID, the OSJA assists CID on titling decisions.

b. RSD will notify CID, as required, for titling Soldier(s) in a CID ROI. Upon receipt, of titling correspondence, RSD must notify the chain of command. When a Soldier is relieved from recruiting duties for a substantiated RM, appropriate action is taken by the Assistant Chief of Staff G1 to withdraw the recruiter MOS Code 79R or additional skill identifier and all incentive recruiting awards and to verify that a relief for cause evaluation is entered into the person's official record.

7-5. Recruiting Brigade and Bn Management Reporting System

7-5.1 Purpose

The Recruiting Standards Functional Area Analysis and Data Package, Volume II, Rctg Bde/Bn Management Reporting System, provides Cdrs and recruiting supervisors of the Bde and Bn with data in RSP functional areas. This data provides a method for evaluating the performance of stations, companies, and battalions, as it relates to production. The data serves to identify negative or positive trends or potential PPRs. Report executors identify units that deviated from the standard and conduct analysis to determine the possible causes for deviation. Units can retrieve data, conduct analysis, continue monitoring, and correct recruiting operation issues with monthly/quarterly sustainment training. The report assists the commander in maintaining the highest levels of integrity in recruiting.

Management Reporting System

a. Appendix B of the Volume II Report is used as the primary screening document in selected station functional areas down to company level. The numbers concerning attrition are a moving 12-month window. They provide information on FSTP losses, AR FS losses, training base attritions, possible PPRs, and 20-point ASVAB increases.

b. Appendix C of the Volume II Report, Army Recruiting Information Support System-Personnel (ARISS-PER) provides a listing of all recruiters and recruiting specialists assigned to the Bn. The unit should be familiar with reconciliation procedures to ensure the information listed for each recruiter is correct.

c. Appendix D of the Volume II Report, Erroneous Enlistment Report (EER), provides a listing of the cumulative recruiting calendar year information on those enlistees from the Bn with either an administrative or contractual error in their enlistment processing. The information is provided by the RECBN liaisons via UF 601- (Erroneous Enlistment Report).

d. Appendix F of the Volume II Report, Prior Service Versus Non-prior Service Report, provides a listing to identify whether an applicant being processed as a NPS has prior active military service.

e. Appendix G of the Volume II Report, the current FY RA FSTP separation listing identifies all cancelled FSTP enlistments.

f. Appendix H of the Volume II Report, current FY RA Training Base Attrition listing, provides a listing of RA individuals identified as a loss at training installations within the first 179 days of AD.

g. Appendix I of the Volume II Report, current FY AR Fail-to-Ship Report lists those enlistees in the AR that were separated prior to their ship date.

h. Appendix J of the Volume II Report, current FY Moral Waiver Report, identifies what types of conduct (moral) waivers are being approved for accessions from the Bn and whether the Soldiers are subsequently being discharged at training installations.

i. Appendix K of the Volume II Report, current FY Administrative and Medical Waiver Report identifies approved administrative and medical waivers and whether Soldiers are subsequently being discharged as Training Base Attrition.

j. Appendix L of the Volume II Report, is a moving 12-month window Recruiter's summary sheet. This data is similar to the unit matrix Appendix B as it provides information pertaining to the individual recruiter regarding the previous 12 months.

RECRUITER MISCONDUCT FLOW CHART

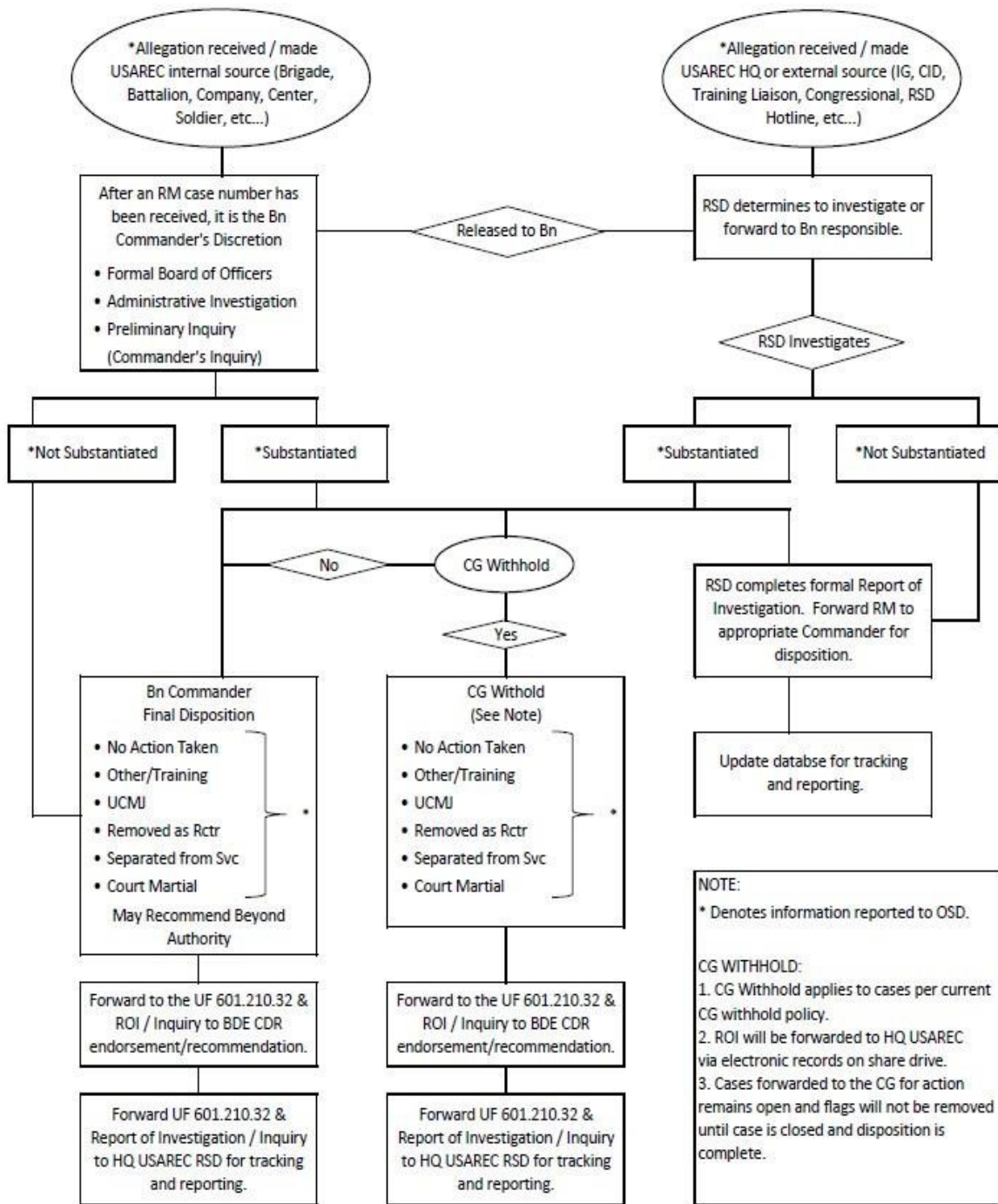

Figure 7-1. USAREC Recruiting Misconduct Flow Chart

Appendix A References

Section I Required Publications

AR 15-6

Procedures for Investigating Officers and Boards of Officers

AR 25-2

Information Assurance.

AR 25-55

The Department of the Army Freedom of Information Act Program.

AR 40-501

Standards of Medical Fitness.

AR 50-5

Nuclear Surety.

AR 135-7

Incentive Programs.

AR 135-178

Enlisted Administrative Separations.

AR 140-10

Assignments, Attachments, Details, and Transfers.

AR 195-2

Criminal Investigation Activities.

AR 335-15

Management Information Control System.

AR 600-8-2

Suspension of Favorable Personnel Actions.

AR 600-9

The Army Body Composition Program.

AR 600-20

Army Command Policy.

AR 601-25

Delay in porting for, and Exemption from Active Duty, Initial Active Duty Training, and Reserve Forces Duty.

AR 601-210

Active and Reserve Components Enlistment Program.

AR 614-200

Enlisted Assignments and Utilization Management.

AR 630-10

Absence without Leave, Desertion, and Administration of Personnel Involved in Civilian Court Proceedings.

AR 635-200

Active Duty Enlisted Administrative Separations.

DA Pam 611-21

Military Occupational Classification and Structure.

DOD 1312.1-I

Occupational Conversion Index (Enlisted/Officer/Civilian).

DODI 1304.32

Military Services Recruiting Related Reports.

DOD 5400.11-R

Department of Defense Privacy Program.

FM 6-22

Army Leadership.

UTC 5-03.2

Influencing and Interviewing

UR 350-13

School Recruiting Programs.

UR 601-2-1

Total Army Involvement in Recruiting (TAIR)

UR 350-1

Training and Leader Development.

UR 700-5

Integrated Logistics Support.

UP 385-10

Safety.

USMEPCOM Reg 40-8

Human Immunodeficiency Virus (HIV) and Department of Defense (DOD) Pre-accession Drug and Alcohol Testing (DAT) Program.

USMEPCOM Reg 715-4

Applicant Meals and Lodging Program.

USMEPCOM Reg 601-23

Personnel Procurement, Enlistment processing

This regulation provides policies and procedures on applicant processing; matters relating to preparing, maintaining, and distributing enlistment documents (including interviewing and fingerprinting enlistment applicants), processing Special Agreement Check (SAC) requests. It also provides instructions for implementation of MEPS functions required by the DoD, and GCs directives during peacetime and mobilization.

38 USC 30

All Volunteer Force Education Assistance Program.

Section II Related Publications

AR 140-111

U.S. Army Reserve Reenlistment Program.

AR 612-201

Initial Entry/Prior Service Trainee Support.

Section III Prescribed Forms

UF 601-210.02

Probation Officer and/or Court Records Report (Former UF 1037)

UF 601-210.04

Request for Information from Institution (Former FL 41)

UF 601-210.05

Guidance Counselor Shop Inspection Checklist (Former UF 1305)

UF 601-210.06

Erroneous Enlistment Report (Former FL 153)

UF 601-210.07

Match Log (Former UF 1054)

UF 601-210.08

Waiver Worksheet (Former UF 670)

UF 601-210.10

Security Clearance Questionnaire (Former UF 1227)

UF 601-210.11

Board Evaluation Sheet (Former UF 609)

UF 601-210.12

Packet Checklist Validation Form Letter (Former UFL 136)

UF 601-210.13

Loan Repayment Program In-Processing Counseling (Former UF 1232)

UF 601-210.14

Release of Arrest Information (Former UFL 146)

UF 601-210.15

Army Preprocessing Drug Screening Acknowledgment and Consent

UF 601-210.16

Army Recruiting Station Drug Screening/Test Log

UF 601-210.20

Future Soldier Hometown Shipping Program Checklist (Former UF 1302)

UF 601-210.21

Separation Request (Former UF 986)

UF 601-210.22

Request to Change Enlistment Option (Former UF 1035)

UF 601-210.23

The U.S. Army Recruiting Command Future Soldier Advanced Rank Verification (Former UF 1137)

UF 601-210.24

Future Soldier -Physical Training Program Statement (Former UF 992)

UF 601-210.26

Future Soldier Training Function Request and After Action Report (Former UF 1115)

UF 601-210.27

Medical Safety for Future Soldier Physical Training Program and Physical Fitness Assessments

UF 601-210.30

Processing Procedure Review Log (Former UF 737A)

UF 601-210.31

Recruiting Misconduct Investigation Log (Former UF 737)

UF 601-210.32

Notification of Recruiter Misconduct Allegation and Determination (Former UF 713)

UF 601-210.33

Report of Alleged Recruiting Misconduct (Former UF 315)

UF 601-210.34

Notification of Recruiter Misconduct (New form referenced in Chap. 7-4.2)

UF 601-210.35

Notification of Processing Procedure Review (New form referenced in Chap. 7-4)

UF 601-210.40

School Profile Evaluation (Former UF 1015)

UF 601-210.41

Education Evaluation Worksheet (Former UF 1015-A)

Section IV Referenced Forms

DA Form 61

Application for Appointment

DA Form 71

Oath of Office - Military Personnel

DA Form 2823

Sworn Statement Form

DA Form 3286

Statements for Enlistment, U.S. Army Enlistment Program, U.S. Army Delayed Enlistment Program

DA Form 3540

Certificate and Acknowledgment of U.S. Army Reserve Service Requirements and Methods of Fulfillment

DA Form 4187

Personnel Action

DA Form 5435-R

Statement of Understanding - The Selected Reserve Montgomery GI Bill

DD Form 4 series

Enlistment/Reenlistment Document - Armed Forces of the United States

DD Form 214

Certificate of Release or Discharge from Active Duty

DD Form 368

Request for Conditional Release

DD Form 369

Police Record Check

DD Form 370

Request for Reference

DD Form 1966 series

Record of Military Processing - Armed Forces of the United States

DD Form 2807-1

Report of Medical History

DD Form 2807-2

Medical Prescreen of Report of Medical History

DD Form 2808

Report of Medical Examination

DD Form 2983

Recruit/Trainee Prohibited Activities Acknowledgement

INS Form G-845

Document Verification Request

INS Form I-551

Alien Registration Receipt Card, NGB Form 22 Report of Separation and Record of Service

RPI 275 (old UF 1286)

PaYS Pocket Card

SF 86

Questionnaire for National Security Positions

SF 1199A

Direct Deposit Sign-Up Form

UF 350-1.2

Training Record

UMF 601-23-E

Report of Additional Information. (For use of this form see USMEPCOM Reg 601-23)

a. For processing procedures associated with Report of Additional Information see USMEPCOM Reg 601-23.

b. See chapter 7.3 for additional processing requirements when an applicant makes an RM allegation.

NOTE: The initial and final USMEPCOM 601-23-E is always uploaded in ERM.

UMF 680-3A-E

Request for Examination

UMF 727-E

Processing List (PL)

DD Form 2983

Recruit/trainee Prohibited Activities Acknowledgement

DD Form 785

Record of Dis-enrollment from Officer Candidate Type Training

Section V**User Guides**

These documents are referenced as recommended system process guides and are not incorporated as punitive regulatory guidance.

Recruiter Zone (RZ) User Guide (RZUG google link)

Leader Zone (LZ) WEBS 2018 Set-up Guide

Guidance Counselor Resource Center (GCRC) User Guide (GCRC UG-google link)

Live Scan User Guide (LSUG-google link)

Recruit Quota System (REQUEST) User Guide

MEPCOM Integrated Resource System (MIRS) User Guide

Appendix B

Recruit Quota System (REQUEST) Procedures

B-1. Purpose

Establish procedures for the efficient use of REQUEST for enlistments in the RA and AR.

B-2. General

REQUEST is an information management subsystem of KEYSTONE that provides the Army with an orderly and efficient mechanism for allocating training resources to new accessions.

- a. Any use of REQUEST and the information therein for a purpose or manner other than authorized is prohibited.
- b. Access to REQUEST is only granted to V7 Additional Skill Identifier (ASI) holders, when Bdes and Bns encounter a problem with the reservation process, contact the ROC through command channels.
- c. In the event of REQUEST failing, procedures for continuity of the reservation process are outlined in B-5.

B-3. Security

- a. REQUEST classification is sensitive according to the provisions of AR 25-2 (Information Assurance). The classified component includes all data files, the entire database, and all associated programming. At a minimum, all systems of records will be safeguarded IAW AR 25-55 (DA Freedom of Information Act (FOIA) Program).
- b. At no time will an individual log into REQUEST using another person's login ID and/or password.

B-4. REQUEST Use

- a. The following are abuses of the system and are prohibited for any enlistment.
 - (1) Duplicate reservation.
 - (2) Failure to cancel a reservation for an applicant that fails to process for enlistment at MEPS.
 - (3) Early ship or late ship reservations.
 - (4) Creating a reservation without the applicant present.
 - (5) Improper gender coding.
 - (6) Unqualified applicant reservations.
 - (7) Swapping. Enlisting an applicant under a reservation made for another applicant is not authorized.
 - (8) Uncommitted applicant reservation. A reservation made for an individual who does not execute an enlistment agreement immediately.
 - (9) Advanced reservation. In no case will a permanent reservation be made prior to the applicant's arrival at MEPS.
 - (10) Unsubstantiated reservation. A temporary or permanent reservation that contains data not substantiated by appropriate documentation.
 - (11) Securing a reservation with an incorrect education level and/or Armed Forces Qualification Test (AFQT) is considered fraudulent.
 - (12) MOS substitution. Changing an applicant's MOS to another MOS within the same career management field (CMF) is not authorized.
 - (13) GC SSN substitution.
 - (14) Recruiters making more than two temporary reservations for an applicant.
 - (15) Manipulating an ECLT/ALCPT score to qualify an applicant. An ECLT/ALCPT that has been passed with a 75 or higher will not require a retest. Intentionally advising an applicant to score lower on an ECLT/ALCPT because of a low ASVAB score is prohibited and will be turned over to RSD.
 - b. Authorized alternate REQUEST uses:
 - (1) A reservation for an RA applicant may be held until the next duty day, pending completion of enlistment processing only. GCs must cancel REQUEST reservations for applicants who have not completed enlistment processing by the day following the reservation.
- NOTE:** In no case will a permanent reservation (res hold) be held past the end of the phase line (PL).
- (2) An RA reservation can be held up to five (5) calendar days in the Far East (Japan and Korea) but not past the end of the Recruit Ship Month (RSM).
 - (3) Permanent reservations for AR applicants are not made and held over to the next working day under any circumstances.
 - (4) RA and AR temporary reservations may be held for seven (7) calendar days.

B-5. Alternate Procedures for Terminal or System Failure

a. In the event a REQUEST terminal becomes inoperable and no other terminal is immediately available, GCs contact their respective Bn Ops which have authorization to access the system and make the reservation. The HRC REQUEST office has established alternate commercial access directives. If a terminal failure is at the RECBN, liaisons call the ROC for system access and programs.

b. In the event of system failure, notify the Customer Support Branch (CSB), at 1-877-272-1330.

c. Notify the ROC, immediately of system failure(s) through command channels after notifying the Help Desk.

Appendix C Live Scan (LS)

C-1. Purpose

This appendix outlines policies and procedures for FBI background checks on applicants prior to processing at MEPS.

C-2. General

Recruiting personnel will not submit fingerprints (FPs) of applicants solely to ascertain if they are morally qualified for enlistment. Furthermore, recruiters will not FP themselves, family members (not processing for enlistment) or other recruiters. Do not fingerprint FSs pending shipment with the exception of processing errors resulting in an additional fingerprinting requirement.

C-3. Station Commanders and/or Recruiter Responsibilities

a. FP only those applicants who agree to enlist. Entry of the correct SSN for each applicant is essential. Enrollment and the results returning hinge on correct SSN data.

b. Complete all portions of the conduct screening pages in RZ prior to the submission of FPs. List all law violations of any level, to include traffic, with dispositions. The law violation(s) are considered as self-admitted offenses and will remain in RZ regardless of the LS results.

c. Applicants who agree to enlist must sign a completed DD 369. The signed DD 369 serves as authorization for capture. Upload the DD 369 in the applicant's ERM in the waiver folder labeled "Early Background Check (EBC) Release – DD369" prior to the submission of FPs.

d. Submit the FPs upon approval by the station commander or higher of the LS request. Enter the statement "Station Live Scan Authorized" into the applicant's contact history.

e. Utilize the Live Scan WEBS 2018 Set-up Guide for processing procedures.

f. Initiate a [UF 601-210.02\(s\) and/or](#) court dockets at all locations where charges are revealed or locations returned on the Record of Arrest and Prosecution (RAP) sheet (minor non-traffic or higher). Although UF 601-210.02(s)/court dockets are not required for traffic offenses (with the exception of careless/reckless driving), list all charges in RZ. The required UF 601-210.02s/court dockets are uploaded prior to transporting an applicant to MEPS for enlistment.

g. Capture all self-admitted charges and all charges that return from the LS results on the SF 86 along with the charge disposition.

h. Applicants will not be transported to a MEPS or lodging facility without LS results with the exception of applicants who are scheduled to ASVAB only. In the event the LS system is not operational, take instructions from EEPD via messages or OPS FLASH.

i. Results will typically be uploaded into ERM daily. Normal turnaround time for results are 24-48 hours after. If results are not in ERM or if they do not appear on the RMZ/Bi-Zone LS report 24 hours after the LS submission, the below information is in effect until further notice. (If results do not return to ERM, Select the appropriate RSID and enter the applicant's SSN. Select "Process". Access the LS report in My App by selecting "RMZ or BiZone", "Processing" and "Live Scan Report".) No HRC trouble ticket is required.

j. Send e-mail with screen shot of the Personal screen and the Transaction screen from the LS device to G3 NACLCLC at usarmy.knox.usarec.list.g3-nacclc-mgr@mail.mil (RMZ-Bi-Zone screen shot is not required). G3 NACLCLC will contact National Background Investigation Bureau (NBIB) to attempt to retrieve FP results telephonically. They will then return an email with results to upload into the EBC results folder as evidence of results.

k. If G3 NACLCLC reports there are no results available due to NBIB not receiving the submission, authorization will be given to G3 NACLCLC for applicant processing to continue using DD 369(s) and UF 601-210.02(s). Applicants who claim no law violation(s) will have DD 369(s) ran where they currently live, work, and or attend school (city, county and state). Applicants who admit to charge(s) above traffic level can process with DD 369(s)

where they currently live, work and or attend school (city, county and state).

NOTE: Live scan devices are not authorized for mobile use at this time and must remain secured inside the recruiting station at all times.

1. If G3 NACLIC confirms the LS results have a 'Record' or if an RMZ-Bi-Zone report shows 'Record' and there is no accompanying RAP Sheet a RAP Sheet must be ordered. Allow five (5) business days from the date of submission before requesting a RAP Sheet.

NOTE: Live Scan devices are not authorized for mobile use at this time and must remain secured inside the recruiting station at all times.

C-4. GC Responsibilities

- a. Ensure all charges that returned on the LS are listed on the SF 86 along with any previously revealed charges.
- b. Do not "No-Go" a projection if LS results are not present when conducting QC procedures.
- c. Do not enlist anyone into the DEP/DTP/DS without LS results.
- d. When the RMZ LS report is used, compare PRID from the LS report with the PRID of the applicant's record during the QC process.
- e. The LS process does not eliminate the FP submission during MEPS processing. Ensure all applicants who enlist are fingerprinted at the MEPS. The FP results from the MEPS submission are required to be uploaded in ERM under the Entrance National Agency Check (ENTNAC) RAP Sheet folder.

C-5. Validity Period/Retains

- a. LS results remain valid for 180 days. A new LS submission is needed outside of 180 days to enlist an applicant. If new violations are revealed prior to 180 days, no new LS is required. All new charges or violations are recorded IAW self-admission procedures. The required DD 369 and UF 601-210.02 are executed prior to enlisting the applicant.
- b. Retention in the DEP/DTP/DS is not authorized for applicants who initially return unclassifiable FP
- c. Results and discrepant charges after return of the MEPS submission results. DEP/DTP/DS discharge procedures for fraud will occur and a six (6) month wait is required to reprocess.

C-6. Live Scan for 6th BDE Overseas Locations (DEP Trips)

- a. Overseas applicants are not required to have LS results prior to enlisting into the DEP/DTP/DS. Capture FPs of applicants with a valid SSN during the trip and submit them. Capture and submit FPs for applicants who initially enlist with a TIN prior to receiving their SSN, upon issue of the SSN in either Honolulu or Guam.
- b. Applicants who enlist from Guam or Samoa who have a SSN require LS results prior to enlistment.
- c. Applicants from remote areas of Alaska who have no recruiter contact prior to arrival at MEPS, are exempt from LS submission prior to enlisting. GCs will ensure FP submission occurs during MEPS processing.

C-7. Assistance

Added note If an OPS FLASH is published directing a HRC Help Desk ticket for LS issues the below guidance will be used. If there is no current OPS FLASH directing this; C3 k above is the authoritative source.

Instructions to initiate a trouble ticket to the HRC Help Desk: usarmy.knox.hrc.mbx.it-help-desk@mail.mil for LS results that have not returned to ERM or disposition is not on the RMZ LS report:

- a. If after 48 hours no results have returned, stations will:
 - (1) Verify state indicated "transmitted ok".
 - (2) Verify SSN/SON/SOI/OPAC/ALC accuracy. Ensure the correct information is entered on the LS device particularly with the input of the OPAC/ALC code, SON and SOI codes. DA-EFP is the only entry acceptable for the OPAC/ALC code, the SON code is 676G and SOI code is A334. Any other codes will result in prints not being submitted successfully.
 - (3) If any of the above is not met, make corrections and resubmit.
 - (4) If (1) and (2) are met, do not resubmit FPs. The station will contact the HRC Help Desk to open a trouble ticket. Initiate a trouble ticket by sending an encrypted email screen shots of the LS device screen, the RMZ report and a screen shot of the actual DD 369 to usarmy.knox.hrc.mbx.it-help-desk@mail.mil. Once a ticket number is assigned and 24 hours has elapsed and there is not ticket resolution; processing can continue using DD 369(s) and UF 601-210.02(s). Applicants who claim no law violation(s) will have DD 369(s) ran where they currently live, work, and or attend school (city, county and state). Applicants who admit to charge(s) above traffic level can process with DD 369(s) where they currently live, work and or attend school (city, county and state).
- b. If applicants are able to be enrolled in FP submission due to poor quality of FPs, take a screenshot of the

enrollment screen proving the FPs were poor quality. Upload the screenshot in ERM under waivers, EBC results folder and process with DD 369(s)/UF 601-210.02(s) (take appropriate action for restrictions if fraudulent results return).

c. POC for technical issues/FP submission difficulties is the USAREC G6, IT Assistance Team at (502) 626-0066. Questions related to LS Policy can be addressed to EEPD at 1-800-688-9203, option 3. NOTE: If a station is having difficulty enrolling an applicant for a FP submission, they can refer to the G6 Knowledge Document_Livescan WEBS 2018 Set-up Guide at the following link: Click on “Samples and Certificates, then open the “USAREC Reg. 601-210 USER Guides-Flowcharts-Samples.

C-8. Replacement

If a LS machine is inoperable, contact the CRC HRC IT Service Desk at 1-877-272-1330. The desk will assist in determining if there is a hardware or software issue and work to resolve a software issues. In the event of a hardware issue, contact the Bn Information Management Office (IMO) or S4 for a replacement device or parts.

The S4 or the IMO will submit a trouble ticket to the CSC for device replacement. Upon receipt of a replacement, email the new machine serial number and RSID with physical address to usarmy.knox.usarec.list.hq-g6-desktop-support-team-mgmt. In the interim, utilize a neighboring station’s LS device to capture and submit FPs if applicant processing is delayed pending device replacement.

NOTE: Refer to Appendix M (Waivers) for Policy Agency Listing (PAL).

Appendix D

Quality Control (QC) Procedures and Scheduling of Applicants

D-1. Purpose

Outlines the processes to ensure complete and accurate enlistment records and applicant scheduling procedures. During all QCs, the inspector will check the entire record and identify all errors rather than stopping and returning the record at the first identified error. This step reduces multiple returns for record corrections.

D-2. QC Procedures

a. Station Commander Quality Checkpoint (a Power-Point instructional slide deck can be found in the EEPD Document Library by following the link:

<https://span.usarec.army.mil/sites/HQ/G3/EEPD/BattleReadyResources/Shared%20Documents/Forms/AllItems.aspx>

(1) A new functionality has been added to RZ that enables a recruiter to notify their Station Commander (SC) when an applicant’s electronic record is complete and ready for the SC to conduct their Quality Checkpoint (QC).

(2) Station level users will have a new link added to their “My Apps” dropdown menu and the “I Want To” section of the RZ Profile screen that helps facilitate the QC process.

(3) There will not be any changes to the way a user at the station level enters RZ to look at an applicant’s record.

(4) Although this is intended primarily for users at the station level, it is beneficial for all users involved with projecting and QCing records to become familiar with this process.

b. Applicant Profile Screen

(1) Recruiters must ensure each section of the applicant profile screen is marked “Complete” before the “Initiate Station Commander Quality Checkpoint” button will appear at the bottom left of the screen. Click this button to begin the QC process.

(2) After the “Initiate Station Commander Checkpoint” button is clicked, it will change to read “Station Commander Checkpoint Initiated”. Once the user leaves or refreshes this screen, the entire Perform Station Commander Quality Checkpoint section of the page will disappear entirely because the SC Checkpoint was initiated. At this point a system generated e-mail will automatically be sent to the SC and the ASC informing them that there is a record awaiting their QC.

Note: When conducting a QC, you should have access to the applicant’s ENSQ and all information that is used to build the record to ensure every correct source document is properly uploaded in the record.

(3) Notifications and requests can be viewed o at the upper right side of the IKROme page to the right of the “My Apps” link. This is the same location you currently go to view new USAREC Messages awaiting your review. Click on the number inside the box to open the Notifications and Request. You will be able to view of click and read a short-summary about each item that is in your box.

(a) QC Inbox

1. The SC will open the “My Apps” drop down menu and click on the “QC Inbox” link. This is the preferred

method to start a QC at the station level.

Note: Everyone in the recruiting station (RS) will have this link available on their “My Apps” drop-down menu.

2. Once at the QC inbox screen, the user can view the upper left side of the screen to see the number of records awaiting QC. This will be shown by a number listed to the right side of the “Station Commander” dropdown. The SC can click on the “+” sign to the left to reveal a drop-down with each individual record. Click on the record you want to QC and you will be taken to the “Checkpoint Summary: Process Checkpoint screen”.

(b) Checkpoint Summary: Process Checkpoint screen

1. Once the user is at the “Process Checkpoint) screen. There will be a status column to the left side of the screen to help identify where the record is in the QC process. The status is shown by using a color scheme with the following colors:

- Yellow - indicates the person is working/reviewing the packet.
- Gray – indicates the record has not been assigned to that person yet.
- Green – review complete and approved by that person.
- Red – indicates the review has been disapproved and more action is required by the projecting organization.

2. Recruiting personnel can also access the “Checkpoint Summary” screen by clicking the “Process Checkpoint” hyperlink under the “I Want To” section on the applicant’s “Profile” screen.

Note: This will bypass the QC Inbox that shows the total number of records that are in need of a QC at the station level.

(c) Checkpoint “Detail” screen

1. The primary focus of the “Checkpoint Detail” screen is to ensure all required documents are properly scanned into the applicant’s record. The “View Packet” button can also be used to view the source documents in the “Upload Document” screen. Using the View Packet button enables you to approve/disapprove documents and enter comments (specifically about why a document is disapproved).

2. The Document Selection dropdown menu is only displayed for the RSID personnel associated with the record. If a document in the list has not been uploaded, the document name is greyed out. When a document selection is made, the Document Link, Approved By, Approval Date, and Comments auto-populate.

(d) Record “Detail” screen

1. This is where the SC accepts or does not accept the source documents scanned in by the recruiter. The SC will also update the Comments to make remarks about each document. The “Return to Profile” hyperlink will take you back to the applicant’s Profile screen (their ENSQ information).

2. When it is determined that all required documents are uploaded properly, click the “Take Action and Lock Checkpoint” button found at the bottom of the Checkpoint Detail screen. If the “Take Action and Lock Checkpoint” button is greyed-out, then a required source document is missing.

(e) Perform Action Screen

1. The “Perform Action” screen is displayed after all applicable documents are approved and the “Take Action and Lock Checkpoint” button has been clicked. The only option available to the SC is the “Go Packet” selection. SC must annotate comments in the comment section. Click the “Complete Action” button to complete the Station Commander Quality Checkpoint or clicking the “Cancel and Unlock” button, will cause this portion of the screen to go away and revert back to the Checkpoint Detail screen; click this button if the packet is not a “GO” packet.

Note: After the SC clicks the “Complete Action” button that means the record is ready for projection. A dep-in projection can be completed, even if the SC did not complete their QC. The SC must let the recruiter know the packet is ready to project or discuss issues that need to be fixed. An automatic email notification WILL NOT be generated from the SC to the recruiter.

c. Guidance Counselor Quality Checkpoint:

All enlistment records are reviewed by a qualified GC and given either a ‘Go’ or ‘No-Go’ status.

(1) Initial QC (GC). A GC QC workflow initiates when a recruiter projects an applicant for DEP-in.

(a) Run the validation report to check the enlistment record for any administrative errors. LS results must be present and favorable at the time of DEP-in QC.

(b) QC the record and either approve (‘Go’) or disapprove (‘No-Go’) the record. A projection is not considered a ‘Go’ until all information on the source documents has been verified against the information in the record. Ensure all documents in the applicant's ERM are legible and uploaded from original documents, court-certified copies or legible photocopies, and uploaded right side up. GCs will validate that all source documents are legible and uploaded in the proper ERM folders and required government seal(s) and/or file number(s) are visible. GCs will

(2) ‘No-Go’ the record for illegible documents.

(a) DEP-in QC and DTP-accession QC (GC): Workflows are initiated by pulling a permanent reservation for the RA and completing the DA 5435-R (Statement of Understanding -The Selected Reserve Montgomery GI Bill) for AR applicants.

(b) SGC will ensure all documents needed for +10 QC are scanned into records

(c) DEP + 10 QC by Bn Ops:

1. The DEP + 10 QC workflow is automatically generated on the tenth (10th) day after enlistment, accession or DS of the applicant.

2. This QC is completed NLT the first working day after receipt of the DEP + 10 QC workflow.

3. This QC includes but is not limited to:

- Updated MEPCOM 680-ADP uploaded in ERM
- Original DD Form 2808 with DAT and HIV results, DD 2807-1, DD 2807-2, and any other medical documentation.
- FP submission and results
- Security Investigation submission and acceptance
- Validation of MOS qualifications
- Review of the Difference Report for changes in the record
- Any other official forms/documents required by appendix E.
- Law violation mismatch: Listing all law violations in RZ, however not listing violation(s) correctly in corresponding RZ questions.
- Drug use mismatch: Listing drug use in RZ, however not listing drug use correctly in corresponding RZ questions.
- When errors are found, the Bn Ops disapproves the workflow and provides remarks. The disapproved workflow is returned to the GC for corrective action. The GC will follow-up with corrective action(s) within three (3) processing days of notification. The Bn Ops immediately regenerates a new QC for that record. The GC will follow-up with corrective action(s) within three (3) processing days of notification by regenerating a new QC. The BN Ops will ensure corrective action(s) were completed on the fourth (4th) processing day.

d. Before Ship QC (GC): Between seven (7) and 30 working days prior to the FS's scheduled AD or IADT date, GCRC will place the FS's enlistment record in the GCRC inbox. The GC will review the enlistment record for completeness and accuracy. During the Before Ship QC the GC shop will conduct a verification of all source documents in ERM. The GC will validate that all source documents are uploaded in the proper ERM folders and are legible; government seal(s) and/or file number(s) must be visible. If any documents are missing the GC annotates this in the text box of the GCRC QC workflow. The review generates an email from the reviewing GC to the station.

(1) Verify the REQUEST reservation.

(2) Verify the qualifications for options and programs selected.

(3) Review the medical data on the DD 2807-1, DD 2808, UMF 40-1-15 and the GCRC 680-3ADP.

(4) Verify the FS's MOS qualifications per DA Pam 611-21, AR 601-210, and applicable messages.

(5) Verify the FS's OPAT Consent Form, scorecard, and PDC are within 90 days of ship date and that the FS is still qualified for their MOS based on OPAT PDC achieved.

(6) Ensure FSs enlisting for SLRP have a completed UF 601-210.13 uploaded in ERM.

(7) Verify the status of the FS's MEPS FP results and background investigation submission status.

(8) Review the enlistment record for completeness and accuracy IAW the applicable appendixes of this regulation and AR 601-210.

e. Ship QC (SGC). The SGC will conduct his or her portion of the enlistment interview and approve or disapprove the QC and review the applicant's DD 4/3 with the applicant.

(1) During QC procedures, the GC will place emphasis on comparing the applicant's source documents to the applicant's data contained in RZ and the GCRC 680-3ADP data to ensure the following data matches:

(2) Personal information (to include derived names).

(3) Education.

(4) NPS or PS status.

(5) MOS (if MOS was reserved via temporary reservation).

(6) Correct any discrepancy in the GCRC record and the enlistment documents before the applicant selects a MOS, temporary reservation is converted to permanent, or enlists.

f. Once the GC completes the QC, an email message is generated from GCRC to the recruiter, station commander, 1SG and Company Cdr informing them of the record status and additional documents that may be required.

D-3. Projection Rosters

Local MEPS policy will dictate projection rosters (UMF 727-E), the specific cutoff times for different projection rosters and the number of walk-ins allowed.

D-4. Scheduling of Applicants for Processing

a. When an applicant is projected for enlistment, four levels of validation are automatically performed by GCRC and an e-mail is sent to the 1SG, Company Cdr, station commander, and the recruiter initiating the projection. The email provides the status of the projection, validation levels passed or failed, and the exact reason for failure. The recruiter must make the corrections and revalidate the applicant's record. Recruiting personnel are not authorized to enter false data in the record in an attempt to pass validation. The station commander validates completion of all the corrections and the presence of a Parental Consent (DD 1966), if required. The recruiter is then authorized to re-project the record as required.

b. Applicants projected for "Other" processing may continue to process to enlist on the day of their scheduled other processing with Bn Cdr Authorization.

c. Upon confirmation of all projections for the day by the GC shop, submit a UMF 727-E to the supporting MEPS using MEPCOM Integrated Resource System (MIRS) after ensuring all entries are complete and accurate IAW USMEPCOM Regulation 715-4.

NOTE: See appendix M-2 for same day administrative or conduct waiver processing.

D-5. Scheduling of Oral Proficiency Interview (OPI) Processing

a. SGCs must register and schedule OPIs through the OPI Authorization and Reporting System (OARS). Only the SGC at each MEPS is authorized to register for OARS. Associate accounts for other OPI schedulers are authorized under the SGC's account. Authorized OPI schedulers eligible for full access associate account include GCs and Bn Ops personnel. Each station is authorized on limited basis associate account for scheduling OPIs. The web address for OARS is at the following link: <https://oars.languageTesting.com>. Required registration information:

- (1) Service Branch: Drop-down menu; Army 09L/MAVNI
- (2) Location: Drop-down menu; select appropriate Z MEPS ID "ZXXXX- XX MEPS SGC"
- (3) TCO #: Use appropriate Z ID number (5-Digit ID Number)
- (4) Email: Enterprise email address (.mil email address)
- (5) DLPT test site ID: Use appropriate Z ID number (5-Digit ID Number)
- (6) Group ID: Use appropriate Z ID number (5-Digit ID Number)
- (7) User type: GC
- (8) All other fields self-explanatory

b. Allow up to 72 hours for registration/account activation. The SGC will receive an email notification from an OARS administrator when the account is activated. Once activated, SGCs and associated OPI schedulers must request OPIs through OARS.

c. Recruiters must complete the OPI request form and forward it via encrypted e-mail to the SGC or other authorized OPI scheduler. OPI request dates must be a minimum of five (5) business days from the request submission date. OPI requests within the five (5) business day window will be disapproved. The SGC, or authorized OPI scheduler, submit the OPI request via OARS. The recruiter is notified by Bn Ops or MEPS test administrator of the date and time of the scheduled OPI. Download the MAVNI and 09L OPI request forms as well as the OARS OPS schedule instructions from the USAREC Language Page at:

<https://span.usarec.army.mil/sites/HQ/G3/EEPD/SitePages/Language.aspx>.

d. Use the 5-digit test site Z ID number for all OPI requests.

e. OPI Results: OPI results are emailed within 72 hours of date of testing. The DA 330 is the only authorized OPI results OPI results form for MAVNI or 09L enlistments. OPI results produced from OARS are not accepted.

f. Test Proctoring: The only personnel authorized in the test room during the OPI are the proctor and the applicant. Cellular phones, computers and other electronic devices are not allowed during the OPI.

(1) 09L OPI: Conduct all 09L OPI exams at the MEPS. 09L OPI exams include a Reading Comprehension Screening Test (RCST). The RCST is a controlled item and is inspected after each use for any unauthorized markings or tampering. Authorized proctors for 09L OPI/RCST are limited to SGC/GCs only.

(2) MAVNI OPI: Conduct all MAVNI OPI exams at the MEPS or the Bn. Authorized proctors for MAVNI OPI are limited to GCs and Bn Ops personnel.

(3) English OPI: Send all English OPI requests via unencrypted email to Defense Language Institute English Language Center (DLIELC). Do not use OARS when scheduling an English OPI. No English OPI request dates within five (5) business days from the request submission date are authorized. Conduct English OPI exams only at the MEPS or the Bn Ops section. Authorized proctors for an English OPI are limited to GCs and Bn Ops personnel.

Download the English OPI request form and form instructions (which include POCs) from the USAREC Language Page.

g. Cancellations: SGCs or associated OPI schedulers must check OARS daily for changes or updates to the OPI exam schedule. Coordinate rescheduling and cancellation of testing with Defense Language Institute Foreign Language Center (DLIFLC) or DLIELC as soon as possible.

Appendix E

Procedures for Enlistment into the Delayed Entry Program/Delayed Training Program/Delayed Status (DEP/DTP/DS)

E-1. Purpose

This appendix outlines procedures used in the enlistment of applicants into the DEP/DTP/DS.

E-2. Reception of Applicants

The GC shop executes:

- a. Check-in of all applicants upon arrival at MEPS and verification of all required documents in GCRc.
- b. Collection of any required enlistment and ship documents from applicants.
- c. Provides all shippers with their original DD 2807-1 and DD 2808.

NOTE: Once the MEPS control desk has checked in the applicant, update the GCRc processing list with the applicant's arrival status.

E-3. Station/MEPS Processing Drug and Alcohol Test (DAT) Requirements

a. Station responsibilities: The station will implement the Pre-Accession Drug Screening program. This program will assist recruiter's professional processing of applicants by the utilization of a voluntary drug screening kit which will be administered 3 to 7 days prior to the MEPS physical. All recruiting personnel will ensure that applicants and Future Soldiers (FS) understand the principles of the Army Substance Abuse Program (ASAP).

(1) The ASAP is a command program that emphasizes readiness and personal responsibility.

(2) Abuse of alcohol or the use of illicit drugs by both military and civilian personnel is inconsistent with Army Values and the standards of performance, discipline, and readiness necessary to accomplish the Army's mission.

(a) Applicants may decline to participate in the program, but all applicants must sign a UF 601-210.15, Army Pre-Processing Drug Screening Acknowledgement and consent form, acknowledging their understanding of the program.

(b) The UF 601-210.15 will be uploaded to the applicants ERM. Recruiting personnel will track drug screening by using the Army Recruiting Station Drug Screening/Test Log, UF 601-210.16. Logs will be maintained at station level.

(c) At the completion of each quarter, completed logs will be forwarded to battalion operations where they will be retained and filed for a period of one year. Both current and closed logs will be items of inspections during all OIPs.

(d) If an applicant is found to be "presumptive positive" he/she will not be permitted to begin processing at the MEPS as currently scheduled. The result of all tests will be annotated in the applicant's record and on the Army Recruiting Station Drug Screening/Test Log, UF 601-210.16. An example of the Army Recruiting Station Drug Screening/Test log can be found at:

https://span.usarec.army.mil/sites/HQ/G3/EEPD/Shared%20Documents/Example_Forms_and_Documents/UF%20601-210.16_RS_Drug_Screen_Test_Log.PDF

1. If test comes back as "Presumptive positive", the applicant will not be allowed to take the MEPS physical for a period of 30 days.

2. The applicant will be administered a second test after the 30 day waiting period. If the test is "presumptive negative" processing may continue.

3. If the applicant is found to be "presumptive positive" on the second test, he/she may be denied further processing and the results will be used in determining the applicant's eligibility for enlistment.

NOTE: Brigades are responsible for monitoring the ordering, stocking, and maintaining drug test kits. Brigades will also ensure that Soldiers receive proper training for use, storage, handling, collection, and testing of drug screening kits.

b. MEPS Responsibilities: Any applicant that refuses to submit to a DAT will not continue processing for enlistment into the DEP/DTP/DS (no exceptions or waiver authorized) IAW AR 601-210, chapter 5. Applicants who fail to provide a urine sample at time of processing must return to MEPS within three (3) working days for a DAT. Any applicant who does not provide a specimen within three (3) work days is considered a "refusal to test". The

applicant is then placed in a 180-day disqualification period beginning from the day of the medical examination. (See Refusal to Test, MEPCOM Reg 40-8, Chapter 2)

c. Ordering Procedures:

(1) The following GSA link will be used to purchase all drug screening kits:

https://www.gsaadvantage.gov/advantage/main/start_page.do

(2) After navigation to the GSA Advantage site, locate the search products box and enter "5 panel urine test strips", then press the "Go" button.

(3) All 5 panel urine test strips authorized for purchase will be displayed consisting of multiple vendors and pricing. Contacting the vendor for "bulk" pricing is authorized.

(4) Orders shall be placed by the BN S-4 and paid by IMPAC Visa. Battalion S-4s are authorized BPA users, and will be responsible for the ordering of kits.

E-4. General Procedures for Enlistment into the DEP/DTP/DS

After the applicant has passed all required MEPS processing (physical and testing requirements), the SGC designates a GC to enlist the applicant. The enlisting GC executes the following:

a. Initiate a new QC to check the Difference Report for discrepancies from the initial QC. If discrepancies are identified notify the SGC for appropriate actions.

b. Reviews the DD 2807-2, DD 2807-1, UMF 40-1-15, SF 86, DD 2808, and DD1966 and will report any discrepancies to the SGC. SGCs will report any unreported medical conditions as noted between the DD 2807-2 and the DD 2807-1 completed at MEPS to the Bn XO or designated unit reporting official. The GC will upload the medical processing forms in the appropriate folders in ERM.

c. The GC informs the applicant that the concealment of any disqualification may result in a fraudulent discharge. Ask all PS applicants if he/she has family members that are or have ever been part of the Exceptional Family Member program (EFMP).

d. The GC will annotate the free flow remarks of the DD 1966 that all information disclosed by the applicant is in the applicant's record and the applicant fully understands the fraudulent enlistment statements.

e. Verify the GCRc 680-3ADP data and make corrections as needed.

f. Make a final determination of the applicant's qualifications based on enlistment eligibility criteria IAW AR 601-210.

g. Submit 680-3ADP data to REQUEST.

h. FSs who require BCT will ship on Monday or Tuesday only.

(1) If a Monday is a scheduled federal holiday shippers will ship the following Tuesday and Wednesday.

(2) This applies to PS, GNPS and all NPS shipping to training.

(3) GCs are required to ensure the ship date is scheduled within MIRS and transportation is scheduled IAW current MEPCOM policy.

(4) Shipper moves outside of the Monday/Tuesday window must be coordinated through your chain of command via the ROC only. Do not move shippers without authorization from the ROC.

NOTE: GCs and recruiters will not change the applicant's general math and general science qualifications to a higher level of math and/or science without supporting educational documents uploaded in ERM. GCs and recruiters will not select "no credit" or "other" for an applicant's math or science unless specifically directed to do so.

NOTE: After any medical actions at MEPS, an updated DD 2808 is required to be uploaded in ERM.

E-5. Reservation Procedures for REQUEST

a. REQUEST is used to secure a reservation for all applicants who have selected a MOS, program(s), and/or option(s) and will comply IAW appendix B-4 pertaining to REQUEST abuse.

b. Every applicant must possess a valid REQUEST reservation prior to enlisting in the DEP/DTP. Although DS is not considered an enlistment; all DS must possess a valid REQUEST reservation.

c. Make reservations only for applicants who possess a valid SSN (with the exception of applicants enlisting with a TIN from certain overseas locations) verified by documentation IAW AR 601-210.

d. **NOTE:** Applicant(s) will not be enlisted for an overseas assignment if they are under the age of 18 prior to the completion of IADT. This restriction applies to any assignment, not within CONUS, Alaska, Hawaii, Puerto Rico and territories in possession of the United States.

e. Recruiters who make an AR reservation will change the "enlistment date" to the actual MEPS processing date within the seven (7) day temporary reservation processing window.

f. If at any time, the applicant's reservation is canceled, the cancellation printout must be uploaded in the applicant's DEP/DTP Admin folder in ERM. ROC counselors will:

(1) Validate the submission to REQUEST of the 680-ADP in the applicant/FS's record in GCRc by reviewing

the applicable REQUEST tabs.

(2) ROC counselor(s) must receive an acknowledgement of validation for accuracy and completeness of the applicant record and that the applicant is fully qualified from the GC prior to providing ROC assistance in making reservations.

g. All members of the DEP (RA) /DTP (AR) with an education code of 11S must have a minimum of 7 days in DEP after graduation prior to ship. All applicants with an education code of 109 must have 7 days in DEP/DTP after the completion of the current school year. Exceptions to policy 109s will be considered based on training availability.

E-6. GC Procedures after Making REQUEST Reservation

a. Ensure the applicant understands the enlistment MOS, TOS, BCT location, incentives, and first duty assignment (if the applicant is enlisting under Program 9B - US Army Station/Unit/Command/Area Enlistment Program).

b. Complete the DD 1966/3.

c. GCRc will place the appropriate statements on DD 1966/3, block 32, IAW AR 601-210.

d. Brief the applicant concerning the requirement of Sure Pay (SF 1199A (Direct Deposit Sign-Up Form) prior to shipping for AD or IADT.

e. For NPS applicants print the following documents for MEPS processing:

(1) DD 1966/1 completely coded for DEP/DTP-in (RA and AR).

(2) A current 680-3ADP with all current data (RA and AR).

(3) The REQUEST reservation sheet for the applicant (RA and AR).

(4) The automated DEP-in enlistment annex (the applicant's copy printed from GCRc) (RA only).

(5) The automated AR enlistment annex (the applicant's copy printed from GCRc) (AR only).

(6) A copy of the DA 5435-R (AR only).

(7) Any changes made to the finalized SF 86 requires the signing of a new Certification of Applicant page.

f. Upon completion of the MEPS pre-enlistment interview (PEI), the SGC, or designated representative, conducts a final review of the applicant's enlistment record.

g. Upon return of the completed DD 4 series, the SGC or designated representative reviews with the applicant the appropriate entries to ensure all data is correct based on the REQUEST reservation and source documents.

(1) The applicant and SGC or designated representative initial any corrections made, except those corrections made in these areas of the DD 4 series where a new DD 4 series is required:

(a) Date of enlistment.

(b) Term of service.

(c) Approval and acceptance.

(d) Confirmation of enlistment.

(2) Have the applicant read, and initial Item 8c of the DD 4. Prior to swearing in, have the applicant initial Item 19 (Initials of Enlistee/Re-enlistee block).

(3) SGC or designated representative completes, signs, and dates Item 14 of the DD 4.

(4) SGC or designated representative uploads all documents in ERM DEP Admin folder.

E-7. Qualified Not Enlist (QNE) Procedures

If the SGC cannot overcome an applicant's objection to enlist, prior to ceasing the applicant's processing the SGC contacts the responsible company leadership or Bn Ops to assist in overcoming the applicant's objections. If the objection(s) are not overcome, cease processing of the applicant.

E-8. GC Actions After Oath

Once the applicant swears in and returns to the GC shop with a signed and completed DD 4 series, the SGC:

a. Confirms the enlistment by reviewing the DD 4 series.

b. Uploads the DD 4/1 and DD 4/2 into the applicant's DEP/DTP folder in ERM.

Appendix F Procedures for Enlisting Prior Service and Glossary Non-Prior Service (Regular Army)

F-1. Purpose

This appendix specifically outlines additional requirements for the processing of applicants considered PS as defined IAW AR 601-210, chapter 3 or GNPS as defined IAW AR 601-210, chapters 2 and 3.

F-2. General

a. ASVAB test all PS and GNPS applicants without valid test scores, to include the AFQT. PS and GNPS applicant may use their original or prior test scores. Use the most recent test scores in cases where the applicant has tested after their original test for enlistment.

b. Prior to accessing from the DS, applicants must have:

(1) Valid DAT and HIV results.

(2) Verification of suitability results, IAW appendix G. If not, resubmit the suitability results.

(3) Current members of the Individual Ready Reserve (IRR) or the Reserve Component (RC) of any service, other than the Army IRR, processing for enlistment into the RA or AR must have an approved DD 368. Refer to appendix F-10 and AR 601-210, chapter 5 for procedures for transferring components and obtaining the DD 368.

F-3. Procedures Unique to PS/GNPS Applicants Enlisting into the DS

a. Process PS and GNPS applicants for enlistment into the RA as directed by DA and the HRC Business Rules. Processing is completed through normal REQUEST reservation procedures.

b. All PS and GNPS applicants enlisting in the rank of E-5 and above require an electronic grade determination IAW AR 601-210, 3-17. The only headquarters authorized to provide a follow-on assignment to these Soldiers is HRC.

c. No applicants with PS enlisting into the active component will be enlisted into the DEP, to include those who have previously enlisted into any RC of the Armed Forces, regardless of the remaining military service obligation (MSO). Place these applicants into the DS.

d. Conduct the enlistment of these applicants IAW AR 601-210 and this regulation, appendix D, with the exception of the following:

(1) Do not execute the DD 4 series at the time of the REQUEST reservation. The DD 4 series is executed at the time of enlistment (ship date). Applicants enlisted into the DS will not receive a DD 4/3.

(2) The GC will complete the following after the REQUEST reservation is completed to enlist applicant into the DS.

(a) The applicant and GC sign the automated enlistment annex.

(b) The applicant signs all applicable pages of the SF 86.

(c) Inform PS/GNPS enlisting from an AR or ARNG unit on a conditional release (DD 368) or PS/GNPS with less than 90-day break in service must have all initial issue when shipping IAW AR 601-210, chapter 2-12.

(3) The GC will complete the following entries at the time of enlistment (ship date):

(a) DD 1966/1, item 17.

(b) The applicant signs DD 1966/3, block 29c.

(c) The GC signs block 31e of the DD 1966/3.

(d) DD 1966/3, items 32b and 33a-f.

(e) All required PS and GNPS statements that are applicable to the applicant are printed in the Remarks section of DD 1966/4.

(f) The DD 368, automated enlistment annex, and the DD 1966 series are hand carried to the AR unit by the Soldier.

(g) The DD 4 series is executed on the date of the RA enlistment (ship date) and provided to the reserve unit along with the DD 368 to facilitate appropriate discharge of the enlistee.

(h) Members of a TPU are not processed unless the appropriate release authority has an approved DD 368.

(i) Do not process members of a TPU unless they have completed IADT and been awarded an MOS. EEPD will work the exceptions request process.

(4) Applicants in a reserve unit that have not completed IADT require a 5-21 exception to AR 601-210, chapter 5-21.

(5) The completed DD 368 is sufficient authority to cancel an AR or ARNG training reservation.

e. Use the DD 368 for applicants serving in a TPU, either AR or ARNG. The authorized RC representative must sign the form.

F-4. USMA ordered to Active Duty.

a. Cadets will follow the assignment instructions on the order provided by USMA.

NOTE: USMA cadets that were ordered to active duty and have received a recoupment notification or debt collection notice for their tuition, must contact the orders issuing authority to address the issue. Applicants in receipt of such documents will not be processed for enlistment as an “ordered to active duty cadet” until the matter has been resolved by the applicant. It is the applicant’s responsibility to request that the recoupment and/or debt collection be removed and updated orders issued. The orders issuing authority can be found on the cadet’s orders

b. Temporary reservations are not authorized. GC must contact the ROC for a reservation. Utilize the recruiting program code of "OR" - Ordered to Active Duty to assist with tracking cadets. Build the code in GCRc and transfer it to the REQUEST record.

c. USMA will provide the disenrolled cadet ordered to AD with the following:

- (1) Notification memorandum directing the cadet to report to the nearest station.
- (2) Copy of AD order from USMA. Official order will have an order number and signature.
- (3) Copy of their separation physical; both the DD 2808 and 2807.

NOTE: The cadet will be a 'no-med'. If any condition is revealed in screening that would normally preclude a 'no-med' enlistment, contact EEPD Policy.

d. Cadets are processed as PS applicants.

e. Cadets are ordered to extended active duty (EAD) in the grade indicated on the order.

f. Cadets who have completed at least 180 days at USMA are considered BCT graduates.

g. Cadets are screened under, and must meet, the current PS ht/wt standards even if the cadet was separated from USMA for ht/wt.

h. All cadets must have a DD 214 and a copy of their discharge order prior to processing.

i. Recruiters will:

(1) Submit a workflow to EEPD Policy within five (5) working days via GCRc for every USMA cadet ordered to AD.

(a) The workflow type will be ‘missing official documents’ regardless of whether or not the disenrolled cadet has hand carried the documents to the station.

(b) Recruiters will receive a response back from EEPD Policy to continue processing after the orders have been verified. If the cadet did not have a copy of his/her orders, Policy will add a copy to the record. If the cadet did not have a copy of the separation physical, Policy will instruct the recruiter how to obtain a copy.

(c) Ensure the cadet meets mental and conduct qualifications. Cadets are processed as “no-med”. (Ensure the cadet meets the retention standards in AR 40-501, chapter 3, Standards of Medical Fitness.)

(d) Pull a Re-enlistment Eligibility Data Display (REDD) Report and upload in ERM. Use the last ASVAB qualifying score.

(e) Complete all information in the SF 86.

(f) Upload source documents required for a PS enlistment in ERM.

(g) Schedule the cadet for processing.

(h) Ensure that the cadet is projected for all required processing. Build and project as a PS. LS results are required. The cadet will not require swear-in or require the execution of DD4 at time of entry into the DS.

NOTE: All cadets will be processed. Notify EEPD Policy immediately if the cadet is disqualified for any reason.

(i) GCs will:

(2) Ensure appropriate projection of the former cadet is made in MIRS and scheduled to process on the UMF 727. Validate the cadet's record and ensure successful completion of the Quality Review Program (QRP).

(3) For initial processing, validate the SF86 and save to the record. Complete all standard form signature pages required prior to sending the record to REQUEST.

NOTE: Ensure the build is completed correctly through the GCRc portion of the 680-ADP prior to saving and submitting the record.

(4) Ensure the information in REQUEST under the PS tab is correct. Contact the ROC for assistance in completing the permanent reservation. If cadets do not have an MOS on their orders, they will select an MOS.

NOTE: Some cadets are considered MOS qualified based on their PS status before entering USMA.

(5) Complete the DA 3286 DS Annex.

(6) Cadets are not entitled to enlistment incentives, to include the Montgomery GI Bill or Post 9/11.

(7) Upon completion of DS Annex, ensure the former cadet completes the necessary checks by FPing by the MEPS Ops.

(8) Provide the ship packet with appropriate documents to the MEPS and ensure the former cadet understands that he/she will return to the MEPS to swear in and ship to training/duty location.

(9) The DD 4 is executed when the cadet returns to ship.

(10) Complete the DA 3286 DEP out.

(11) Validate SF 86 with signature pages and complete the DD 1966.

NOTE: Ensure the former cadet is eligible to be ship verified with correct JPAS prior to ship.

(12) Ensure the enlistment rank is as indicated on the order.

(13) Ensure former cadets with an assigned MOS and TOS form USMA have the MOS and TOS correct in the REQUEST reservation. (Contact the ROC if any discrepancies.)

(14) Ensure the MEPS is furnished copies of appropriate documents to include any amendments to the orders to AD.

(15) Once the former cadet ships, send the completed DD 4 back to USMA G1 as indicated on the orders.

j. EEPD Policy will:

(a) Contact USMA G1 for amendments to the orders, if applicable.

(b) Contact USMA G1 immediately for disqualified cadets.

F-5. Reserve Officer Training Corps (ROTC) Cadets Ordered to AD

a. Procedures for processing ROTC cadets ordered to AD only applies to disenrolled ROTC Scholarship recipients ordered to AD. Temporary reservations are not authorized. GCs must contact the ROC for a reservation. Utilize the recruiting program code of "OR" - Ordered to Active Duty to assist with tracking cadets. Build the code in GCRc and transfer it to the REQUEST record.

NOTE: Sister Service ROTC disenrolled cadets ordered to AD will be processed the same as Army ROTC disenrolled cadets ordered to AD. ROTC cadets that were ordered to active duty and have received a recoupment notification or debt collection notice for their tuition, must contact the orders issuing authority to address the issue. Applicants in receipt of such documents will not be processed for enlistment as an "ordered to active duty cadet" until the matter has been resolved by the applicant. It is the applicant's responsibility to request that the recoupment and/or debt collection be removed and updated orders issued. The orders issuing authority can be found on the cadet's orders

b. Army ROTC processing includes the following:

(1) Cadets are disenrolled from ROTC and ordered to AD by US Army Cadet Command (USACC). Copies of the AD orders are provided by USACC.

(2) Notification order is issued to the cadet to report to the nearest station by USACC.

(3) Recruiters conduct eligibility screening, to include mental and physical qualifications. Cadets must have a DD 785 (Record of Disenrollment from Officer Candidate-Type Training) and a copy of their discharge order prior to processing.

NOTE: USAREC is responsible for conducting all screening related to MOS assignment, to include medical examination and dependency. For conduct (moral issues), USAREC is responsible for conduct that occurred after disenrollment but not during ROTC or for the reason of disenrollment. The orders to AD constitutes a waiver (if applicable). If cadet was disenrolled for major misconduct, the recruiter must contact EEPD Policy immediately.

(4) Schedule the cadet for the ASVAB if the cadet has never tested or requires to be retested. Cadets must classify as an I-III/A/B (CAT IV not authorized). Schedule the cadet for any other special testing required.

(5) All cadets must be medically qualified. Cadets are projected for a full accession physical at the MEPS. The DD 2807-2, current ROTC physical, medical records, etc., are provided to the MEPS medical personnel for QRP in advance of the projected processing date. Schedule the cadet for the Airborne screening physical, Armed Forces Vision Test (AFVT) or any other additional physical testing that may be required for the cadet to qualify for a specific MOS.

(6) Cadets must meet physical standards to include ht/wt. Cadets without PS are screened under current NPS ht/wt standards.

(7) All cadets are processed as PS applicants. Cadets can enlist at a higher grade than what is indicated on the orders if they provide transcripts with credits that show they qualify for advanced grade.

(8) For additional processing steps for a cadet ordered to AD refer to appendix E-5.

NOTE: Cadets who receive orders directing them to AD may be directed to serve a required length of time (TOS can vary) that the former cadets are required to complete. For example; 24/36/48 months. If a cadet is ordered to serve 36 months or less and requires training, the cadet can only select an MOS with a TOS of 36 months. The ROC will make and update the reservation removing the training time associated. DD Form 4 will reflect the "even number with no weeks" for those who have a committed TOS. If the cadet chooses an MOS with a TOS longer than the time instructed on the orders, the cadet must acknowledge it. GCs must indicate by annotating in the free form remarks "____ has been counseled and acknowledges the commitment time of service for the MOS selected exceeds the time of service reflected in their orders to AD." In the cases where the cadet selects an MOS with a longer TOS than what is on the orders, the DD 4 will reflect the "even number with weeks" TOS.

F-6. Disenrolled ROTC Cadets Requesting to Enter Active Duty

Processing of ROTC Scholarship or non-scholarship contracted cadets that have disenrolled and are requesting enlistment to AD. This does not apply to those cadets that have been ordered to AD.

a. A ROTC cadet who has disenrolled from a ROTC program and who has not been ordered to AD and desires to enlist in the RA, may enlist under the following guidelines:

(1) The cadet must have a completed and signed DD 785 along with discharge orders from USACC before processing can be initiated.

(2) Have a valid ASVAB and any other required special test result.

(3) The cadet is informed that they are entitled to bonuses that are associated with the MOS they enlist for IAW the current USAREC messages.

(4) The cadet is informed that they are not eligible for SLRP.

b. For cadets requesting enlistment to AD, the recruiter and GCs will:

(1) Indicate on the 680-3A-E and the 1966 Series (blocks 22B and 24A) that they are PS and have participated in ROTC.

(2) Build the record in GCRc and RZ as GNPS with "1" day of service for those who have no Active Federal Service (AFS).

(3) Build record in GCRc and RZ as PS with the actual amount of days of AFS for those that have fewer than 179 days of AFS time.

c. Applicants who have served on AD for more than 179 days are defined as PS. These applicants are processed IAW current HRC Business Rules and are not entitled to incentives.

F-7. Processing Disenrolled Service Academy Applicants Not Ordered to AD:

Processing of Disenrolled Service Academy applicants not ordered to AD. This does not apply to USMA cadets ordered to AD.

a. Disenrolled Service Academy applicants who have not been ordered to AD and desire to enlist RA, may enlist under the following guidelines;

(1) Applicants must be released without a remaining MSO.

(2) Applicants will be processed as GNPS/PS IAW AR 601-210.

(3) Applicants will be processed IAW the current HRC Business Rules.

b. Applicants currently in an Academy pending discharge are not eligible to process until they are in receipt of their DD 214.

(1) The applicant's DD 214 will not reflect an RE Code but will have a narrative reason and authority for separation.

(2) If the DD 214 reflects a narrative reason listed in AR 601-210 that requires a waiver, the waiver must be initiated and processed through normal channels.

NOTE: Current open/closed categories and waiver restrictions apply.

c. GCs will be advised of the following:

(1) Applicants are not entitled to any enlistment incentives.

(2) Applicant's pay grade will be determined by the amount of college credit the individual has IAW AR 601-210 only.

(3) Applicants must attend BCT if he/she has not completed 180 days or more as a cadet at West Point. Attendance time as a cadet can be found on the DD 214, item 18 (remarks).

(4) Cadets who have been separated for three (3) years or more from USMA must attend BCT. Cadets from the other Services must attend BCT.

d. Questionable cases concerning processing must be submitted via workflow to EEPD Policy. All reservations must be made through the ROC.

F-8. Processing Warrant Officer Course (WOC) Selectees from Sister Services

a. If a currently serving member of any Service decides to pursue the Army WOC, they must submit an application, sit before a selection board and receive a selection notification for the program.

b. The phases of processing for WOC:

(1) The selectee completes an application packet. The application packet is reviewed and evaluated for selection by a centralized board.

(2) The selectee is notified by HRC.

(3) All required testing of the selectee is completed during the application process.

(4) Selected candidates take the physical as part of the application process. Selectees must have an HIV

screening within two years. Selectees must meet PS ht/wt standards.

(5) Upon notification of selection by HRC, selectee immediately report to nearest station and provide recruiters with the selection packet and required documents for enlistment.

(6) The GC must contact the ROC for a reservation.

(7) The selectee is scheduled to ship to BCT based upon the reservation.

NOTE: BCT is required for all PS personnel entering the RA, regardless of component who have not completed an Army BCT, US Marine Corps (USMC) Basic Training, completed training for Air Force or Navy Special Operations Forces, or Air Force Security Police.

c. Station commander/recruiters' actions:

(1) If necessary, assist the potential selectees in obtaining an approved DD 368 through their Servicing Personnel Office. Verify the DD 368 has a projected RE Code, SPD code, ETS, Air Force Specialty Code (AFSC) or Navy Rate, and annotation of any lost time in whole days, provided in the Remarks block on page 2 of the form.

(2) Obtain a REDD Report and upload in ERM. Use the last ASVAB qualifying score for the selectees.

(3) Upload documents required for enlistment in ERM. Include the selectee's complete physical.

(4) Project the selectee for all required processing. LS results are required. Selectees will not require swear-in or require the execution of DD 4 at time of entry into the DS.

d. GC actions:

(1) Ensure selectees have a current security clearance. DO NOT initiate an SF 86.

(2) Ensure that the enlistment occurs the day after separation from the parent Service.

(3) Break in service is not authorized.

(4) Selectee must have a completed DD 214 and discharge orders from their Service on ship day.

(5) Ensure the selectee enlists in the Army at their present grade and for a period of four (4) years.

(6) Provide selectee school reporting information:

(7) HHC, Warrant Officer Career College (WOCC), Building 5910, Ft Rucker, AL.

(8) Movement of dependents at government expense is authorized provided selectee is eligible under JFTR. Travel by POV is authorized.

(9) Hand-carry their complete MPRJ to Ft. Rucker, AL.

(10) Uniform issue is obtained at Ft. Rucker.

(11) Rations and quarters are available and must be utilized.

(12) An information and welcome packet is found at: <http://usacac.army.mil/cac2/WOCC/>

(13) Ensure the MEPS Cdr is furnished copies of appropriate documents as listed in c and d above to include amendments to the AD orders.

(14) Once the selectee ships send the completed DD 368 and DD 4 back to appropriate Service.

e. GCs and recruiters can find inter-service transfer information at: <http://www.usarec.army.mil/hq/warrant/>

F-9. Processing Procedures for Applicants from Sister Services

Processing procedures for applicants from all other Services IAW HRC Business Rules.

F-10. PS Applicants Processing Who Require a Conditional Release, DD 368

Applicants processing for enlistment into the RA or AR and are current members of the IRR or RC must have an approved DD 368 prior to processing for enlistment. This excludes the Army IRR. Applicants who are in the Army IRR who desire to transfer into a TPU will be given to the local 79V Retention and Transition NCO at a local reserve unit.

a. US Marine Corps (USMC) IRR members must be released from the IRR with the approval of the appropriate approving authority IAW MCO 1001R.1L.

(1) Submit requests via email with the DD 368 attached through the following: mcirsa_ima@usmc.mil.

(2) The completed DD 368 will have the first five (5) digits of the SSN blacked out.

(3) Once the request has been submitted, allow at least five (5) days for processing.

(4) MARCORRES customer service is (800) 225-5082.

(5) The SGC will ensure the Soldier's DD 4 is forwarded to the email address above within 24 hours of Soldier shipping/accessing.

b. US Navy (USN) IRR members must be released by the Cdr of the naval district where the person is assigned or the Chief of Naval Personnel.

(1) Email ATTN to HR Assistant Conditional Release: Pers-913_DD368@Navy.mil.

(2) The completed DD 368 will have the first five numbers of the SSN blacked out per USN's PII policy.

(3) Once the request has been submitted, allow at least one week for the request to be processed. The customer service number is (866) 827-5672.

(4) The SGC will ensure that the DD 4 is forwarded to the above email address within 24 hours of the Soldier shipping/accessing.

c. US Air Force (USAF) IRR members must be released as follows:

(1) Fax the DD 368 to (478) 327-2215, must include a fax cover sheet. Or mail to: 18420 E. Silver Creek Avenue, Building 390, Mail Stop 68, Buckley AFB, CO 80011.

(2) SGC will ensure that the DD 4 is forwarded to the above address within 24 hours of Soldier shipping/accessing.

(3) Air National Guard members. Unit Wing Cdr.

(4) Air Force Reserve members. Unit Wing Cdr.

d. Coast Guard (CG) IRR Conditional Release:

(1) Website address. <http://www.uscg.mil/rpm/rpm3/irr/>

(2) Mailing address: Commander (RPM-3) Personnel Service Center US Coast Guard Stop 7200
4200 Wilson Blvd STE 1100
Arlington, VA 20598-7200

(3) The SGC will ensure that the DD 4 is forwarded to the above address within 24 hours of the Soldier shipping/accessing.

e. ARNG. The approval authority for Soldiers assigned to the ARNG will be the state MILPO/G-1 IAW: National Guard memo dated 15 October 2010. Adjutants General may delegate the approval authority to grant a DD 368 below the first GO in the chain of command. The SGC will ensure DD 4 is forwarded to the appropriate State Adjutant General and send an information copy of the DD 368 to the losing ARNG command indicated in item 1 of the DD 368 within 24 hours of the Soldier shipping/accessing.

f. AR TPU Conditional Release. All requests for conditional release will be submitted through the Soldiers' chain of command to the approving authority.

(1) The approval authority for DD 368 (Conditional Release) for AR TPU Soldiers with less than 12 months of Selected Reserve time or those still in training is USARC G1. The approval authority for MOS qualified TPU Soldiers with more than 12 months of Selected Reserve is the Geographic or Functional Commander (GFC). GFCs may not delegate this authority per Chief of the Army Reserve Memorandum.

(2) The SGC will ensure that the DD 4 and DD 368 is forwarded to the appropriate TPU as indicated in Item 1 of the DD 368 within 24 hours of the Soldier shipping/accessing.

g. The SGC will ensure that the DD 4 and DD 368 is forwarded to the appropriate TPU as indicated in Item 1 of the DD 368 within 24 hours of the Soldier shipping/accessing.

h. Prior approval from HRC EIS if enlistment grade is E-5 and above.

i. NOTE: Refer to AR 601-210, chapter 3-17b (3) for proper procedures on processing an enlistment if pay grade is E-5 or above.

j. RA Applicants who are current members of the Army IRR will have a DD 368 completed on their ship date. The ship GC forwards a hard copy or emails a copy of the completed DD 4 and the DD 368 to the address below within 72 hours of ship date: Commander, HRC, 1600 Spearhead Division Avenue, Department 364, AHRC-EPF-M, Fort Knox, KY 40122 Email: usarmy.knox.hrc.mbx.epmd-irr-separations@mail.mil.

k. Obtain additional contact information for DD 368 releases by accessing:
<http://span2010.usaac.army.mil/pub/RC-G3/Div/Pages/Policy.aspx>

F-11. Movement of GNPS/PS Soldiers from Place of Enlistment

MEPS GCs will ensure that all shippers departing their AO are being routed to the appropriate training location. When errors are identified that would result in a Soldier reporting to the incorrect location, the SGC will coordinate with EEPD-ROC and the local MEPS Recruit Travel Office to remedy the orders and transportation.

a. All standard training path shippers holding MOSs identified in Table F-1 below, will be shipped to the RECBN/BCT location as indicated.

Table F-1 Standard Training (BCT/AIT) shippers

MOS	RECBN/BCT Location
12D	Lwood
12M	Lwood
15Q	Jackson
15W	Jackson

Table F-1 Army Reception List

b. Except as indicated in paragraph F-11, c. below, AIT only Soldiers, Alternate Training Program (ATP) Phase II and GNPS/PS, are not authorized to report directly to a non-Army installation for training. Soldiers requiring AIT only whose training will not be conducted at an Army installation will be shipped to the RECBN listed in Table F-2 below.

c. Army School of Music (SOM):

(1) ATP Phase II Shippers will ship directly to the SOM, Naval Amphibious Base (JEBLC-FS). Coordination will be made to ensure the shipper arrives no earlier than the Friday prior to the class report date.

(2) GNPS/PS AIT only shippers will ship to RECBN Jackson seven (7) days prior to the class report start date for in-processing. RECBN Jackson will coordinate transportation to SOM, Naval Amphibious Base (JEBLC-FS).

Table F-2 Non-Army Installation AIT RECBN list for AIT

AIT	Reception BN
Presidio of Monterey, CA	Lwood
Gulfport Naval Station, MS	Lwood
Sheppard Air Force Base, TX	Sill
Pensacola Naval Base, FL	Lwood
Eglin AFB, FL	Lwood
Good-fellow AFB, TX	Lwood
Panama City Coastal System Station, FL	Lwood
Ophthalmic Support and Training Activity, VA	Jackson

Table F-2. Non-Army Installation AIT RECBN list for AIT

Appendix G

Applicant Background Screening (ABS): Technical (tech) Check and National Agency Check and Local Check (NACLC)

G-1. Purpose

This appendix outlines the process to ensure proper background submissions (tech check and NACLC) and required actions by GCs and Ops personnel.

G-2. General

Bn Cdrs are responsible for the overall ABS program of the unit.

G-3. Primary Purpose for Submissions

Tech check, which is defined as the MEPS fingerprint submission and NACLC submissions are requests for applicant conduct information from the Army to Office of Personnel Management (OPM) and the FBI. Tech check results are required within DEP plus 7 days, acceptance of the NACLC submissions is required to take place within 14 days of enlistment into the DEP/DTP/DS, or sooner if ship date is prior to 14 days from permanent reservation.

a. The enlisting MEPS or BN responsible for suitability procedures at that location is responsible for the successful submission of all NACLC and secret clearance investigations not covered in b. below. MAVNI Single Scope Background Investigations (SSBIs) are also the MEPS/BN responsibility when the program is open.

b. Security Interviewers (SI) located at Personnel Security Screening Program (PSSP) detachment at Fort Knox

are responsible for the successful submission of all Tier 5 (top secret (TS) SSBI, with the exception of MAVNI)), Personnel Reliability Program (PRP), 09S and 09W investigations. Assistance by the station or MEPS will be coordinated from the Fort Knox location. OPM conducts background investigations (BIs) for all Federal agencies using the following submission methods:

- (1) Tech checks: Submitted by MEPS personnel.
- (2) NACLCL: Submitted for applicants requiring no clearance.
- (3) NACLCL and/or secret: Submitted for applicants who require a secret clearance for their MOS.
- (4) SSBI or TS: submitted for all applicants requiring a TS clearance by the SA.

G-4. Tech Check Submissions

- a. MEPS personnel submit tech checks via the electronic LS FP device. It is utilized in determining every applicant's suitability for enlistment.
- b. GCs ensure that all enlistments have FPs captured by MEPS personnel for submission at the time of entry in the DEP/DTP/DS regardless of MOS, option, PS status, or prior security clearances granted. MEPS submits all FPs electronically, provided results have not returned within 120 days of the new submission date.
- c. Tech check results remain valid for the duration of time spent in DEP/DTP/DS.

G-5. Tech Check Results

- a. Case Closing Transmittal (CCT) that reads "FBIF - No Record" means that OPM and the FBI were able to read the FPs and the FPs returned no law violations.
- b. The RAP sheet is a notice sent from OPM alerting the Army that the "subject" (applicant or FS) has charges tied to their FPs. Normally, the RAP sheet returns with the CCT as a separate attachment.
- c. Upload results received into the ENTNAC RAP Sheet folder in ERM. Results typically post within (7) seven days of DEP/DTP/DS status or after following match procedures. Address MEPS personnel or the NACLCL office for assistance with results not returned within seven (7) days for the retrieval of results.
 - (1) The Applicant Background Screening Manager (ABSM) uploads the tech check results into the FS's record and in the Core Admin folder titled ENTNAC RAP sheet folder. Results are part of the ship record. Upload the UF 601-210.10 (secret only) in ERM at enlistment. USMEPCOM 680ADP showing favorable results in the background section RSLT=F or under the work history with a WKID result of B006F can also be used as proof of favorable MEPS FPs by uploading either into the ENTNAC RAP sheet folder.
 - (2) When a FS is a match, and the charges on the RAP sheet are identified in the enlistment record, the ABSM enters "Favorable Suitability Results," date posted, and the ABSM's rank and name using the Remarks menu in GCRc. This requirement is only for FSs who return with a RAP sheet. Favorable results are defined as all of the charges listed on the RAP sheet are listed on the SF 86 at DEP/DTP/DS. If all charges are not listed, process the FSs IAW with appendix G-9a (3).
 - d. A CCT that returns as "FBIF - Unclassifiable" indicates inability of the FBI to read the FPs. FS must then return to MEPS to re-FP within five (5) working days of CCT return. The GC shop informs MEPS that the FPs are a resubmission and ensures that MEPS places the original case number in the Original Case Assignment area.
- e. Results are returned in the MEPCOM Background Investigation Report (BIR) system. To attain access to the BIR, the GC shop requests access through MEPCOM.

G-6. NACLCL and/or Secret Submissions.

- a. An accepted NACLCL submission is required for all applicants enlisting in a MOS not requiring a TS clearance. The Army Personnel Security Center of Excellence (PSCE) must accept the investigation within 14 days of enlistment.
- b. GCRc electronically submits all NACLCLs to OPM the day of permanent reservation processing.
- c. Submit applicants requiring a secret clearance as NACLCL/secret.
- d. GCs complete or ensure the following:
 - (1) Applicant RZ record must pass all levels of validation at the time of submission.
 - (2) Send FPs (tech check); if not, a "PR NAC Info" error is received. If FPs are not received by OPM within 30 days, the NACLCL or NACLCL-secret investigation is discontinued. The FP results for an applicant with previous processing are valid only if within 120 days prior to the NACLCL submission.
 - (3) Ensure SF 86 is completely accurate and in ERM. Applicants review the form for accuracy and completeness and sign within 90 days of enlistment.
 - (4) Verify that the following are digitally signed and stored in ERM:
 - (a) Medical Release of Information Statement
 - (b) Release of Information Statement

(c) Certification of Applicant

(d) Signature Release of Credit Check

(5) NPS applicants require a DEP-in Annex A and Reserve Annex in ERM for a valid submission.

(6) After submission, GCs verify in the "Select a Person screen, JPAS Processing, Messages" of proof of acceptance by Army Investigative Enterprise Service (AIES). A message of "Success-JPAS Status A" is proof.

e. ABSMs review the Clearance Status page daily in BIR Zone to verify the previous day's submissions from their respective MEPS by:

(1) Entering "Reports" in BIR Zone.

(2) Clicking on the "Processing" tab.

(3) Selecting the "Clearance Status" page.

(4) Selecting processing date (run the report using two working days prior to start date for the best information).

(5) Selecting either "Display the Report on the Screen" or "Send via email" to receive the report.

(6) Verify the date displays in the "JPAS Clearance Accepted" block and a statement of acceptance appears on the DD 1966 series upon submission acceptance.

(7) If rejected, the reason for submission rejection appears under "JPAS Processing; Messages" in GCRc. Recruiters then make "AIES rejections" error corrections and resubmit NACLIC/secret clearances. The MEPS/BN with enlistment credit is responsible for the successful submission within DEP plus 14 days. Fort Knox PSSP detachment is responsible for the submission of the TS, PRP, 09S and 09W clearance and will assist stations with corrections. Make all required corrections within 14 working days of the error notification. Resubmission is required until the investigation is accepted.

(8) EEPD, Background Screening Branch can assist GCs in making corrections to the errors returned by JPAS. Contact the Background Screening Branch via email. The GC shop is primarily responsible for corrections and verification of the submission. Failure to make immediate corrections can lead to delays in the FS's ship date.

(9) Include the error message and the corrected information in the assistance request emails. For example: Place of birth is not consistent with Boyd Crowder, 111-22-3333. Place of birth should be Harlan, KY.

(10) Only Background Screening Branch can correct the following submission errors, via email (if an error outlined in a-c below is received, immediately email the Background Screening Branch for assistance):

(a) SSN or SSN/name mismatch caused by the FPs submitted with different information than the investigation.

(b) Date or place of birth mismatch.

(c) Name is not consistent with SSN.

(d) PID data does not match.

(11) Background Screening Branch clears the information with OPM and submits the investigation.

(12) The GC initiates an UF 601-210.10 (The Security Clearance Questionnaire) for applicants who enlist in an MOS listed in DA Pam 611-21 as requiring a secret clearance (with the exception of 31B/K and 37F). (If DA Pam 611-21 states the clearance level is confidential, follow the instructions for a secret submission.) Applicants are required to answer all questions. Explain all yes answers in detail. Also, all yes responses require a review by the assigned SI except for Question 10 (citizenship). The SGC/GC will sign and approve all UF 601-210.10 that have no yes answers outside of question 10. If the yes answer(s) is for law violations, the SGC/GC will sign the UF 601-210.10 if the law violations are traffic offenses as defined by AR 601-210 only and the number doesn't exceed five (5). The exception to this is for applicants enlisting into OCS or WOFT, SI must interview those applicants and complete the UF 601-210.10. If there is still an assigned SI at the MEPS, that SI, is the approval authority for all that require a secret clearance.

(13) One of the Fort Knox PSSP detachment supervisors are the final authority for questions of qualification for secret clearance. Confirm enlistments only when the SI determination is complete. The completed UF 601-210.10 is uploaded in the Core Admin folder in ERM. All interviews required by the Fort Knox PSSP detachment will be accomplished via phone to 1-833-290-0109.

(a) The SI screens applicants desiring to enlist in a MOS listed in DA Pam 611-21 as requiring a TS or PRP level clearance. FS enlisting in a MOS requiring a TS or PRP clearance must have a completed and approved SI worksheet uploaded in ERM or free form remarks from the SI attesting to the approval to continue to process for a TS or PRP clearance at the time of DEP/DTP/DS. The worksheet must be uploaded prior DEP/DTP/DS. Favorable tech check results and proof of their TS or PRP clearance submission is required to 10+QC ship to IADT or unit of assignment. The SI or PSSP detachment is responsible for the successful submission of the TS or PRP clearance within 14 days of entrance in the DEP/DTP/DS.

(b) Approval for continued processing for secret clearance is annotated in the free form remarks by the SI for FSs enlisting in a MOS requiring a secret clearance or with the UF 601-210.10 marked approved and signed by the SI responsible. MEPS or Bn Ops submit the secret clearance within 14 days of DEP/DTP/DS. Favorable tech check results and proof of clearance submission is required to ship to IADT or unit of assignment.

(c) FSs enlisting in an MOS that requires no clearance will have a NACLCL submitted and accepted within 14 days of DEP/DTP/DS by MEPS or Bn Ops. A favorable tech check and proof of clearance submission is required to ship to IADT or unit of assignment.

(d) Recruiters are responsible to correct all AIES errors returned for action within the required 14 days of DEP/DTP/ DS regardless of the clearance level. MEPS/BN Ops personnel are responsible to follow up with stations and assist them with the correction of AIES errors.

(e) GC shops without an on-site SI will adhere to the following procedures:

1. Validate that the SF 86 is in ERM and contact the supporting SI for an interview. The SI will review the SF 86 in ERM and perform a telephonic interview after the SGC/GC contacts 1-833-290-0109.

2. The SI will inform the SGC and/or GC of the results of the interview and will upload the interview form with the approval or disapproval. The SI may also document the interview outcome in the free form remarks.

(f) During DEP-out procedures, if the GC determines that the FS is no longer qualified for the MOS IAW DA Pam 611-21, the GC will renegotiate the contract or initiate separation of the FS from the DEP/DTP/DS. The GC notifies the SI of the action taken.

(g) MOS 31B, 31K and 37F require PRP screening from the SI. The SI or PSSP detachment process all ETPs for MOS 31B/K and 37F relating to security approval. Proponent approval is not required for security clearance issues. PRP screening approval/disapproval must be uploaded in ERM.

G-7. Processing PS and GNPS.

a. Submit PS and GNPS for a tech check at the time they enlist in the DS provided the previous results are more than 120 days old. If a PS or GNPS requires a level of investigation higher than what they currently hold, FPs are submitted regardless of the date of previous FP results and an email notification is sent to EEPD, Background Screening Branch.

b. Proof of a clearance verified by the SI (performed by a terminal check with the Central Clearance Facility (CCF) or a JPAS check through one of the detachments or the Background Screening Branch) is required for PS and GNPS enlisting Option 18 or in an MOS that requires a security clearance. Proof of clearance is captured and uploaded by the GC into the "Security Clearance Verification" in the Core Admin folder in ERM. Process PS and GNPS applicants that do not hold the clearance level for that MOS in the same manner as a NPS enlistment.

G-8. Processing Enlistment Records after Enlistment

a. The GC shop pulls the BIR report from the BIR system to verify submission acceptance. If, after 72 hours of FP submission, there is no case number, the GC shop must notify MEPS personnel. MEPS personnel verify the FP submission and acceptance at MEPCOM and then transmittal to and acceptance at OPM. In the case that they were not, the GC shop and MEPS commit and submit the FPs at that time. It is imperative that FP acceptance occurs within seven (7) days of DEP/DTP/DS as this also affects the investigation submission. All GCs and Bn Ops must remain current on the status of submission of all FPs.

b. The Bn ABSM reviews the "Clearance Status" page in BIR Zone daily, ensuring the submission and acceptance of required investigations, corrective action for a submission error is outlined in appendix G-6. In cases where the FS does not appear on the Clearance Status page, contact EEPD Background Screening Branch for assistance.

G-9. Procedures for Applicants Identified as a Match (RA and AR)

a. When a RAP sheet is received on a FS:

(1) The ABSM reviews for any discrepancies between the applicant SF 86 and the RAP sheet to determine if all charges listed on the RAP sheet were listed at initial enlistment (DEP-in).

NOTE: Some charges may not appear on the stored version of the SF 86 if the date or offense level is outside the scope of the investigation. The ABSM additionally checks the Entrance National Security Questionnaire (ENSQ) screen to ensure the charges were previously revealed and will check the Difference Report to ensure that items were not entered on the SF 86/ENSQ after the date of the FP submission. If charges were entered after the FPs or investigation was submitted, the ABSM treats the results as a match or fraud.

(2) If all the information on the RAP sheet was revealed and listed in the FS's record, the FS has favorable results. The ABSM annotates the results in the Remarks section of the DD 1966/4 (name, rank, and date posted) using the "Remarks" section in GCRc. Upload the RAP sheet in the "ENTNAC RAP Sheets" folder located in the Core Admin in ERM.

(3) For cases where there are discrepancies between the enlistment record, SF 86, and the RAP sheet, the following procedures are completed:

(a) The ABSM annotates the match on the UF 601-210.07. The ABSM notifies the Bn S-3/Ops SGM or Ops

NCOIC the same day the RAP sheet is received to inform of the match. The ABSM maintains the UF 601-210.07 but does not capture and upload the RAP sheet into the ENTNAC RAP Sheets folder until the Bn Ops interview of the FS is completed.

(b) After verification of a match, the ABSM annotates the UF 601-210.07.

(c) The Bn S-3/Ops SGM or Ops NCOIC is required to contact and interview the FS identified as a match within seven (7) calendar days of notification. The interview determines if the FS intentionally concealed the information and any involvement by recruiting personnel in the concealment. If the FS alleges or the interviewer identifies a RM by recruiting personnel, the interviewer reports the potential RM to the Bn XO, or designated Bn official. If intentional concealment is determined and a conduct waiver is required or charges are open, initiate discharge of the FS IAW appendix I using loss code "FE." The interviewer notifies the Company Cdr and ISG of the interview results; whether the FS is retained or discharged, and which DD 369(s) and UF 601-210.02(s) are needed. Upon determination of the FS as unqualified for retention in the DEP/DS, the Bn initiates the loss the same day. The interviewer prepares a UF 601-210.35 or MFR detailing the interview results. The UF 601-210.35 or MFR includes, but is not limited to; whether the discrepancy was intentional and/or if involvement by recruiting personnel occurred. Upload the UF 601-210.35 or MFR in the "Memorandum for ENTNAC Interview" folder. Retention in the DEP is authorized if the Bde Cdr believes the FS unintentionally concealed the information and an extremely meritorious case exists, see AR 601-210, chapter 4-2f(3).

(4) Notify the ABSM upon completion of the interview. The ABSM then captures and uploads the RAP sheet in the "ENTNAC RAP Sheets" folder.

(5) FSs identified as a match for minor traffic offenses listed in AR 601-210, chapter 4-8, Figure 4-1, do not require retains. If any of the charges are still open, the FS is discharged IAW appendix I using loss code "FE." The GC lists all additional charges in the GCRc record and has the FS re-sign the applicable pages of the SF 86.

NOTE 1: Retain-in-DEP/DS are not authorized if LS results are returned as UNCLASSIFIABLE twice, or if LS enrollment could not occur due to FPs that are too degraded to capture. Retains are not authorized in cases where LS results have returned with a RAP sheet and the SF 86 was not updated with those changes.

NOTE 2: Bde Cdrs have retain authority for conduct cases in which no intent to commit fraud is identified (see AR 601-210, chapter 4-2f(3)).

NOTE 3: The Bde Cdr is authorized to retain and ship applicants enlisting in the DEP/DTP/DS who fail to disclose an offense that does not require a waiver or USAREC suitability review.

b. AR FSs found to have concealed law violations over the level of traffic violations are taken as an Entry Level Separation (ELS).

(1) Process PS who enlists in a "non-train" or "will train" position and subsequently are found to be a match; the ABSM enters the appropriate data on the UF 601-210.07 and informs Bn Ops and the gaining unit. Police and court checks are uploaded in the appropriate folders in ERM. Soldier discharged from the AR as a result of concealed charges incur a six (6) month wait, prior to processing for either the AR or RA.

(2) AR Soldiers who return with charges that are either open or would have resulted in being ineligible for a waiver, had the charges been revealed, are subject to training reservation cancellation. The gaining unit and discharge authority is notified that these Soldiers do not meet enlistment eligibility and will not ship to training.

c. PS/GNPS who enlist with concealed information that requires a waiver, or return with open charges, are discharged from the DS. There is a six (6) month wait from the date of the REQUEST reservation cancellation before the submission of a waiver to reenter the RA or AR. If a waiver isn't required, the six (6) month wait still applies for those PS and GNPS discharged as frauds.

d. Discharge any FS who enlists fraudulently due to intentionally concealed information for fraudulent enlistment. They are required to wait six (6) months from the discharge order publication date before submitting a waiver for enlistment. FSs who were previously discharged for reasons other than fraud and would have been discharged as a fraud (for example; DAT loss) prior to the RAP sheet returning, also incur a six (6) month waiting period before re-contracting.

e. Discharge applicants that conceal open law violations from the DEP/DTP/DS regardless of the level of offense. Discharge as a fraudulent enlistment which requires a six (6) month wait from discharge order publication date to re-contract.

G-10. Procedures for FSs without "Favorable" Tech Check Results and/or RAP Sheets

FSs do not ship without favorable tech check results. Tech check results are required to be obtained within DEP plus 7 days. Corrective action outlined in G-5 is required to ensure results return during this time period. They are renegotiated if tech check results are not received by their scheduled ship date. OPM requires FP results to conduct an NACLIC or security clearance investigation. Prior to renegotiation, contact EEPD Background Screening Branch to validate existence of tech check results. FSs identified as a match while in the DEP/DTP/DS with no charges

listed on their enlistment record cannot ship until a RAP sheet is received. If CCT returns as “Record” and there is no accompanying RAP sheet, email EEPD Background Screening Branch, with the applicant name and SSN immediately and request a RAP sheet. EEPD Background Screening Branch retrieves the RAP sheet from OPM within 48 hours. FSs that are a match and have charges above traffic level listed on their enlistment record, with no accompanying RAP sheet, are interviewed by the Bn Ops and ship with a control number from EEPD, Policy Branch. Background Screening Branch notifies the MEPS and Bn of the issue code. If the given issue code coincides with what is revealed, perform an interview that testifies to the fact that the applicant has no other charges than what is listed on the SF 86, and the Bn Cdr is confident that the applicant is not concealing any information. Record the interview in an MFR.

a. Issue codes:

- (1) 1 - Intoxicants
- (2) 2 - Drug use
- (3) 3 - Financial responsibility
- (4) 4 - Moral Conduct
- (5) 5 - Honesty
- (6) 6 - Violent behavior
- (7) 7 - Employment
- (8) 8 - Firearms or weapons
- (9) 9 - Miscellaneous
- (10) 10 - Statutory debarment
- (11) 11 - Loyalty and security
- (12) 12 - Qualifications
- (13) 13 - Associates
- (14) 14 - Relatives

b. Issue seriousness codes are:

- (1) A - Issues are minor and the conduct or issue, standing alone, would not be disqualifying.
- (2) B - Issues are moderate and the conduct or issue, standing alone, would probably not be disqualifying.
- (3) C - Issues alone are substantial and the conduct or issue, standing alone, would be disqualifying.
- (4) D - Issues are major and the conduct or issue, standing alone, would be disqualifying.
- (5) E - Issues that are other matters such as, qualifications, medical issues, or inconclusive results, which may affect your determination.

c. An MFR listing all violations identified in the interview is uploaded in the Core Admin folder under “Memorandum ENTNAC Interview”. The interview process should include:

- (1) Have you ever been questioned by police, probation officer, or court official (adult or juvenile)?
- (2) Have you ever been arrested and/or FPed for any reason (adult or juvenile)?
- (3) Have you ever been told to say “no” to being questioned by police, being arrested, being issued a ticket, or ever been FPed (adult or juvenile) by any law enforcement personnel?
- (4) Have you ever been told to say “no” to having charges after you completed a diversion program, charges were expunged, removed, wiped off record, or resulted in no charges filed?
- (5) Have you ever been on probation, either supervised or unsupervised, or court probation (adult or juvenile)?
- (6) Did anyone tell you or coach you on how to respond to my questions?
- (7) Do you understand that any charge that is uncovered that was not previously disclosed may result in your fraudulent discharge?
- (8) Is there anything you feel you want or need to add to your record?

d. The interview results are included as part of any exception and includes all the charges listed by the FS including: who, what, why, where, and when details of the charges.

e. The GC or ABSM notifies the RECBN liaison and/or ship location immediately of any additional charges, not previously revealed, that return on the actual RAP sheet.

G-11. Reports, Records, and Files

Bns digitally maintain the UF 601-210.07 for each MEPS utilized. The log is maintained and filed electronically for each fiscal year and is retained for 36 months from the end of the fiscal year.

G-12. Security Interview

GCs and SIs are the last line of defense to ensure all enlistments are legal, and all enlistment information is true and accurate. The following establishes policies and details procedures for the processing of applicants for possible selection to sensitive positions and MOSs. It further establishes procedures to preclude the enlistment of disqualified

applicants.

a. Procedures:

(1) The GC will initiate UF 601-210.10 on all applicants who require a secret clearance. If the applicant answers yes to one of more of the questions (with the exception of question 10) or if the law violation answer is more than five (5) traffic offenses as defined by AR 601-210 or any offense above traffic, the SI will review the applicant's SF 86 provided by the GC and is the approval authority to continue to process for the MOS requiring a clearance. The SGC/GC is the approval authority and will sign a UF 601-210.10 with no yes answers (less question 10) or if the law violation answer is yes but the offenses are only traffic level as defined by AR 601-210 and there are five (5) or less. The SI will check the forms for completeness and accuracy. If the applicant is found acceptable, the SI will sign the UF 601-210.10. The UF 601-210.10 screening conducted by the SI is to determine the applicant's eligibility to obtain the clearance. If the applicant is determined qualified, this does not override specific MOS qualification. In cases where a UF 601-210.10 interview is requested, and the MOS is not known, the SI will conduct an interview for the clearance only. The SGC/GC will determine if the applicant is qualified for the MOS.

(2) All applicants who require a TS clearance, PRP, 09S or 09W will be interviewed by the SI either in person or via telephone by the Fort Knox PSSP detachment or the still physically assigned SI. Based on the information gathered during the interview, the SI has the authority to obtain from the DoD Central Adjudication Facility (CAF), the adjudication required to accept or reject applicants on these critical security MOSs or options. If the applicant is found acceptable for the MOS, the SI will complete all necessary security paperwork.

(3) The SI will make minor corrections to any erroneous entries, missing information or any other corrections required to the enlistment documents in Bi Zone. The SI will inform the GC that corrections have been made to the SF 86 as this could affect enlistment eligibility. In cases where correction to the applicant's record will be time consuming, processing will be discontinued until the recruiter has made the required updates. The SI will not approve any further processing until a corrected copy has been obtained from GCRc. The updated copy will be reviewed and approved by the SI.

NOTE: The SI will not perform GC functions or prepare enlistment paperwork.

b. TS Processing:

(1) Applicants who enlist for an MOS, option or assignment that requires security processing will be processed as follows:

NOTE: Permanent reservations will not be confirmed if SI approval is required and annexes will not be generated if SI review is pending.

(a) SIs will review the SF 86, certification PAI/PEI GCRc, physical and REQUEST reservation (if available). GC shops with access to a SI will refer applicant to him/her. SIs will ensure all documents are signed and printed on the current processing day and all entries are correct. GC shops without an onsite SI will call the Fort Knox PSSP detachment at 1-833-290-0109 for an interview. The SI will make a determination of acceptability or non-acceptability.

(b) Fort Knox PSSP SIs or the MEPS SI still in place will upload results of the interview and any supporting documents in ERM under Core Admin, Security Technician folder once it is completed. If the results are unable to be uploaded on the day of enlistment, at a minimum the SI will enter comments in the free form remarks block whether or not the applicant passed or failed the security screening. At no time will the DEP/DTP enlistment occur without proof that the required interview has been completed and passed.

(2) PS/GNPS (MOS qualified secret and TS); the SI will conduct the interview and terminal check. As a reminder, this action will not change any previous instructions.

(3) Screening conducted by the SI is to determine the applicant's eligibility to obtain a clearance. If the applicant is determined "qualified" this does not override specific MOS qualifications such as law violations. Certain military intelligence MOSs dictate that applicants cannot receive a charge over the minor non-traffic level. If the SA qualifies these individuals, the GC must still obtain an ETP or approval from the proponent for the MOS via workflow to EEPD Policy. The SA with assistance from the PSSP supervisor or DA are making the clearance determination only.

(4) GCRc will submit the TS clearance on the day DEP/DTP/DS. The SI will be responsible for the acceptance of the investigation in GCRc with assistance from the station if errors return from AIES. If there is information that is required for the completion of the SF 86 that does not relate to clearance information necessary for the submission. The SI should also notify the recruiter and that further information is required by XX date (a suspense date) so the submission can occur.

(5) FSs who require additional medical screening or tests such as the DLAB or any additional requirements/tests related to the MOS qualifications will not be submitted for a TS clearance until any and all results have returned and the FS maintains their MOS eligibility with either a passing score or an approved ETP. This normally will occur within the 14 day window, but there could be circumstances that dictate a delay in the

submission. If the delay in submission is going to be 30 or more days, SAs will contact their PSSP for instructions.

c. PRP screening. Applicants who enlist for a MOS, option, or assignment that requires a PRP screening will be processed as follows:

(1) GCs with access to a SI will refer the applicant to him/her or if there is no SI assigned, call 1-833-290-0109 for an interview. SIs will ensure all documents are signed and printed on the current processing day and all entries are correct. SIs will screen the SF 86 and physical to determine eligibility to continue to process for the MOS. All results will be uploaded in ERM. Approval authority for PRP MOS determinations is the Fort Knox PSSP supervisor.

(2) If approved, GCs will submit the clearance via GCRc until an acceptance is returned.

d. Ship procedures. No requirement for SI to interview any shippers. If SGC/GC determines that the FS remains qualified for the MOS IAW DA Pam 611-21, the FS will ship as schedule. (See F-1 for ship locations for applicants who do not require BCT.)

e. Additional procedures for AR. The SI will screen all AR applicants that require a security clearance. The SI will initiate a request for special background investigation (SBI) in the same manner as RA applicants with the following exceptions:

(1) Standard training program (STP). The SI will conduct an initial interview on the day the applicant contracts with the AR. If CAF, SI or the PSSP detachment determines the applicant is not eligible for clearance, he/she will be returned to the SGC for disposition and must choose a different MOS.

(2) SIs will ensure all Phase II shippers have a clearance submitted. The clearance must be in progress or finalized prior to the Phase II ship date. If the Phase II shipper has a final clearance or the investigation is still in progress the Phase II shipper can ship as scheduled, no further interview required. The SGC must be notified if the SI has an indication that the Phase II shipper has been denied a final clearance. The TPU will be contacted by the SGC or Bn Ops for shipping instructions. If the Soldier is in due process, the TPU will have to approve the shipment to training. If due process has been completed and the results is that no clearance can be granted, the TPU would have to request a different MOS through AR G1.

(3) AR PS. The SI will conduct the security interview for all PS requiring a TS and the CAF will adjudicate. As a reminder, this action will not change any previous instructions given. If the applicant requires MOS training, the SI will conduct an interview and submit clearance request if qualified.

f. MOSs and options requiring SBI, SCI, BI and secret and TS clearances. GCs and SIs will use DA Pam 611-21 to determine if the MOS or option requires a SBI, SCI, BI or secret or TS clearance.

Appendix H

Change in Active Duty Date and DEP/DTP Renegotiation

H-1. Policy

This appendix outlines procedures for recruiting personnel to apply in the FS change of active duty date and renegotiation (reno) of DEP/DTP contracts.

H-2. General

Provisions for DEP/DTP change in active duty dates and reno exist as a management tool to allow flexibility in responding to disqualifications for options and a request for extension or discharge from DEP/DTP, enlistees, requests for early ship, and other reasons authorized by appropriate authority. Changes in active duty dates and renos involve substantive changes to the enlistment contract. Process these actions to avoid invalidating the existing contract. Under normal circumstances, FSs are authorized to serve in the DEP/DTP no more than 365 days, unless exception is granted. ETPs are forwarded to EEPD Policy, via GCRc workflow.

H-3. Renegotiation Procedures

The automated enlistment annex serves as DEP/DTP orders for all NPS applicants. Therefore, the annex must document all periods of DEP/DTP service. Complete the following actions for a reno.

a. GCs reno the FS, using REQUEST renegotiate screen to obtain a new reservation. Select a new MOS and/or ship date, enter the proper cancellation code, and complete the reservation.

b. Prepare a new automated annex A (for NPS, GNPS, and PS (if applicable)). The GC and FS then sign the new annex with item 3 reflecting the new reservation.

c. Reno require completion of UF 601-210.22 (Request to Change Enlistment Options) by the applicant and approval by the appropriate authority.

FSs renoing and wanting incentives must choose incentives offered at time of original enlistment unless otherwise indicated by EEPD.

H-4. DEP/DS Renegotiation Approval Authority (RA)

Bde and Bn Cdrs are responsible for and maintain approval authority for RA renos with specific exceptions.

a. HQ, USAREC is the approval authority for the following reno requests:

- (1) Two-time reno (regardless of the reason).
- (2) Extension beyond 365 days in DEP (with exception of a 14-month HSSR).
- (3) Any ship day reno, regardless of the reason.
- (4) Medical -Temporarily Medically Disqualified (TMR) and Reevaluation Believed Justified (RBJ) for more than 180 days. A UF 601-210.22 is not required for a FS who is TMR'd or RBJ'd generate a workflow only.

b. The Bde Cdr retains approval authority for the following reno requests:

(1) Matches - FS must have an approved retain from the Bde Cdr to reno. If a FS's retain is still pending, reno is not authorized, unless the RAP sheet has returned.

- (2) Change MOS/option or Family/personal issues within 1 to 16 days from ship date.
- (3) Change in AD date (no change in MOS/option) within 1 to 16 days from ship date.
- (4) Medical - TMR/RBJ for 90-180 days.

c. The Bn Cdr retains the approval authority for the following reno requests:

- (1) Minor non-traffic charges and misdemeanor charges when the final disposition is resolved within 30 days.
- (2) Change MOS/option or Family/personal issues outside of 16 days from ship date.
- (3) Change in AD date no change in MOS/option outside 16 days from ship date.
- (4) Medical-TMR/RBJ for 1 to 89 days.

d. Renos are not authorized for serious criminal misconduct charge.

e. A workflow is generated for all renos. The workflow includes renos that EEPD forwards to HQ DA for exception. Direct contact with HQ DA is not authorized below EEPD. GCRc automatically enters the reno workflow identification numbers on page 4 of the DD 1966.

f. Contact the ROC for changes of AD date or reno for PS/GNPS.

g. FSs who have a chance to complete high school by attending a summer session to make up the graduation requirements would be acceptable. Renos are authorized only in cases where the FSs are enrolled in a tier 1, traditional high school (12L) completion course. High school letter must be from the high school the FS is attending. High school telephonic enrollment letter is not authorized to be used for reno purposes.

H-5. DTP Renegotiation Approval Authority (AR)

a. Process an AR renos workflow in GCRc by:

(1) Submit all renos to USAREC via GCRc workflow for review. These include:

- (a) Change in MOS/TPU.
- (b) Three-time renos regardless of the reason.
- (c) Standard Training Program (STP) to Alternate Training Program (ATP) or ATP to STP when an MOS or TPU change.
- (d) Change in MOS or TPU due to deactivation or reorganization (with orders).
- (e) Change in training date beyond 365 days in the DTP.
- (f) Ship date change.
- (g) Two-time reno.
- (h) To complete education requirements (to ship within 365 days in DTP).
- (i) Medical (including overweight/underweight).
- (j) ATP to STP (same MOS and TPU) Matches - when additional time is required for disposition.
- (k) Conduct/Legal - when additional time is required for disposition.

(2) Required documents for these actions include: MFR from TPU requesting approval or disapproval for retaining the FS for all renos (except medical); updated DD 2808, DD 2807-1, 680-ADP, and any supporting medical documents; FS statement that outlines the circumstances (if applicable) of the charge/match with expected release/completion dates and acknowledgment that incentives may change based on the reno.

(3) Required documents for a change in MOS/TPU, STP to ATP, or training date beyond 365 days in the DTP for capture and upload in ERM are:

(a) TPU endorsement MFR. For MOS or option changes the MFR must include the new position, paragraph, line number(s), and unit identification code (UIC).

(b) The statement from the FS, outlining the circumstances for the chance and an acknowledgement that the incentives may change based on the reno action.

(c) TPU deactivation or reorganization orders, if applicable.

(d) UF 601-210.22 (Request to Change Enlistment Option).

- (e) Any other supporting documents as required.

H-6. Remote Renegotiation

a. FSs with approved reno requests aren't required to travel to a MEPs to accomplish the reno if they are in a location below:

(1) Las Vegas Company: FSs from Las Vegas Company will be transported to the Las Vegas Company GC located at the 6th Bde HQs.

(2) Honolulu Company: FSs who do not reside on Oahu or enlisted as a result of an overseas DEP trip can reno telephonically. After receipt of an approved reno request recruiters/station commanders must establish a three-way call between the GC, ROC and the recruiter/station commander.

(3) Guam Detachment: FSs who enlisted as a result of an overseas DEP trip are authorized to reno telephonically. After receipt of an approved reno request V7 personnel assigned to Guam are authorized to reno the FS with the recruiter/station commander. If assistance by the ROC is required a three-way call will be established.

b. A new reservation letter will be emailed to the recruiter/station commander to provide to the FS. Annexes and updates to the enlistment agreement will be finalized during DEP out procedures at the MEPS on ship day.

H-7. REQUEST Renegotiation Codes

The following is a list of REQUEST renegotiation codes:

- a. AS - Contract renegotiated after ship (liaison use only)
- b. CM - Changed MOS
- c. CO - Changed option
- d. CR - Changed reception station
- e. ED - Continuing education
- f. EE - Erroneous enlistment (GC error)
- g. EN - Background investigation failure
- h. FG - Failed to graduate high school
- i. HP - Hardship (personal)
- j. OD - Failed to achieve minimum OPAT score for MOS
- k. OF - Failed to achieve minimum OPAT score
- l. OP - Exceeded current MOS OPAT requirement
- m. TM - Temporary medical disqualification
- n. UI - Unqualified/Ineligible (ROC use ONLY)
- o. WS - Weight standard

Appendix I

Active and Reserve Component Separations

I-1. Purpose

This appendix outlines procedures for processing DEP/DTP/DS separations after the initial Oath of Enlistment.

I-2. General

Requests for separation from the DEP/DTP/DS are approved for valid reasons identified in AR 601-210 and AR 135-178. Reasons for granting FS separations and approving authorities are provided at Tables I-1 and I-2. b.

Separations fall into three categories:

- a. The result of a request from a member of the DEP/DTP/DS
- b. The discovery of an erroneous or fraudulent enlistment
- c. Medical disqualifications

I-3. Routing of Separation Requests

- a. The request for a FS initiated separation must bear the signature of the FS who initiated the request.
- b. Recruiting personnel must respond positively to any inquiry from FSs concerning separations from the DEP/DTP/DS. Under no circumstances will any member of this command threaten, coerce, manipulate, or intimidate FSs, nor may they obstruct separation requests.
- c. Submit FSs UF 601-210.21 (Separation Request) with supporting documents through the chain of command.
- d. Bn Cdrs may approve requests within their authority and publish appropriate separation orders.

I-4. Separation Procedures

a. Process FS separation by:

(1) FS initiate separation request on UF 601-210.21 and must be signed by the FS. If the FS is unavailable or refuses to sign, write "unavailable for signature" or "refuses to sign" in the remarks section of the form. For medically disqualified FSs, the CMO must annotate the DD 2808 with the disqualification which will be uploaded in ERM by the SGC/GC, a UF 601-210.21 is not required for a FS who is medically disqualified by the CMO.

(2) Bn Ops or GCs will cancel the reservation with the correct code. When the FS is medically disqualified, cancel the reservation as soon as possible to mitigate losses of training base reservations inside of 30 days.

(3) Bn Ops will publish appropriate separation orders within 14 days. Upload UF 601-210.21, REQUEST cancellation printout, supporting documents, and the discharge orders in the "DEP Admin" folder in ERM.

(4) A workflow is generated as a result of the discharge being approved. GCs will provide the discharge orders and medical records to the MEPS Ops who will remove the record from MIRS.

(5) GCs will verify the record is removed within 14 days from date of discharge orders in MIRS by obtaining an updated 680-3ADP verifying the discharge data is correct and upload the 680-3ADP in ERM. If errors are discovered, report them to the respective MEPS for corrections.

b. For FSs who enlist into the DS and fail to enter the RA on scheduled ship date:

(1) No separation orders are published for DS. The GC shop completes the UF 601-210.21, and cancels the REQUEST reservation on the same day.

(2) For FSs who enlisted on a DD 368. Complete the remainder of the DD 368 for forwarding to the Service with additional information for distribution as per below.

(a) Enter the cancellation code (see Para I-9) in the space provided; Section III (#7).

(b) Complete Section III (#8).

(c) Complete the remarks block to explain the reason for the cancellation; Section IV.

(3) The REQUEST cancellation printout, completed DD 368, and UF 601-210.21 for Soldiers in the RA DS are captured and uploaded in the "DEP Admin" folder in ERM. Copies are provided to the following:

(a) Individual

(b) Unit (applies to serving members of any RC)

(4) Soldiers of the IRR, Inactive National Guard (ING), or other Services (non-unit members), and those with no MSO, distribute as outlined in (4) above, less the unit. The UF 601-210.21 is uploaded in the "DEP Admin" folder in ERM.

(5) For reasons of death, explanation on UF 601-210.21 is sufficient. Check the "Death" block and in the remarks section, enter "Member Deceased".

(6) For DS with a positive HIV results the UF 601-210.21 only reflects "medical" in the Remarks.

(7) The Bn Ops monitors DEP/DTP/DS losses in RMZ, under the FS Loss tab to ensure accountability and proper coding for all losses in GCRc.

c. When a FS enlists into DEP/DTP, the DD 4 series is valid until discharge orders are published and signed by the Bn Cdr. The Bn publishes the discharge order within 14 days of the cancellation of the reservation.

d. The following procedures comply with AR 135-178 when processing a FS separation:

(1) When the AR FS requests separation by signing a UF 601-210.21, the notification process identified in AR 135-178 is considered to have been completed.

(2) When the AR FS's DAT or HIV test is returned positive, the letter of notification issued by CMO is considered to comply with the notification process contained in AR 601-210, chapter 5-78 for DAT and AR 600-110 (Identification, Surveillance, and Administration of Personnel Infected with HIV) for HIV.

I-5. Procedures for Separation from the RA after the Oath of Enlistment

a. Each case will be reviewed by HQ USAREC. Bn Ops will forward an ETP to EEPD Policy through the chain of chain of command via workflow.

b. Separation from the RA as a result of the discovery of a disqualification (erroneous enlistments) after the Oath of Enlistment, but prior to the FS's shipment (departure from the MEPS) the enlistment will be voided as follows:

(1) After GC reports the disqualification to MEPS, the MEPS Cdr will revoke any orders already issued assigning the individual to a Reception Battalion (RECBN) or other unit of assignment and will issue an order assigning the individual to the respective recruiting Bn for the purpose of separation. The REQUEST reservation is not cancelled and the record is "Shipped confirmed" in REQUEST.

NOTE: This is only authorized on the day of accession. After the day of accession, MEPCOM does not have authority to revoke orders or change PULHES.

(2) The recruiting Bn Cdr will void the enlistment by issuing an order (AR 600-8-105) releasing the individual

from the custody and control of the Army. The order will reflect that the individual's enlistment is void by reason of erroneous enlistment and that his/her release from the custody and control of the Army is being accomplished by reason of a void enlistment.

NOTE: If the FS absents themselves from the MEPS without authority prior to ship or fails to appear for the departure of the FS's transportation, the MEPS notifies the ship GC, who notifies EEPD ROC immediately. The ROC will notify the respective RECBN and the EEPD PS/Liaison Branch Chief. The initiation of separation, if appropriate, is a function of the initial receiving activity or RECBN and is not the responsibility of MEPS or the recruiting Bn. The individuals have accessed into the Army and are not assigned to the respective recruiting Bn for separation.

I-6. Positive Drug Test Separation

Process all FSs with confirmed positive drug test (DAT) results as follows:

- a. GC cancels the REQUEST reservation on the same day the notification is received in GCRC.
 - (1) Positive for THC (marijuana), use cancellation code PT.
 - (2) Positive for amphetamines, or both THC and amphetamines, use cancellation code PB.
 - (3) Positive for cocaine, or both THC and cocaine, use cancellation code PC.
 - (4) Positive for opiates or both THC and opiates, use cancellation code PO.
- b. UF 601-210.21 is not required for the above cancellations with the exception of DS FSs.
- c. PS FSs do not require discharge by the Bn. However, notification of positive DAT is required, and cancellation of the reservation is mandatory.
- d. Upload DAT notification MFRs from the CMO in the "DEP Admin" folder in ERM.
- e. Publish and upload all positive drug test separation orders in ERM within 14 days of cancellation.
- f. Cancel reservations for AR FSs with confirmed positive drug results using the "full" cancellation process and notify the gaining unit.
 - (1) The GC informs Bn Ops upon notification of a DAT result for AR FSs and cancels the REQUEST reservation on the same day notification is received.
 - (2) An MFR from the Bn notifying the TPU Cdr of the positive drug test is required. Upload all notification MFRs in the "DEP Admin" folder in ERM.

I-7. Failure to Report

- a. For RA-If the FS simply fails to report; cannot be located, declares a refusal to enlist in the RA, reports for AD but declines enlistment in the RA and does not formally request separation; and there are no extenuating circumstances, the Bn Ops reviews the enlistment record to ensure that all required documents are present, properly prepared, signed, dated, and witnessed, as appropriate. The reservation is cancelled and the individual is discharged (as required).
- b. For USAR-USAREC Liaison will provide email of process for BN OPS and SGC to follow:

I-8. Requests for FS loss forgiveness for DEP/DTP/DS

Requests for FS loss forgiveness will be considered in the following cases. The approval authority is the Bn Cdr with documentation verifying any of the below statuses:

- a. DT - Death
- b. PH - HIV positive
- c. OT - Member of RC who has been mobilized or called to AD
- d. A verified contract of an ROTC scholarship recipient, acceptance to one of the US Military Academies (West Point, Naval, Coast Guard, Air Force) or acceptance to one of the Academy Preparatory Schools.

I-9. REQUEST Cancellation Codes

a. The following is a list of REQUEST FS loss cancellation codes for RA and AR (AR only codes in I-9c below):

- (1) CE - Civilian employment
- (2) DE - Declining enlistment (RA)
- (3) DT - Death
- (4) ED - Continuing education
- (5) FE - Fraudulent enlistment
- (6) FG - Fail to graduate high school
- (7) HP - Hardship
- (8) ND - No DEP loss (same-day cancellation). Only used for cancellation on applicants that have not been

confirmed or that do not result in a loss. Do not use the code in conjunction with a reno.

(9) NP - Background Investigation Failure.

(10) NS - No-show (used only when the FS fails to arrive at the MEPS on ship day).

(11) OT - Other (code only used for FSs who are in the RC and are ordered to AD). GC must list the reason in the remarks section.

(12) PA-Positive alcohol test

(13) PB-Positive amphetamine test

(14) PC-Positive cocaine test

(15) PG-Pregnancy (only when validated by CMO or by FS's personal physician).

(16) PH-Positive HIV

(17) PM-Permanent medical disqualification

(18) PO-Positive Opiates

(19) PR-Police record (open law violation(s) or new law violation(s) since enlistment that disqualified FS). GC must use the FE code if information was concealed.

(20) PT - Positive THC test

(21) WS - Weight standards

(22) OPAT Codes:

(a) OF - Failed to achieve minimum OPAT score.

(b) OD - Failed to achieve minimum OPAT score for MOS.

(c) OR - FS refused to take OPAT.

NOTE: The Company Cdr will verify the reason(s) for the loss in an MFR in cases where official documents validating the loss do not exist or cannot be obtained.

b. A short narrative in the remarks section is required for clarification when the code itself does not fully explain the circumstances. The use of "apathy" is not authorized.

c. The following is a list of authorized REQUEST codes that only apply to AR DTP:

(1) DS - Declined to ship (used when the applicant arrives at MEPS to ship and refuses or for AR loss where the reason for the cancellation does not match any other authorized DTP loss code. The Company Cdr must sign the UF 601-210.21 in these cases).

(2) JC - Joined another component (DD 368 required).

(3) RS - Contract with an ROTC program for purposes of commission or contract as an ROTC SMP.

d. Prohibited cancellation codes: CA, CS, DA, DP, FC, JO, ML, TD, TI, TS, UR, and US.

e. No loss cancellation codes:

(1) TR - Temporary reservation (the only cancellation code available for temporary reservations).

(2) ND - Same day cancellation, no loss. Never use this code after swear-in, even if it is a cancellation on the same day.

I-10. FS Separation Documentation and Void Enlistment Processing and Disposition

a. The respective Bn executes all requests for void enlistments. The Bn Cdr is the approval authority on all discharge orders for fraudulent enlistments.

b. When processing the following requests for FS separation, a Bn MFR that details the reasons for separation, a commissioned officer or senior NCO (E8 or above) interview of the FS, UF 601-210.21 and the DD 4/1 are required. Additional documents include:

(1) Concealed conduct

(2) ENSQ, page 7 (and page 9 if continued)

(3) Copy of Entrance National Agency Check, DD 369, UF 601-210.02, or court documents proving fraud.

(4) Concealed dependency

(a) DD 1966, page 1

(b) ENSQ SF 86, page 5

(c) Dependency documents proving fraud

(5) Concealed PS

(a) DD 1966, page 1

(b) ENSQ, page 6

(c) Documentation of PS proving fraud

(6) Concealed medical: Copy of DD 2807-1 and DD 2808

c. Listed at table I-1 are the basis for separation and the documentation required before separating a FS. Copies of the documents are acceptable.

d. Death of a FS. The death of a FS requires the Bn Ops and the SGC to take certain actions. A copy of the

death certificate is provided to the SGC, who forwards the document to the MEPS Cdr. If the death occurred while participating in a military sanctioned event (IAW AR 638-8, chapter 2-6) the unit immediately contacts the Casualty Assistance Center.

I-11. Army Reserve Entry Level Separations

a. Initiate Entry Level Separations (ELS) on all Soldiers who fail to ship to IADT - (conduct, administrative or medical). This includes Soldiers who receive a temporary disqualification lasting six months or more.

b. If the Soldier ships to IADT, it is the AR TPU unit's responsibility to initiate the ELS.

c. If the Soldier never ships to IADT, it is USAREC's responsibility to initiate the ELS. A USAREC initiated ELS does not require a TPU Cdr's memo.

d. A full cancellation is completed in REQUEST and a discharge order completed at the respective BN. An AR FS who desires to enlist AD is not discharged as ELS and must submit a DD 368 through their chain of command to the proper discharge authority IAW current AR release policy and F-10 of this regulation. AR ELS Soldiers are not authorized to re-contract for RA or AR until six (6) months after the effective date of the discharge order. Follow these procedures:

(1) Station commander, or designated representative, will:

(a) Immediately initiate UF 601-210.21.

(b) Forward completed UF 601-210.21 to the Company Cdr for review and signature.

(2) The Company Cdr will:

(a) Immediately confirm annotation of the reason for separation on the UF 601-210.21.

(b) Sign, date and forward UF 601-210.21 to the Bn Cdr for review and signature.

(3) SGC/G C will:

(a) Upon receipt of UF 601-210.21 from Bn Ops, verify the correct cancellation code/reason for separation.

(b) Sign and upload UF 601-210.21 in FS's ERM.

(c) Cancel REQUEST reservation using the correct cancellation code.

(d) Provide MEPS with ELS orders and the medical folder.

(4) Bn Ops will:

(a) Ensure that UF 601-210.21 is completed with appropriate signatures and the correct cancellation code for separation. If the FS is not available, or refuses to sign, indicate this by writing "refuses to sign" or "unavailable for signature" in the Remarks section. Forward the completed UF 601-210.21 to the SGC/GC.

(b) Validate that the Soldier is NPS and he or she did not ship for training.

(c) Verify REQUEST reservation cancellation code.

(d) Create and process AR ELS using Order Format 500 found at:

(<http://span.usarec.army.mil/sites/HQ/G3/EEPD/SitePages/Policy.aspx>) under AR Resources. The effective date of the ELS order is the first day of the following month.

(e) Upload the signed ELS order in ERM under "DEP ADMIN" folder as a discharge order.

(f) Forward a copy of the ELS order to respective MEPS for processing.

(g) Provide a copy of the ELS order to the TPU for input of the loss transaction through Regional Level Application Software (RLAS).

NOTE: AR ELS Soldiers cannot re-contract for the RA or AR until six (6) months after the effective date of the discharge order. ELS Soldiers re-contract IAW current waiver guidelines. EEPD Policy reviews ETPs for RA enlistment prior to the end of the six (6) month waiting period on a case by case basis. If a PS does not ship to BCT for the AR a Unit letter will be obtained from unit requesting to cancel training seat with the understanding that they will have to discharge the Soldier. Then an ETP will be requested from HQ USAREC for training seat only cancellation and then cancellation will be sent to unit to assist with the discharge. ELS orders will not be cut by USAREC personnel.

I-12. Order Format and Responsibilities

The Bn issues Separation Orders, Orders format 500 for RA FSs who do not enlist from the DEP and for AR FSs who do not ship. Orders format 505 (Release Order) to separate RA FSs for erroneous and/or fraudulent (withheld disqualifications that existed prior to entry into the DEP) reasons. Forward these cases to the Bn Cdr for final determination and signature (see Table I-4 for the orders formats). Battalion commander will sign discharge orders and will not delegate to others to sign

Table I-1-Basis for Separation and required documentation

Basis for separation	Required documentation
Medical disqualification to include, drug addiction, alcoholism, pregnancy, and positive HIV.	Original or MEPS certified copy DD 2807-1, DD 2808, and SF 513 (Medical Record - Consultation Sheet) (if applicable), and any other medical documents bearing on the disqualification. Original or MEPS certified copy of DD 2807-1, DD 2808, and statement from a physician giving estimated date of birth. NOTE: DD 2808, items 74-78, should be annotated as appropriate by the MEPS CMO.
Conduct disqualification	DD 369, UF 601-210.02, UF 601-210.04, or (if appropriate) Entrance National Agency Check; approved waiver if waiver was processed; and all other data bearing on conduct disqualification. NOTE: If the FS has been convicted and sentenced for offense committed after they enlisted, include details of offense and place of confinement.
Hardship	Statement from FS, family member, doctor, clergy, etc. Any statement substantiating that hardship exists.
Dependency	Documents substantiating dependency (that is, birth certificate, marriage certificate, etc.).
Erroneous, defective enlistment, or fraudulent enlistment.	Show that such enlistment occurred. Senior NCO (E8 or above) or commissioned officer interview required. If completed, copy of commander's inquiry or report of investigation, if applicable.
Acceptance of scholarship or pursuit of higher education	Signed statement from the FS requesting separation (UF 601210.21 can be used), and letter of acceptance from institution indicating award of scholarship, grant or enrollment into program.
Conscientious objector	Statement from the FS.

Table I-1 Basis for separation and required documentation

Table I-1 (Con't), Basis for separation and required documentation

Religious training or appointment as an ordained minister.	Statement from appropriate authority of the church, religious sect, or organization that the FS has met the requirements for recognition, and has been appointed a regular or duly ordained minister of religion; or that he or she must be separated from military status for further processing into the order, is fully qualified and acceptable for further religious training or that, if separated will be eligible for ordination and will take final vows on or about a given date. Signed statement from FS requesting separation.
Acceptance of an appointment as a commissioned or warrant officer in a branch of the service or as a commissioned officer of the Public Health service or Environmental Science Service Administration.	Evidence of appointment and signed statement from FS requesting separation.
Failure of senior to graduate.	Letter from high school confirming that FS has dropped out of school or telephonic verification.

Determined no longer qualified for option for which enlisted in the DEP/DTP and declines alternate.	Signed statement from FS requesting separation. Statement from GC verifying loss of original option.
Enlistment into another service.	Statement from FS with evidence of enlistment intention from another service.
Personal problems.	Signed statement from the FS, or third party verifying the personal problem or issue to support request.
Marriage	Marriage certificate.
Concealment of PS	Copy of DD 214 (Certificate of Release or Discharge From Active Duty) or DD 215 (Correction to DD 214 Certificate of Release or Discharge From Active Duty).
Recruiting error or enlistment.	Statement from GC explaining the error.
Other	Minimum documentation as required and any documentation to support the request. Entire ERB along with one copy of the death certificate.
	Notification of death will be reported to HRC by Bn Cdr. Separation order will not be issued. NOTE: Death certificate must be sent. Other documentation to verify death will be accepted if extenuating circumstances exist, as determined by HQ USAREC, G3, Waivers Branch.

Table I-1 (Con't), Basis for separation and required documentation

Table I-2 Authorities for approval and/or disapproval of DEP/DTP separation requests

Approval authority	Basis for separation	Disapproval authority
Bn	Medical disqualification or psychiatric disorder	CG USAREC
Bn	Marriage	CG USAREC
Bn	Pregnancy	CG USAREC
Bn	Conduct disqualification	CG USAREC
Bn	Hardship	CG USAREC
Bn	Dependency	CG USAREC
Bn	Acceptance of scholarship or pursuit of higher education (education above high school level).	CG USAREC
Bn	Enrolled in training to become or receive appointment as an ordained minister	CG USAREC
Bn	Acceptance of appointment as a commissioned or warrant officer in a branch of the service or as a commissioned officer of the Public Health Service or Environmental Science Service Administration.	CG USAREC
Bn	Failure of senior to graduate and does not meet basic enlistment criteria of non-high school graduate.	CG USAREC
Bn	Determined no longer qualified for option for which enlisted in the DEP/DTP.	CG USAREC
Bn	Enlistment in another service.	CG USAREC
Bn	Loss of original option and/or military occupational specialty resulting from temporary disqualification for enlistment and declines alternate.	CG USAREC
Bn	All other reasons for the convenience of the Government (for example, personal problems, conscientious objector, no background investigation, aliens).	CG USAREC
Bn	Erroneous enlistment. Provisions of chapter 7.3 apply. (Written statement of interview is required to determine if disqualifying information was withheld, either intentionally or unintentionally.)	CG USAREC
Bn	*Fraudulent enlistment (AR 135-178). (Interview is required to determine if Soldier intentionally concealed disqualifying information.)	CG USAREC
CG USAREC	In DEP/DTP 365 days. Maximum time in DEP/DTP is 365 days. This period is established by Congress. FSs are not permitted to remain in the DEP beyond 365 days. All violators to this rule must justify, in writing, why the individual was retained beyond the limit.	CG USAREC
Bn	Overweight or underweight.	CG USAREC

Table I-2 (Con't)-Authorities for approval and/or disapproval of DEP/DTP separation requests

Table I -3 Separation authority

Basis for separation	Separation code	Authority
Medical Disqualification-EPTS	ZAA	AR 135-178, paragraph 14-5
Medical Disqualification-NEPTS	ZAB	AR 135-178, paragraph 14-5
Medical Disqualification-Pre-accession Drug, Alcohol Testing	ZZY	AR 601-210, chapter 4-18
Pregnancy	ZAC	AR 135-178, paragraph 14-5
Death	ZAD	AR 135-178, paragraph 14-5
Conduct Disqualification-EPTS	ZBA	AR 135-178, paragraph 14-5
Conduct Disqualification-NEPTS	ZBB	AR 135-178, paragraph 14-5
Apathy/Personal Problem	ZBC	AR 135-178, paragraph 14-5
Refuse to Enlist	ZBD	AR 135-178, paragraph 14-5
Did Not Report on Date Scheduled	ZBE	AR 135-178, paragraph 14-5
Concealment of PS	ZBF	AR 135-178, paragraph 14-5
Dependency Disqualification	ZCA	AR 135-178, paragraph 14-5
Marriage	ZCB	AR 135-178, paragraph 14-5
Personal Hardship	ZCC	AR 135-178, paragraph 14-5
Failure to graduate from High School	ZDA	AR 135-178, paragraph 14-5
Pursuit of Higher Education	ZDB	AR 135-178, paragraph 14-5
Religious Training or Appointment as an Ordained minister	ZDC	AR 135-178, paragraph 14-5
Ringer	ZDD	AR 135-178, paragraph 14-5
For USAREC use only	ZDE	AR 135-178, paragraph 14-5
Enlisted in Another Service	ZEA	AR 135-178, paragraph 14-5
Enlisted in Error	ZEB	AR 135-178, paragraph 14-5
Enlistment Misunderstanding	ZEC	AR 135-178, paragraph 14-5
No Longer Qualified for Option and Declines Alternate	ZED	AR 135-178, paragraph 14-5
Other Reason	ZFA	AR 135-178, paragraph 14-5
Transfer to Individual Ready Reserve (Requires USAREC Approval)	ZKC	AR 135-178, paragraph 14-5
For Official Use Only (United States Military Entrance Processing Command (USMEPCOM))	ZZZ	AR 135-178, paragraph 14-5

Table I -3 Separation authority

NOTE: EPTS = disqualification(s) existed before the FS enlisted in DEP or DTP. NEPTS = disqualification(s) occurred after the FS enlisted in DEP or DTP. (See table I-2).

Table I-4 Separation Order Formats Overview

Order and Format	Authority to Publish	Remarks
Separation (500)	Bn Cdr	
Release (505)	Bn Cdr (review by HQ USAREC)	Order Format 505 is for cases involving erroneous and/or fraudulent entry in the DEP. Cases must include written officer or senior NCO interview to determine recruiter involvement as outlined in chapter 7.3
Release from RA (505) (see fig E-5)	Bn Cdr	When Soldier has sworn in on AD and disqualifying information is revealed prior to leaving the MEPS.

Table I-4 Separation Order Formats Overview

Appendix J Army Reserve Specific Processing

J-1. Purpose

This appendix outlines policies and detailed procedures to ensure applicants are properly processed for enlistment, shipped to IADT, and separated from the AR. (Refer to Figure J-1.)

J-2. Alternate Training Program Enlistment Procedures

a. The Alternate Training Program (ATP) is designed to provide specific applicants the ability to enlist and attend IADT without interfering with civilian education or employment. In order to qualify for ATP, an applicant must be: a current High School student (CIHS/109); a High School Senior (11S) who has been accepted to college; enrolled college student; or a seasonal employee.

(1) The AR uses Advanced Initial Training (AIT) course length and MOS density to determine MOS availability.

(2) Due to AIT course length limitations, vacancies requiring and ASI are not eligible for the ATP, with the exception of band (MOS 42R).

(3) GCs are reminded that applicants enlisting for the ATP must have a Mandatory Return Date (MRD) 11 weeks from the applicant's Reception Station (RECSTA) arrival date, not the ship date. The MRD must be on the Soldier's MEPS orders.

(4) HS juniors and college students will ship no earlier than (NET) seven (7) days from the completion of the current school year. HS seniors ship NET 14 days after graduation to allow time for receipt of the HS diploma or official transcript.

(5) CIHS education verification

(a) For CIHS the verification must state the following:

1. The end date of the junior year

2. The beginning and end date of the senior year

3. The expected HS graduation date

4. Confirmation from a school official that the school is aware that the student may leave their junior year XX days early and/or return after the beginning of the senior year XX days late and will not be penalized due to military training. Confirmation must also include the number of days the student may miss and must state the specific date that the student is released their junior year to attend training.

(b) Verification may be obtained from the applicant's principal, registrar, school guidance counselor, or the custodian of records. Verification must include all items in (5) above.

(c) A signed letter (not telephonic conversation or confirmation) from the parents or legal guardian acknowledging that they are aware that their child may leave their junior year XX days early and/or return after the beginning of their senior year XX days late. The letter must specify the number of school days either at the end of the junior year or beginning of the senior year that they will allow their child to miss for military training.

(d) A telephonic verification can be performed by the ISG, Company Cdr, senior Ops, SGC, commissioned officer, ESS, or equivalent contracted personnel assigned to USAREC. The telephonic education verification must include all items in (5) above and name of applicant, last four of applicant's SSN, date of birth, name, address and telephone number of school, name and title of individual providing verification and the name and title of individual conducting verification.

b. Ship without Advanced Reservation (SWAR). GCs must pull Phase II (AIT) reservations for Soldiers who have completed Phase I (BCT) of the ATP.

(1) Do not make Phase II (AIT) reservations without verification of BCT graduation on the DD 220, or if there is a BCT completion date for the Soldier on the SWAR Report in REQUEST. ATTRS is an authorized method to verify BCT graduation. All Phase II Soldiers must ship to AIT within 365 days of BCT completion. Forward any ETPs to EEPD Policy through the chain of command via GCRc workflow to the AR G-1. Do not schedule Phase II until approval is received.

(2) Soldiers who receive an ETP to meet MOS qualifications IAW DA Pam 611-21 for the Phase I reservation, must meet MOS qualifications before the Phase II reservation is made (i.e., driver's license, typing, etc.). This does not apply to previously approved line score exceptions.

(3) When the Phase II reservation is made, the GC requests travel orders from MEPS. Upon receipt, the GC uploads the order in ERM and notifies the station of the Soldier's ship date. A copy of the Phase II reservation and order is provided to the Soldier and unit by the station. The station coordinates with the TPU to secure the Phase II packet consisting of: 201 file (to include DD 220), security clearance documentation, training records, equipment operator's qualification information, medical/dental records, DA 705, clothing record, and promotion documents.

Phase II Soldiers ship IAW appendix J-4.

(4) Soldiers identified as no longer needing a Phase II training seat are removed from the SWAR report by using the proper codes through REQUEST. Code:

- (a) A-Joined ROTC/SMP
- (b) B-Unit Discharge
- (c) C-Deceased
- (d) D-Enlisted Active Component
- (e) H-TRADOC Discharge
- (f) M-N/A-Reservation made outside REQUEST

(5) The following codes will be used to update the SWAR for Soldiers who are not attending Phase II but need to remain on the SWAR:

- (a) I-Other
- (b) J-Awaiting Training
- (c) K-Medical Hold
- (d) L-Hold other than Medical

(6) In all cases where a Soldier is not attending Phase II, proper documentation is uploaded in ERM to support the non-attendance code. The GC will place appropriate comments in the remarks section of the SWAR with an explanation for no reservation.

(7) The Soldier MUST have their full initial issue when shipping to the training base.

(8) It is the responsibility of the Bn Ops to maintain and update the SWAR Program.

NOTE: The AR G-1 memo states whether or not BCT was completed in the event the Soldier was a REFRAD (Release from Active Duty). If the Soldier has a DD 220 conflicting with the AR G-1 memo, AR G-1 makes the final decision.

J-3. Processing AR applicants with English as a Second Language (ESL)

a. Due to the extended training time for ESL plus BCT, the GC must ensure that ATP applicants have a MRD allowing for both. Those scoring 75 or above on the English Comprehension Level Test (ECLT), ESL training is not required. Applicants scoring below 75 must conduct ESL training prior to BCT, IAW Table K-1. **NOTE:** CIHS applicants are not eligible for enlistment if they require ESL training.

b. Ensure all applicants requiring ESL are shipped to Fort Sill, OK, with records marked "ESL" in red on the outer envelope.

NOTE: See K-6 for Foreign Language Recruiting Initiative (FLRI) AR processing.

J-4. AR Vacancies

a. Vacancy loads are a tool that provides USAREC some flexibility for enlisting applicants, but should not be considered standard process. Station commanders and recruiters will attempt to fill available, advertised vacancies first. When a vacancy load is submitted, BN Ops will ensure the load is not over strength filling unit "A" when unit "B" is under strength in the same MOS.

b. BN Ops will have access to the Reserve Components Manpower System (RCMS) with access to the Unit Explorer and Request Unit Transcript functions. The Request Unit Transcript function allows personnel to view current assigned strengths and vacancies for the TPU in question.

(a) RMCS is located at: <https://rcms.usar.army.mil/>

(b) Instructions for accessing and requesting access to RCMS can be found on the EEPD Span site at: https://span.usarec.army.mil/sites/HQ/G3/EEPD/Shared%20Documents/Systems_Info/Requesting_RCMS_Access.pdf

c. Under no circumstances can an applicant enlist into any TPU that has a Priority Code of 70 and above. The Priority Code is found by running a "UNIT" report in REQUEST.

d. Letters of Acceptance (LOA) are not required for most vacancy loads. When an LOA is required, it must be signed by the TPU Cdr. or authorized representative. The signature authority or assumption of command order must accompany the LOA. When the vacancy load will be placing more than two Soldiers in the position, the LOA must state that the TPU Cdr is aware that the position will be (triple, quadruple, etc.) slotted. An example LOA can be found on the EEPD-Policy SharePoint at:

<https://span.usarec.army.mil/sites/HQ/G3/EEPD/SitePages/Policy.aspx>

(1) For 09R Enlistments: Simultaneous Membership Program (SMP) Potential applicants require the letter of intent from the Professor of Military Science (PMS). SMP Participants require the CC Form 203-R or the CC Form 167-R and the DA Form 597.

e. The Vacancy Load Request can be found on the EEPD-Policy SharePoint. When required, the LOA will accompany the Vacancy Load Request form when submitted for processing.

Vacancy load processing procedures:

f. Due to approval requirements outside of USAREC control for certain UICs and MOSs, all Vacancy Load Requests will be submitted a minimum of three (3) duty days prior to the projected floor date.

g. When required, the LOA will be uploaded to ERM. Vacancy Load Request form and the LOA (when required) will be emailed to BN Ops for validation.

h. BN Ops will check validate that the UIC, POS, PARA, LIN, and MOS are valid in RCMS. Request with errors will be returned without action (RWA). If there is a currently advertised vacancy for that MOS in a different UIC, the Bn Ops will identify the reason for requesting the Vacancy Load. If quantifiable evidence does not support proceeding with the Vacancy Load Request, it will be RWA'd and the applicant enlisted into the currently advertised position. If the Vacancy Load Request data is correct, it will be submitted by email to the AR Liaison and AR ROC NCOs using the email distribution list: USARMY Ft Knox USAREC List HQ G3 Vacancy Load usarmy.knox.usarec.list.hq-g3-vacancy-load@mail.mil.

i. To ensure timely processing and facilitate tracking of Vacancy Load Requests, the email subject line will be formatted as follows:

(a) Subject Line: Vacancy Load Request RSID Applicants Last Name Floor Date

(b) Subject Line Example: Vacancy Load Request, 8B6D_Johnson_20180101

(c) No other information is required in the body of the email. All data will be pulled from the LOA and

Vacancy Load Request form.

j. The following MOSs require a Vacancy Load Request submission:

(a) 09C - must have UIC, Para 101, Line 01, Pos 9990

(b) 09N - UIC W0NJAA, Para 001, Pos 01, Pos 0005

(c) 09R - must have UIC, Para 101, Line 01, Pos 9991

(d) 09Q - UIC W47A9Q, Para 000, Line 00, Pos 9992

k. The following AOCs are authorized for 09S enlistments without additional authorization:

(a) 12 Engineer

(b) 25 Signal

(c) 31 Military Police

(d) 42 Adjutant General

(e) 36/44 Finance

(f) 74 Chemical

(g) 88 Transportation

(h) 89 Ammunition

(i) 91 Ordnance

(j) 92 Quartermaster

l. The vacancy requests listed below require AR G1/G7 approval and require additional processing time.

(a) All E8/E9 vacancy request

(b) All Will-Train flips to 'Yes', to include 00G MOS

(c) CMF 68 series MOSs require AR MEDCOM approval to be changed from Will-Train "No" to Will-Train "P".

m. MI AOCs; 35, 37 and 38 vacancies are limited. OCS applicants applying for MI unit AOCs must have an approved ETP from AR G1 prior to accession. A LOA from the TPU Co. must accompany all requests for these AOCs. Recruiters will ensure that MI OCS applicants are aware that accession into a MI AOC is not guaranteed until the ETP is approved. Once the OCS applicant has been boarded and approved for continued processing, Bn Ops will initiate the ETP via GCRc. EEPD Policy will forward all AR MI ETPs to AR G1 with supporting documentation. Policy will notify the Bn Ops of the decision by approving or disapproving the workflow upon receipt of a decision by AR G1.

n. Bn Ops will request an ETP via GCRc to EEPD Policy to enlist the applicant outside of the 10 day window pending the AR MI exception.

o. AOC 90A is O-3 level logistics and not authorized for accessing O-1 & O-2 officers. If the position given is for 90A, OCS applicant must select from the following.

(a) 88 Transportation

(b) 91 Ordnance

(c) 92 Quartermaster

(d) All OCS applicants will be informed by the recruiter that AR incentives are offered based on the unit, the MOS/ AOC, individual qualifications, and the needs of the AR. No incentives can be guaranteed until the applicant

enlists at MEPS.

J-5. AR Prior Service Non-Duty Military Occupational Specialty Qualification (DMOSQ) Acceptance Policy

Recruiters will identify vacancies for PS in their DMOS prior to sending them to MEPS and GCs will assign PS in their DMOS whenever possible. If no DMOSQ vacancy is available the recruiter will identify will train vacancies (coded P) for which the Soldier is qualified from the G2 AR Strength Atlas found on the G2 Google+ site.

a. All will train enlistments will be for 3, 4, 5, 6, 7 or 8 years and will be served in a TPU (except as authorized in AR 140-10). The 3 year minimum enlistment allows Soldiers to become DMOSQ within 24 months as required by AR 140-10, chapter 2-6c.

(1) Enlistment will be in a TPU with an authorized unit priority code only IAW appendix J-4a.

(2) PS E-4s may enlist as will train skill level 2 as long as it is advertised for the Soldier in REQUEST.

b. If there is not a will train vacancy available a request to flip a non-will train (code N) to a will train (code P) an ETP will be sent through the chain of command to EEPD to AR G-1/G-7 approval. (See J-4b (2) (3), J- 4j and J-4j.)

(1) The LOA must state the TPU Cdr will send the PS to the appropriate AR MOS qualification training.

(2) TPU commander will specifically include any ASI or SQI for any MOS, if applicable.

(3) AR G-1/G-7 will review each request and make a determination based on MOS, TPU strength, and funding.

(4) Expected turnaround time is 3-5 working days.

c. GCs are reminded that PS will not be built in GCRC or REQUEST as Projected Specialty "J" code. PS must be built with a primary or secondary MOS only. PS will not be built as 09B if they hold an Army MOS. If the PS MOS is not available they can enlist in the will train vacancy. The only exceptions are PS Army Civilian Acquired Skills Program (ACASP) and PS from a sister Service. Will train yes vacancies are to be used for Soldiers who do not hold an Army MOS or for Soldiers who hold an MOS that is not available within the normal commuting distance of their home zip code. REQUEST will attempt to pull a vacancy for the held MOS, if that fails, REQUEST will show all available will train yes vacancies.

(1) ACASP Soldiers are authorized the Projected Specialty "J" for their projected ACASP MOS. The identified MOS will reflect the ACASP held skills.

(2) Soldiers with a specialty MOS in the 09 series are authorized to have the MOS identified as the Projected Specialty "J" code. This includes PS from a sister Service who holds an MOS that does not convert to an Army MOS. The Soldiers will be identified with MOS 09B.

d. If the vacancy type is a mobilization vacancy, coded "M" on Available Vacancy Report, and is coded will train no by AR G1/3/7, changing the will train status to yes is not authorized. No "M" vacancies will be coded as will train yes.

J-6. AR Released from Active Duty (REFRAD) for Temporary Medical Reasons

Occasionally AR Soldiers are injured or become ill while in IADT and are given a REFRAD to allow time for recovery. These Soldiers are sent home with a REFRAD memo from AR G-1.

a. Soldiers with a REFRAD will provide their recruiter with all medical documents from their physician relating to their treatment and recovery. A release from care to return to duty, with no limitations is required.

b. Recruiters will submit the documents listed below (as applicable) with a completed DD 2807-2 to the MEPS as a medical read. The DD 2807-2 must list the medical reason for the REFRAD and the read must be approved prior to projecting the Soldier for a new physical. The medical read will include:

(1) AR G-1 approved REFRAD memo with suspense date to return to training.

(2) Memo from training base explaining the REFRAD reason.

(3) DA 4856, Developmental Counseling from the training base.

(4) Line of Duty (LOD) Investigation.

(5) DA 2173, Statement of Medical Examination and Duty Status.

(6) DA 3349, Physical profile or DA 4707, Entrance Physical Standard board (EPSBD) proceedings.

(7) Medical documents pertaining to injury or illness and the release from care from the physician.

c. GCs will ensure the medical read is submitted and completed by MEPS. The GC will ensure the Soldier is cleared and that the new physical and all REFRAD related documents are uploaded in ERM. The GC will contact the ROC for assistance pulling all REFRAD REQUEST reservations and notify the Soldier, TPU, and recruiter of the new training seat reservation, and submit a Request for Orders (RFO) to MEPS as a Hometown Shipper (HTS). (See appendix P-5.)

d. MEPS medical and operations staff will:

(1) Complete the medical read and authorize a full physical examination under accession standards IAW AR

40-501, chapter 2.

- (2) Update the Soldier's record in MIRS.
- (3) Provide the GC with the new MEPS orders, travel itinerary and meal checks.
- (4) Code the Soldier in MIRS as BOMOP (No Medical Required) allowing the Soldier to ship without inspect.

J-7. REQUEST Reservations for AR AMEDD Officers

GCs may assist health care recruiters (HCRs) with processing newly commissioned AR AMEDD officers by building, confirming, and shipping REQUEST reservations. HCRs will submit hold screen and vacancy look-ups for TPU assignments after the applicant is Physical Examination Qualified (PEQ) through the respective medical Bn. Project all processing actions to take place at the MEPS through MIRS. Follow local MEPS policy for projection procedures. The newly commissioned officers will have a position on hold.

a. HCRs are required to provide a copy of the following documents to the GC:

- (1) DA 71 (Oath of Office - Military Personnel).
- (2) DD 2808.
- (3) DA 61 (Application for Appointment).

b. Reservations are the same as the enlistments, except for the following items:

- (1) Driver's license is not required.
- (2) Test scores are not required.
- (3) Category is PS.
- (4) Process as enlistment for a new accession.
- (5) Build as an officer with BCT completed (MPC Code=0).
- (6) Source of commission is normally direct.
- (7) Advanced rank reason is normally for completed necessary college requirements.
- (8) Area of concentration (AOC) must be listed along with a skill identifier (if applicable) and listed as the primary specialty.
- (9) Personnel procurement number code is 88.
- (10) Ship date will automatically default to the current date.
- (11) Enlistment date will match DA 71 date.
- (12) Provide the HCR a printed copy of the reservation to be submitted with the appointment record.

Army Reserve ROTC SMP Processing

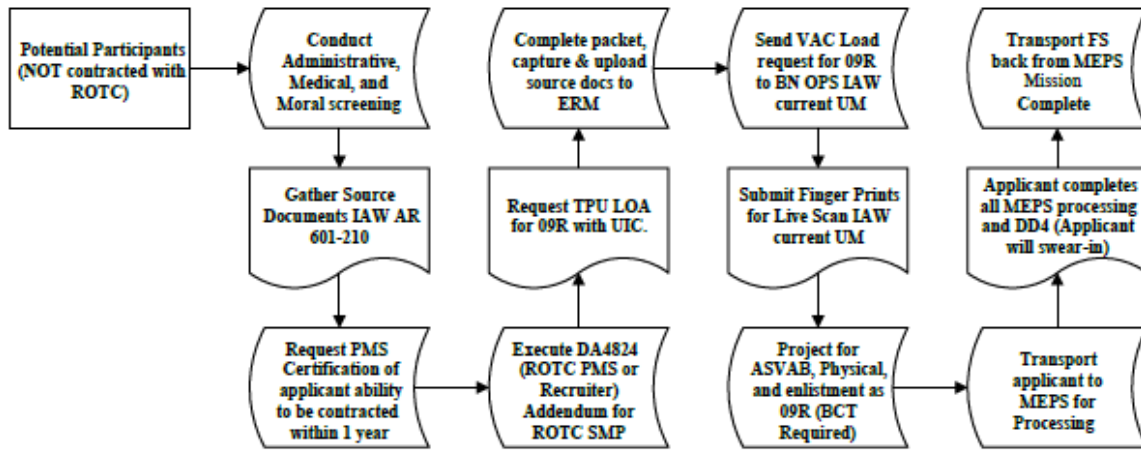

****ROTC SMP Potential Participants must take the ASVAB, a full MEPS physical and will complete all processing. This includes the DD1966, Annexes, and DD 4 and will swear-in at MEPS. These FSs must ship to BCT within 270 days of enlistment.**

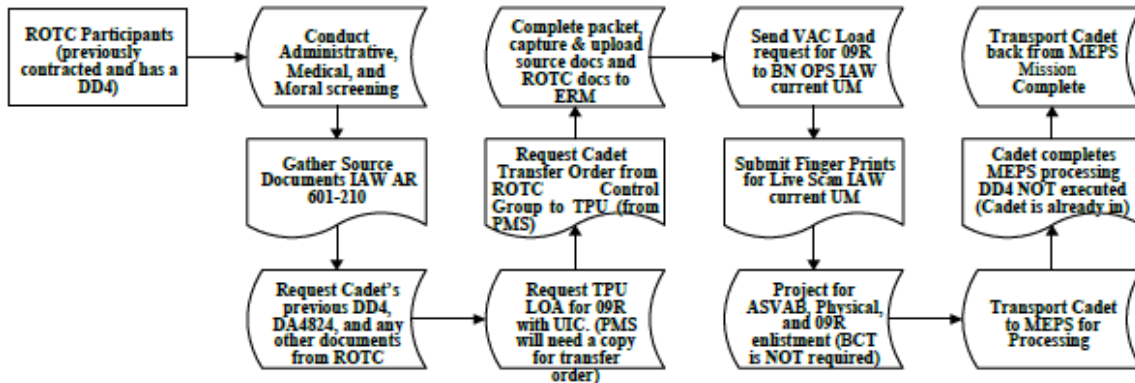

****ROTC Participants have already executed a DD4 with Cadet Command. They do NOT swear-in. These Cadets must take the ASVAB, a full MEPS physical and complete all processing. This includes the DD1966 and Annexes. BCT is not required for these Cadets. Once the Cadet has completed all processing they may leave the MEPS.**

This processing flow chart is designed to assist the recruiting force. For questions regarding Army Reserve ROTC SMP qualifications, policies, and procedures refer to AR 601-210, 9-14 and current USAREC Messages.

Figure J-1. Army Reserve ROTC SMP Processing Flowchart

Appendix K Regular Army Options and Incentives

K-1. Purpose

This appendix consolidates implementing instructions and guidance for the management of current recruiting options.

K-2. General

RA enlistment programs and options are available for qualified male and female applicants. AR 601- 210, chapter 9 lists and describes each authorized enlistment program and associated option(s).

NOTE: List all applicable statements for the applicant's enlistment in the Remarks section of DD 1966/4.

K-3. Procedures (general)

- a. The recruiter executes the selection of an option or program when pulling the REQUEST reservation for a qualified applicant.
- b. REQUEST is designed to display only those MOSs and options for which the applicant is qualified.
- c. During DEP-in the GC ensures that the applicant understands the precise nature of the option commitment and guarantee.

K-4. Procedures for Applicants Requiring ESL Training

US Army English Language Comprehension, REQUEST Option 06:

- a. This is a 4-year enlistment.
- b. Applicant must attain an AFQT score of 31 or higher on the ASVAB.
- c. ECLT/ALCPT score of 40-74.
- d. Applicant can enlist in any MOS in which they are qualified and a vacancy exists.

All NPS applicants who speak English as a second language (anyone whose records indicate he or she is not a native speaker of English and has resided in the US for less than one (1) year) or demonstrate difficulty understanding or speaking English will take the English Comprehension Language Test (ECLT) prior to recruiters making an enlistment reservation. This includes if the applicant has failed the last ECLT of record, regardless of time resided in the US.

- e. If the ECLT score is 75 or above, ESL training is not required. Applicant scoring below 75 must conduct ESL training prior to BCT IAW Table K-1. If enlisting for 09L, the ECLT score must be 80 or higher.

Table K-1
ESL calculation

ECLT	Total Weeks
40-44	25
45-49	22
50-54	20
55-59	17
60-64	16
65-69	14
70-74	13
75-79	8 * 09L Only

Table K-1. ESL calculation

- f. The GC must determine the desired training date and add the number of weeks for ESL training to the desired training date. This serves as the applicant's RECBN arrival date to secure a reservation.

- g. Applicants enlisting under this option must ship to Fort Sill, OK to in-process, prior to attending ESL training (Lackland Air Force Base, TX).

K-5. Recruiting Enlistment Programs

a. Training Enlistment Program. The Army guarantees, in writing, a specific MOS, as well as provides a guarantee to Airborne, Language, and MI MOSs and training if selected and if qualified. The guarantee is offered to qualified NPS, GNPS and PS applicants enlisting for the minimum term of enlistment authorized by REQUEST.

b. OCS and WOFT Policy:

(1) The OCS and WOFT enlistment programs are available for limited procurement of qualified male and female applicants. The number of training spaces available for these programs is based upon the needs of the Army, as determined by HRC and DA G-1.

(2) Members of the DEP or DTP may not process for OCS or WOFT.

(3) AR OCS applicants are branched IAW TPU vacancies and will acknowledge the vacancy on a DA 5586-R (Addendum to Certificate of Acknowledgment of Service Requirements in the USAR Officer Candidate School Enlistment Option).

(4) Initial MSO for all OCS and WOFT is eight (8) years with any remaining obligation to be served in the IRR;

(a) RA OCS 3 years + training and commissioned as second lieutenant after OCS graduation.

(b) AR OCS 6 years TPU and commissioned as a second lieutenant after OCS graduation.

(c) RA WOFT 6 years + training and appointed to warrant officer after WOFT graduation.

(5) An applicant may not apply for OCS for one year if they were a non-select from any Department of the Army Board. All requests to waive eligibility requirements must be submitted through HQ USAREC, ATTN: RCRO, to HQDA, Office of the Deputy Chief of Staff, G-1, ATTN: DAPE-MPO- D, Washington, DC 20310-0300.

(6) Any WOFT applicant fully qualified/not selected for two consecutive boards will be considered not select/not competitive and may not reapply for one year from the date of the DA 61, IAW DA PAM 601-6, Ch2, para 6. Applicants may request an exception to the one year wait period when more pertinent qualifications have been acquired IAW AR 135-100 para 2-5. All requests must be routed through the applicant's Company Commander. Submit all supporting documents along with HQ UF 3.4 and email request to: usarmy.knox.usarec.list.hq-g3-ocs-woft-boards@mail.mil.

c. OCS Program (Figure K-1).

(1) This section establishes procedures for administration of the OCS Program, identification of prospective OCS applicants, processing and screening procedures, and guidelines for the conduct of Bn OCS selection boards. Utilize the following processing for OCS applicants:

(2) Initial OCS screening. ASVAB and MEPS physical is completed after the applicant's initial interview to screen the applicant for OCS selection.

(3) Application packets are collated and submitted to Bn Ops for a Bn selection board.

(4) Documents needed for an application packet:

(a) Certified copy of college degree and transcripts or memorandum from the institution verifying student enrollment and status. RA and AR OCS applicants must currently be classified as a senior in their last semester of the 4-year degree producing program.

(b) DA 61 (Application for Appointment).

(c) Full-length digital photo of the applicant in color.

(d) Typed applicant essay (not to exceed one page in length) on "Why I want to be an Army Officer"

(e) Letters of recommendation (minimum of three, no more than six).

(f) Resume.

(g) DD 214, NGB 22 or other documentation needed to show PS.

(h) DA 705 (applicants must score minimum of 60 points in each event by age group).

(i) UF 601-210.10 (Security Clearance Questionnaire).

(5) Recruiting Bn selection board: Upon receipt of completed application packet(s), the designated Bn Ops Special Missions' OIC and/or NCOIC schedules an OCS selection board and QC's the packet. The board consists of three commissioned officers (O-3 and above), at least one member of the Bn OCS board must be an officer (O-4 and above) and one must be assigned to US Army Cadet Command (USACC). Bn S3s will coordinate with one of their local ROTC Professor of Military Science (PMS) to have a representative from USACC. If the USACC officer is not available to participate as a panel member of the board an ETP may be requested via a memo from the Bn S3 to G3, Special Programs and Boards prior to the board date. The memo must address the reason why the USACC officer is unavailable. The objective of the board is to identify the degree to which the applicant has developed attributes that show potential for a successful career as a professional Army commissioned officer. The applicant's past behavior in a variety of situations is evaluated to predict future performance. Applicant should demonstrate character, competence and commitment. After the board adjourns, the Special Missions OIC/NCOIC completes the following for inclusion in the applicant's ERM:

(a) UF 601-210.11 (Board Evaluation Sheet) (signed by recommendation board members).

(b) UF 601-210.12 (signed by the Bn Cdr).

(6) Applicants selected by a USAREC Bn board have ten (10) working days after board result release to enlist into the RA or the AR. Bn OPs notifies G-3, Special Programs and Boards immediately if any selected applicant declines to enter the FSTP or RA DS. GCs will call the ROC to procure a training seat. AR OCS must be in the DTP for a minimum of 90 days, the ROC will schedule a training seat 90 days from the date of accession.

(7) The Bn Ops Special Missions must publish a board results memorandum and forward a copy to USAREC G3, Special Programs and Board (usarmy.knox.usarec.list-hq-g3-ocs-woft-boards@mail.mil) NLT the published date with the following information:

(a) RSID.

(b) Name of applicant.

(c) PRID.

(d) AR or RA.

d. WOFT Program (Figure K-1).

This section establishes procedures for the administration of the WOFT (RA) Program to include screening, processing and guidelines for the conduct of all Bn WOFT (RA) recommendation boards.

(1) Initial WOFT screening. Utilize the ASVAB, Selection Instrument for Flight Training Test (SIFT), and completed MEPS physical after the applicant's initial interview to screen for eligibility.

(2) The unit schedules the applicant for the Class I Flight Physical through the nearest Military Treatment Facility (MTF) with Flight Surgeon on staff. The MTF forwards the flight physical (DD 2808, DD 2807-1, DD 2807-2, and all test results) to Aeromedical Center, Fort Rucker, AL via AERO medical data system for review and final disposition.

(3) The flight physical is returned to the MTF once the final disposition is given. The recruiter/Bn Ops will request a copy of the approved flight physical from the medical facility upon release of the examination. The Bn Ops uploads the completed application with supporting documents in the applicant's ERM

(4) The Aeromedical Center, Fort Rucker reviews the Class 1 Flight Physical to determine the applicant's medical qualification for WOFT. Upon receipt of approval of the physical from Fort Rucker, the applicant is scheduled for the next USAREC level WOFT board.

(5) Application packets for each applicant are collated and submitted to USAREC G3, Special Programs and Boards (usarmy.knox.usarec.list-hq-g3-ocs-woft-boards@mail.mil). The following documents are needed for an application packet:

(a) Certified copy of HS diploma and/or transcripts, and college degree and/or transcripts. If the applicant is a GED holder he/she must have the required college credit hours to be eligible to enlist with Education Code "128", per AR 601-210, chapter 2-7c (7). Tier 2 are not authorized.

(b) DA 61

(c) Full-length digital photo in color

(d) Typed applicant essay (not to exceed one page in length) on "Why I want to be an Army Aviator".

(e) Letters of recommendation (minimum of three, no more than six).

(f) Resume.

(g) DD 214, DD 215 or NGB 22 to show PS.

(h) UF 601-210.12 (signed by the Bn Cdr).

(i) DA Form 705 (applicants must score minimum of 60 points in each event by age group).

(j) UF 601-210.10.

(k) Class I Flight Physical completed (DD 2808 with qualified physical stamp).

(l) USMEPCOM 680-3ADP showing test scores and DAT results.

(m) UF 601-210.08, if applicable.

(6) Bn Ops: Upon receipt of completed application packet(s), the designated Bn Ops Special Missions' OIC/NCOIC completes the following for inclusion in the applicant ERM and forwards, NLT published date, to G-3, Special Programs and Boards (usarmy.knox.usarec.list.hq-g3-ocs-woftboards@mailmil) for the USAREC WOFT selection board:

(7) Upon receipt at G3, Special Programs and Boards, the application is screened to ensure all documents are accurate and in ERM.

(8) Selected applicants have 10 working days after selection result release to enlist. Bn Ops notifies USAREC G3, Special Programs and Boards immediately if any selected applicant declines to enlist.

e. Army Music.

(1) Applicants for the Army Music Program access under MOS 42R with an ASI, 9B through 9X, identifying the instrument played. Special Bands individuals selected by DA process as MOS 42S with no ASI.

(2) Applicants applying for MOS 42R will first be prescreened by respective Bde Band Liaisons. Once the

liaison determines the applicant's musical potential to enlist in the Army Music Program, the recruiter will ensure the applicant meets all basic eligibility requirements.

(3) Following eligibility screening, the Bde Band Liaison will coordinate for a live assessment with the applicant. Due to the complexity of the ASI 9X, the applicant must travel to the Army School of Music in Virginia Beach, Virginia for a live assessment.

(4) The applicant is placed on an order of merit list (OML) based on their audition score, and a board is held monthly at HQ USAREC, Special Programs and Boards to select the most qualified applicants for training seats.

(5) The Army Musician Proficiency Assessment (AMPA) form is required for the enlistment record.

(6) Direct any issues or questions on the Army Music Program to respective Bde Band Liaisons or G3 Special Programs and Boards at (502) 626-0456 or email usarmy.knox.usarec.mbx.hq-g3-band@mail.mil.

f. Airborne Training Option.

(1) This option guarantees training in the basic airborne qualification course and a possible assignment to a unit listed in REQUEST, if airborne qualifications are maintained. (Unassigned airborne reservations do not guarantee an assignment to an airborne unit. Temporary reservations can be made prior to an airborne screening/ inspection.)

(2) GCs will ensure all applicants enlisting for the airborne option have passed the airborne screening/ inspection by the CMO prior to DEP/DTP-in.

NOTE: Applicants with an approved USAREC medical waiver and are airborne qualified by the CMO are qualified for the airborne option.

K-6. Foreign Language Recruiting Initiative (FLRI) (RA and AR)

Program 9A, US Army Training Enlistment Program REQUEST Option 10, US Army Trainee English Second Language (ESL).

a. FLRI is for applicants whose primary language is other than English (English is their second language). It is not for applicants seeking to learn a new language.

b. Applicants are not eligible if:

(1) They have attended US schools nonstop from age 10 thru high school graduation.

(2) They have 2 or more years of post-secondary education in the U.S.

c. Applicants are eligible if:

(1) They are non US born (excluding Puerto Rico) with a mix of foreign and US education from age 10; having a mix of foreign and US education from age 10 thru high school graduation.

(2) They are US citizens and moved from the US to another country at any age prior to 10, having a mix of foreign and US education from age 10 thru high school graduation.

Example: applicant was born in the US; moved to Mexico at age 7; attended school in Mexico. Then moved and attended school in the US at age 15 and graduated from US school. This applicant is eligible for FLRI.

d. Individuals must meet the following additional criteria prior to enlistment:

(1) NPS only.

(2) Be a Tier 1 grad or senior.

(3) Attain an AFQT score of 21-30 on the ASVAB with a qualifying score of 54 in assembling Objects (AO). Applicants who took the ASVAB in HS as part of the Career Exploration Program (CEP) must retest at MEPS due to the AO subset not being included in the CEP.

(4) Attain an ECLT or American Language Course Placement Test (ALCPT) score between 40 and 74. ECLT retesting to obtain a lower score is not authorized to qualify applicants that have already passed the ECLT and do not meet ASVAB requirements.

NOTE: ETPs for ECLT scores of 35-39 may be considered on a case by case basis. AO score cannot be waived.

e. GC informs FLRI applicants of the following pertinent information.

(1) The guarantee of training in a specific MOS/CMF, specific assignment to a specific station, and unit or command area for RA applicants is not granted until successful completion of training.

(2) AR applicants are initially assigned to the locat TPU with a valid 09C vacancy.

(3) Ship all FLRI to Fort Sill, OK for in-processing prior to ESL at Lackland AFB, TX.

(4) Based on the Solders current ECLT score, Soldiers may attend ESL for up to 30 weeks.

f. FLRI is not available as a temporary reservation.

g. The ROC executes all FLRI reservations.

h. AR applicants require a vacancy load for 09C. Send the vacancy load request to EEPD, AR Senior ROC NCO and USAREC AR liaison prior to enlistment date. AR FLRI Soldiers who successfully complete ESL and pass the ECLT with a 75 or higher will take the AFCT. The 09C reservation will be reno'd to a valid cacancy with the TPU of assignment. MOS selection will be dependent upon the Soldier's qualifications and training seat

availability.

K-7. Partnership for Youth Success (PaYS) (RA and AR)

This program provides Soldiers an opportunity to interview with an employer selected during their enlistment process. Soldiers must successfully complete their initial tour (RA) or IADT (AR) to qualify for the interview. Recruiters and GCs have the ability to select two PaYS jobs.

a. PaYS is available for RA/AR NPS/GNPS/PS. PaYS is also available to ROTC cadets.

(1) NPS applicants must be a HSSR or a HSDG with an AFQT of 31 or higher.

(2) PS/GNPS processing for either RA or AR qualify for PaYS, no IRR to TPU transfers. There is no AFQT education requirements beyond normal enlistment qualifications.

(3) When the GC pulls or converts a reservation with PaYS option, the PaYS Statement of Understanding (SOU) - Partnership for Youth Success (PaYS) has been incorporated in the annexes for acknowledgment and signature of both the applicant and GC.

b. Recruiters will:

(1) Discuss PaYS with applicants, their influencers, educators and local business owners.

(2) Review the PaYS program with the FS during the FS orientation and will ensure the FS has a copy of:

(a) The SOU.

(b) RPI 274.

(c) RPI 275 (PaYS Pocket card).

(d) PaYS website address: www.armypays.com. Additional links:

<http://IKROme.usaac.army.mil/web/pays/home1PaYS> Pamphlet: http://span.usarec.army.mil/sites/HQ/G7-G9/PaYS%20Documents/USAAC_Pam_601-1.pdf Advanced User Guide:

<http://span.usarec.army.mil/sites/HQ/G3/Training/TSP/Documents/RZ%20GRCc%20Advanced%20User%20Guide.docx>

Figure K-1. OCS & WOFT Selection Process

OCS & WOFT Selection Process

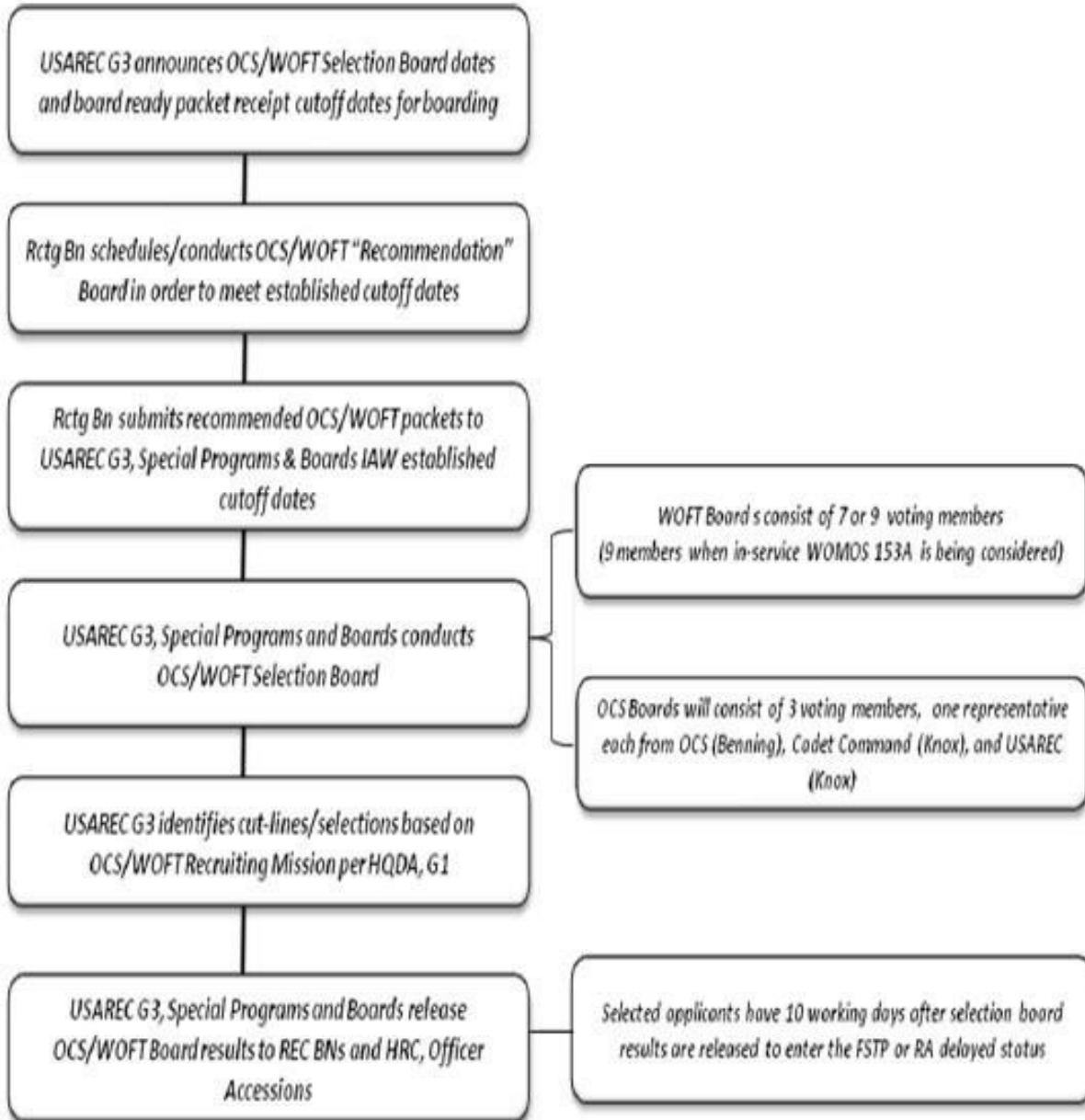

Figure K-1. OCS & WOFT Selection Process

Appendix L Overseas Processing Procedures

L-1. Purpose

This appendix establishes standardized guidelines for processing overseas enlistments and provides the procedures required to process these applicants.

L-2. General

Overseas applicant processing is critical to USAREC's mission.

- a. Overseas processing will be accomplished by GCs assigned overseas who have been awarded the ASI-V7.
- b. ISGs who are ASI-V7 qualified can be granted the authority to complete applicant processing in the absence of the assigned ASI-V7.
- c. Recruiting personnel performing duties in the absence of the assigned ASI- V7 will adhere to all policies and regulations.

L-3. Policy and Procedures for Securing a Social Security Number (SSN) for Future Soldiers Who Enlist with a Temporary Identification Number (TIN).

- a. The Social Security Administration Offices (SSA) in Guam and Honolulu will process FSs for a SSN.
- b. 6thBde/Portland Bn will:
 - (1) Ensure that ship dates for FSs are at least 60 days from reservation to allow for SSN processing. Arrive FSs to Guam/ Honolulu at the earliest possible date after entering the DEP/DTP in order to process for SSN.
 - (2) Recruiters will contact SSA to schedule processing appointments for groups of applicants greater than 8.
 - (3) Recruiters will notify the appropriate SSA office NLT of 72 hours in advance of arrival. When escorting the FS to the SSA office, recruiters must wear a uniform and present their Military Identification Card (CAC) to the SSA office official.
 - (a) Guam office (671) 635-4212
 - (b) Honolulu office (855) 572-4879
 - (4) Recruiters will ensure that FS hand carry the following documentation with them when applying for a SSN.
 - (a) US Passport
 - (b) INS I-94 and associated paperwork
 - (c) DD 4 from the DEP/DTP enlistment
- c. After applying for SSN, FSs return to their home of record. The SSA will mail the hard copy SSN card to the recruiting station, 14-21 days after application submission.
- d. Recruiters will email Honolulu MEPS Army GC office with the new SSN so that it can be updated in MIRS. After MEPS updates the SSN in MIRS they will generate 680ADPs which will be scanned into the FS record by the Honolulu GCs.
- e. Station Commander will email the ROC a list of TINs that need to be updated in REQUEST and the ROC will reply with a confirmation email. After receiving confirmation from the ROC that the records have been updated, the recruiting station will update all TINs to SSN in GCRc.

L-4. Guidelines

- a. Europe:
 - (1) Projecting; Project all applicants to Europe MEPS (code A07) for the correct date of each phase of processing (test, physical, DEP-in) except for shipping which is automatically projected by GCRc.
 - (2) Testing: All tests are given at the education centers and the results are electronically transmitted to Albany MEPS. MIRS automatically updates GCRc when the test is graded. Build and pull an applicant reservation if there is undue processing time from test to receipt of test scores. The recruiter can input the AFQT and line scores that are provided on a print out by the Test Site Coordinator at the education center. A temporary reservation can be converted to a permanent reservation with the print out results. However, a FS cannot ship without the actual scores built in the record.

NOTE: Estimated line scores populate when the AFQT is added.

(3) Medical; Physicals are conducted at Military Treatment Facilities (MTFs) and once completed; the recruiter will upload the DD 2807-1 and DD 2808 in ERM. This process occurs whether the applicant passes the physical or not. The Bn Ops is responsible for ensuring compliance by validating the applicant's record.

(4) NOTE: The MTFs establishes the PULHES and reservations are pulled based on those PULHES. HIV and DAT testing occurs at the RECBN. Shipping; Soldiers shipping from Europe are not required to process through MEPS. The recruiter ensures that the electronic copy of the DD 1966 series is in ERM. Albany GC shop prints a

completed DD 1966/1 on the Soldier's ship day and supplies it to MEPS for submission to MIRS. MEPS inputs the data within one (1) business day. This process is imperative as the RECBN does not accept individuals that do not have accession data input in MIRS. The recruiter will ensure that all required documents per this regulation and the GCRc User Manual are uploaded in the record prior to the Soldier shipping. All European FSs will ship on Tuesdays and Wednesdays only.

(a) If ship date is far enough out the packet is Fed Ex to Albany MEPS. The record is updated and filed.

(b) If ship date is soon, the SGC talks directly to the MTF to get records and will confirm no inspect.

(5) European Overseas Courtesy Shipping; Medical inspects for shipping (RA and AR) from Europe that normally do not ship from a MEPS location is not required, unless changes to the FS's medical eligibility is noted. Follow this process:

(a) Station commander of the shipping station will:

1. Complete a UF 601-210.20 (FS Hometown Shipping Checklist) three (3) working days prior to scheduled ship date to determine if there have been any changes to the FS's medical eligibility or if there were previously undisclosed medical issues.

2. Upload the completed UF 601-210.20 in the FS's ERM.

(b) If there are no changes to the FS's medical condition, no inspect is required (to include height and weight). The FS can ship as scheduled after processing through the ship counselor. The GC will confirm the UF 601-210.20 is completed and uploaded in ERM.

(c) Follow all other courtesy shipper procedures listed in appendix P-4 of this regulation.

b. Japan and Korea:

(1) Projecting; Project all applicants to the Tokyo, Japan MEPS (code C86) or Seoul, Korea MEPS (code C87) for the date of each phase of processing (test, physical, DEP-in) except ship, which is automatically projected by GCRc.

(2) Testing; All tests are given at the education centers, and the results sent to Honolulu MEPS. See L-4a (2).

(3) Medical; See L-4a (3). HIV and DAT testing occurs at the RECBN.

(4) Shipping; Soldiers shipping from Japan and Korea are not required to process through MEPS. The recruiter must save an electronic copy of the DD 1966 series. Email the copies (encrypted) to Honolulu MEPS GC shop (all personnel). The SGC prints a completed DD 1966/1 on the Soldier's ship day and supplies it to MEPS for submission to MIRS. MEPS must input the data within one (1) business day. The recruiter will ensure that all required documents per this regulation and the GCRc User Manual are uploaded in the record prior to the Soldier shipping. All FSs will ship on Monday and Tuesday only.

c. Pacific Rim:

(1) Shippers (RA and AR) from Pacific Rim locations that normally do not ship from a MEPS location.

(2) Recruiter or station commander will:

(a) Complete a UF 601-210.20 three (3) working days prior to scheduled ship date to determine if there have been any changes to the FS's medical eligibility or if there were previously undisclosed medical issues.

(b) Upload the completed UF 601-210.20 in the FS's ERM.

(3) If there are no changes to the FS's medical condition no inspect is required. The FS can ship as scheduled after processing through the ship counselor. The GC will confirm the UF 601-210.20 is completed and uploaded in ERM.

d. Guam/Saipan:

(1) Projecting; All applicants will be projected to the Agana, Guam/Saipan MEPS (code C85) for the correct date of each phase of processing (test, physical, DEP-in) with the exception of shipping, which is automatically projected by GCRc. Exception to this policy are those applicants who do not have a SSN and are issued a TIN by MEPCOM. The TIN applicants must be projected for every phase after receiving their TIN. MEPCOM will issue TINs as directed by DOD. All enlistees must have a valid SSN and their GCRc record updated with the new number prior to shipping.

(2) Testing; The Honolulu MEPS has an OPM tester in Guam/Saipan for testing purposes. The test scores are sent to Honolulu MEPS for grading and input in MIRS.

(3) Medical; See L-4a. HIV and DAT testing occurs at the RECBN

(4) Shipping; Soldiers shipping from Guam/Saipan are not required to process through MEPS. The recruiter must save an electronic copy of the DD 1966 series. The copies will be emailed (encrypted) to Honolulu MEPS GC shop (all). All FSs will ship on Tuesdays and Wednesdays only. See L-4a(4)

e. American Samoa Federated States of Micronesia, Republic of Palau, and the Republic of the Marshall Islands:

(1) Projecting; Project all applicants to the Honolulu. MEPS (C73). A projection window will be created for the first Saturday of the DEP Trip.

(2) Testing; Testing is accomplished by MEPS personnel from the Honolulu MEPS during schedule testing trips. American Samoa also has weekly enlistment testing. All tests are mailed to the Honolulu MEPS for grading and input to MIRS

(3) Medical: The physical is administered by MEPS personnel during the DEP trip. HIV and DAT testing occurs at RECBN.

(4) Shipping:

(a) American Samoa- Future Soldiers who enlisted from American Samoa will ship through the assigned V7 at the Samoa Recruiting Station. Ship projections are made through the Honolulu MEPS. Honolulu MEPS will provide orders, flight itinerary and meal vouchers for all Samoa shippers.

(b) RMI, ROP, FSM- Future soldiers who enlisted during DEP Trips on the compact agreement islands will be projected to ship through the Agana MEPS (C85). The SGC at the Agana MEPS is responsible for orders, flight itineraries and meal vouchers.

(c) If there are no changes to the FS's medical condition, no inspect is required. The FS can ship as scheduled after processing through the ship counselor. The GC will confirm the UF 601-210.20 is completed and uploaded in ERM.

(d) The GC must save an electronic copy of the DD 1966 series. The copies will be emailed (encrypted) to Honolulu MEPS GC office (all).

NOTE: Applicants enlisting from Republic of Marshall Island, Republic of Palau and the Federated States of Micronesia typically do not have social security number. They will issued a TIN number from Honolulu MEPS testing section after testing. This number will be used as there SSN for enlistment purposes. See L-4 for TIN guidance after enlistment

(5) Use LS results for both DEP-in and DEP-out. USMEPCOM at this time does not have the means to capture FPs for overseas applicants. Recruiting personnel are responsible for the successful submission and posting of FP results and the required investigation submission and acceptance. Guidance counselor at ship out is responsible for ensuring the ETNAC memo has been uploaded in ERM. Live scan and DD form 369(s) are not required for enlistment purposes for applicants enlisting on a TIN number.

f. Remote areas of Alaska: There are several remote areas in Alaska that warrant remote packet completion.

(1) Projecting/packet completion; Project applicants for the Anchorage MEPS. There are certain remote locations in Alaska that require the recruiter to complete the enlistment record via Army Career Explorer (ACE), email or fax without the benefit of face to face verification. Document verification occurs with the assistance of local school officials, police personnel or ARNG NCOs. Hand carry originals to the MEPS for verification by the assigned GCs.

(2) Testing (or utilize school ASVAB), medical and shipping is accomplished at the Anchorage MEPS.

(3) LS results are not required for applicants processing from remote locations in Alaska.

Appendix M Waiver Procedures

M-1. General

This appendix contains procedures for waiver processing. These procedures supplement AR 601-210, chapters 2, 3, 4 and 5.

M-2. Policy

a. Waivers that were granted by other Services or components of the US Armed Forces may not be used for RA or AR enlistment. This policy pertains to pre-accession waivers that were approved but either the applicant did not enlist, or was discharged from their DEP. For applicants that received a waiver of any type from the ARNG and are still serving, submit a suitability ETP to EEPD Waivers via workflow.

b. Applicants may not enlist the same day that a conduct or administrative waiver has been approved without an ETP from the Bde Cdr.

c. If an applicant has an approved conduct waiver and commits or is convicted of a new offense, the applicant must submit a new conduct waiver to the approval authority. The applicant record is updated as follows:

(1) The recruiter runs a new police record check(s) (DD 369) and court check(s) (UF 601-210.02) (see AR 601-210, chapter 2-11) and adds any new information to the applicant's security clearance application.

(2) Initiate new waiver through a workflow. Update and upload all required documents and memos. Completely QC the waiver packet and forward the waiver workflow to the Bn Cdr for approval or recommendation to the approval authority in GCRc remarks section.

d. Physical requirements. The Bn Cdr may approve a waiver prior to the applicant taking the physical where

he/she is the approval authority. A completed physical is not required to submit administrative waivers requiring USAREC level approval, except in cases where an applicant must take an APFT or demonstrate some physical ability. A complete physical is required for all other USAREC waivers.

e. Administrative and conduct waivers are valid for six (6) months from the date of approval. Medical waivers are valid until the physical expires.

f. In the event of the applicant requiring multiple waivers (conduct and medical), the Bn Cdr must approve the conduct waiver before submission of the medical waiver.

g. Documents (such as police checks, waivers, references, etc.) obtained by recruiters of other services or components are not accepted for RA or AR waiver processing.

M-3. Conduct Waiver Procedures

a. The Company and Bn Cdr, or interim Cdr, (on assumption of command orders) interviews all applicants requiring a conduct waiver. Annotate results of the interview in the waiver workflow (GCRc remarks section) or in a MFR uploaded in ERM. The interview will reflect the details of the conversation, as well as a description of the disqualification and why it no longer exists.

b. An AR Soldier who unintentionally fails to reveal conduct requiring a waiver, that occurred prior to accessing, cannot ship to IADT without a retention letter from their unit IAW AR 135-178, chapter 7-4 and an approved waiver. Submit a conduct waiver for the charge or offense to the appropriate waiver approval authority provided the first O-6 or higher commander in the AR Soldier's chain-of-command approves the Soldier for retention and training. All additional information is added to the Soldier's security clearance application, DD 1966, and the Cdr's disposition noted in the Remarks section of DD 1966. Upload all applicable pages of the security clearance application, DD 1966, and copy(s) of written unit notification and decision in the Soldier's ERM.

c. Submit a detailed and chronological description of all offenses (to include traffic violations) from the applicant. Upload the applicant statement as part of the documentation for the waiver packet.

M-4. Administrative Waiver Procedures

The majority of administrative waivers are dependency and re-enlistment eligibility (RE) code waivers.

a. Dependency

(1) The Company and Bn Cdr, or interim Cdr (on assumption of command orders), reviews the DA 3072-2 (Applicant's Monthly Financial Statement) to validate the applicant's ability to support his/her family.

(2) Applicants requiring a dependency, parenthood, hardship, pregnancy, or a dual military member waiver will complete DA 3072-2 (Applicants Monthly Financial Statement). The applicant fills out the form using his or her monthly income and liabilities against civilian and military pay. Instructions for preparing the form are:

(a) Blocks 1 and 2: Self-explanatory

(b) Block 3: Enter current income or if currently unemployed, enter monthly salary and termination date of the last period of employment. Other income includes spouse's income, money from odd jobs, and child support. The applicant must state clearly the source of the income. Other income if enlisted should cover any anticipated income while serving in the military from sources other than military.

(c) Block 4a: Liabilities against current income include all expenses paid out by the applicant and spouse (such as credit cards, loans, utilities (to include cell phones) and child support). Explain and detail what payments of other indebtedness or financial obligations in block 6.

(d) Block 4b: Liabilities against military income include most of the liabilities listed in block 4a unless that particular debt is paid prior to enlisting. In this case, explain it in the remarks section. Complete this block regardless of whether processing for RA or AR. When completing this block, do not assume housing is provided.

(e) Block 5: Include all assets owned (for example boats, RVs, mutual funds, and certificates of deposit).

(f) Block 6: Use this block to clarify anything on the form where a question might arise. This block includes any pertinent information regarding current and future financial stability.

(g) The applicant and a witness sign the form.

(3) Review the statement from the person responsible for the care of dependent(s), ensuring they are functionally able to care for the dependent(s) with whom they are entrusted. In cases of a hardship waiver, ensure the statement supports the claim that the hardship no longer exists.

(4) Include the Company and Bn Cdr applicant interview in the waiver packet prior to the electronic submission of the waiver to EEPD via workflow.

NOTE: Applicants found to be in arrears for child support may only continue to process if there is no pending criminal action to secure payment. This is determined through LS, DD 369/court checks as appropriate. Applicant may continue to process once arrears are paid to the court's satisfaction (when applicable).

b. Admin RE Code requirements

(1) The complete discharge/separation packet uploaded in ERM.

(2) The DD 214, NGB 22 and any applicable discharge/separation orders. If AR discharge, obtain PERNET or similar printout that shows a narrative reason for separation and "Current Organization" affiliation (should be CUR ORG Y).

NOTE: Pre-Accession RC separations that result in an "Uncharacterized" characterization of Service must have an exception to process without a hardcopy RE code waiver prior to processing. Include an explanation from the applicant why they could not ship and why the condition no longer exists, and any other supporting documentation. For AR losses, provide the PERNET N10 screenshot.

(3) Applicant statement outlining any factors in the separation.

(4) Company and Bn Cdr Interviews.

(5) To allow a comprehensive whole-person review of the applicant's waiver, include a description of any applicant law violations for all waivers (except medical).

NOTE: Exceptions to process the waiver without the discharge packet will be considered on a case-by-case basis provided all means to obtain the documents have failed. Provide the FL142 results, a description of the efforts taken to retrieve the documents, and any supporting via "Missing Documents" ETP via workflow to Policy attention "EPPD- Waivers Branch.

M-5. Medical Waiver and Prescreen Procedures

All medical supporting documentation submitted for a Med Read will be uploaded into ERM prior to submission of documents to MEPS Chief Medical Officer (CMO). Refer to USMEPCOM Medical Prescreen SOP, dated 01 June. 2018.

a. Processing a medical waiver:

(1) Required documentation for all medical waivers:

(2) DD 2807-2 completed by the CMO.

(3) DD 2807-1

(4) DD 2808

(5) 680-ADP

(6) Any applicable medical records related to the disqualifying condition that have been reviewed and annotated by the CMO (first and last page stamped and initialed, pages numbered IAW USMEPCOM regulation 601-23). If uploading a large number of documents, upload in black and white, 300 or less DPI. For additional assistance, contact the HRC Help Desk at (502) 613-7777, Option 2 then Option 1.

b. Consults, civilian medical records, and any document used as supporting medical evidence will have the CMO initials and stamp. Once obtained, the documents will be uploaded to the applicant's ERM tree using appropriate medical folders. All information used to support a medical waiver will be uploaded to the medical folder. Additional folders have been added to ERM to support this requirement. It is critical for the individual uploading medical records to have them arranged in a chronological order. Use the comments box of the workflow to point out specific information that could easily be overlooked.

c. All medical records and supporting documents used for prescreen and medical waiver processing must be routed through the CMO prior to electronic submission of a medical waiver workflow. This includes requests to physical.

d. Although the Command Surgeon team is the disposition authority for medical disqualifications, the CMO must concur with the final accession PULHES assigned to the applicant. This is the primary reason they must be aware of any and all medical documentation. Waiver requests that are missing information or CMO initials/stamps will be returned without action.

e. Routing to the CMO prior to waiver submission includes prescreens, resubmission to a request that was returned without action (includes consults), and any additional supplemental information.

f. As a reminder, all medical actions require an up-to-date USMEPCOM 680ADP.

g. Initiate a medical waiver workflow upon GC notification of applicant disqualification.

(1) PS and GNPS applicants discharged from any Service or component of the Armed Forces for medical reason requires a medical waiver regardless of MEPS physical result. The approval authority is USAREC Command Surgeon. Additional documentation for specific discharge/separation:

(a) Failure to meet medical procurement standards. Submit DA 4707 (Entrance Physical Standards Board (EPSBD) Proceedings).

(b) Personality Disorder and Physical Condition Not a Disability. Submit DA 3822 (Report of Mental Status Evaluation or admin or medical documents with psych diagnosis).

(c) Disability Severance or similar. Submit DA 3947 (Medical Evaluation Board Proceedings), DA 199 (Physical Evaluation Board Proceedings), MEB Narrative Summary.

(2) The Command Surgeon has the authority under the provisions of AR 40-501, chapter 7-8e, to revise the physical profiles for approved medical waivers. Any change made by the Command Surgeon to the physical profile is valid for enlistment. Approved waiver does not guarantee qualifications, exceptions from the proponent may be required.

(3) Stamp all changes made to an applicant's physical profile by the Command Surgeon indicating the new physical profile on the workflow.

(4) Recruiting personnel will not request the applicant to perform any exercise or obtain civilian medical tests related to the applicant's condition or a physical fitness test unless directed/requested by the USAREC Command Surgeon via workflow.

M-6. Counseling of Applicants

a. Take care in counseling applicants and/or influencers on waivers to prevent frustration and confusion on the part of both the recruiter and the applicant.

b. Advising applicants of denial of waivers. Recruiters inform applicants that the application for waiver of disqualification was not favorably considered. Under no circumstances will recruiting personnel disclose the name, organization, or contact information of the final disposition authority. When processing PS waivers, the individual is advised that the denial of the waiver was based upon a thorough evaluation of their PS records in conjunction with their current waiver request. Only provide the applicant their personal medical records or documentation. Do not provide the applicant any USAREC or MEPS generated documents, to include waiver workflows received via email or GCRC.

M-7. Supporting Documents

a. Use DD 370 for required references. (The individual providing a character reference for an applicant may compose his or her own original letter rather than using the DD 370. Ensure that applicant identification data is included in the letter or statement.)

b. Recruiters will obtain the court documents and police incident report for the charge(s) requiring a waiver (DD 369s are also required IAW AR 601-210, chapter 4). Claim any fees charged by the court for copies of court documents as reimbursable expenses for documents in the same manner as fees for copies of birth certificates or other official documents. Reimbursement is not authorized if the charge for the court document is for a purpose other than a copying expense. Recruiters will check the online Police Agency List (PAL) via "My Launcher" on IKROME.

c. The UF 601-210.14 (formerly FL 146) is valid for five (5) years. If the date or modified date on the PAL is outside of five (5) years of UF 601-210.14 is no longer valid.

(1) UF 601-210.14 will be used to solicit clarification on the release of arrest and/or arrest conviction information from all state and local law enforcement agencies. The UF 601-210.14 will be prepared by BDE and/or BN OPS and signed by the respective BDE and/or BN Cdr or XO. UF 601-210.14 may be electronically generated. The generated form must contain all data elements and follow the exact same format of the existing printed form. BN OPS will maintain their respective Bns PAL (police agency listing) for all agencies located within their BN OPS environment. SCs will identify police agencies within their areas that require updated policy agency listing(s). RSs will update the PAL as necessary by sending a new UF 601-210.14 to applicable police agencies. All police agency listings that are expired will require a new UF 601-210.14 verified through the respective police agency and updated by BN OPS to the PAL within IKROME. BN OPS will ensure all listings remain updated and unexpired

(2) PAL search (es) will be uploaded to the appropriate folder in ERM. It is no longer required to upload a DD 369 when a PAL search is uploaded for an agency that does not release.

(3) BN OPS will generate a monthly report of their PALs and submit the status of their assigned agencies to their BDE. BDE units will ensure their BNs remain compliant and update or complete all required PAL updates.

(4) When recruiting personnel outside of a BN footprint identify an expired PAL they may inform USAREC HQ by emailing the police agency information to usarmy.knox.usarec.mbx.hq-g3-rcro-eeepd@mail.mil with the subject "EXPIRED PAL". EEPD Policy personnel will provide oversight ensuring listings are updated.

d. The UF 601-210.02 is valid for six (6) months. Use the UF 601-210.02 to obtain court information when the court will not furnish a copy of court documents or charges a fee other than copying expense, but will provide information about the applicant's court history. Recruiters will ensure all information required and available is recorded on the form. If the court will not complete the form nor furnish court documents, but will allow the recruiter to review court records, the recruiter will record the court history on UF 601-210.02 and sign the form indicating that they extracted the information from official court records. Telephonic court checks can be used by following the same procedures as telephonic police checks IAW AR 601-210. This does not apply to the requirement of obtaining a police incident report.

e. DD 369 used as part of the waiver request are valid for six (6) months. If new charges arise after police

checks have been complete, obtain new checks.

f. Utilize the UF 601-210.04 to obtain a report from a correctional facility for all applicants who have been detained, committed, or confined in a law enforcement facility. Confinement and detainment are applicable only when the applicant is restrained from leaving the law enforcement facility, by whatever means, for a period in excess of 24 hours. Obtain the UF 601-210.04 for applicants who were under house arrest from the person having responsibility for monitoring the program. The UF 601-210.04 is valid for six (6) months.

g. UF 601-210.08 (Waiver Worksheet) is required for all waivers except medical waivers. Only page 1 of the UF 601-210.08, is required to be uploaded in ERM for all conduct and administrative waivers, as well as USAREC level suitability reviews. The workflow generated and processed in ERM/GCRc serves as page 2 of the UF 601-210.08 (Recommendation for Approval/Disapproval). The UF 601-210.08 will include all offenses with complete dispositions in chronological order

M-8. Personal Conduct

a. Conduct standards deal with acceptability of persons with police records. They are designed to screen persons likely to become serious disciplinary problems and impact the performance of military missions.

b. Apply the whole person concept in determining the applicant's conduct qualification for enlistment. Areas of consideration under this concept include number of offenses, severity of the charges, the actual sentence, and applicant's age at time of the violation. Other considerations are physical qualification for enlistment, employment history of applicant, educational achievements of the applicant, and favorable comments from probation and parole officers, employers, and school officials.

NOTE 1: AR 601-210, chapter 4-2 outlines what requires a suitability. This is "at a minimum", meaning a commander may conduct a suitability on any charge(s) deemed questionable. This includes excess traffic tickets.

NOTE 2: Any offenses that would have required a waiver if guilty/OAD requires a suitability review.

Exceptionally meritorious cases are granted conduct waivers. These cases must present clear evidence of rehabilitation and assurance that the individual will not become a disciplinary problem. The commander will closely adhere to the above criteria for conduct waiver processing.

M-9. OCS Waivers

a. Age exceptions. Applicants requesting an exception for age to the OCS enlistment option will have a complete packet with a request for an exception submitted to EEPD Policy. For all OCS waivers (RA and AR):

(1) RA and AR NPS and PS applicants entering into OCS must enter AD or ship to training by their 33rd birthday and must graduate and accept commission prior to age 34.

(2) PS personnel entering OCS must not have more than nine (9) years of Active Federal Service upon arrival at OCS.

(3) Age ETPs for applicants who are 33 years old or older are considered for meritorious cases.

b. Medical waivers. Medical waivers for the OCS enlistment option are the same as for any applicant applying for enlistment. Approval authority is the CG. The Command Surgeon acts on behalf of the CG for all OCS medical waivers. Additional medical considerations for OCS that differ from normal enlistment processing are as follows:

(1) Applicants applying for OCS must meet ht/wt standards of AR 600-9 regardless of category (NPS, GNPS, and PS).

(2) Applicants applying for OCS with the inability to distinguish and identify, without confusion, the color of an object, substance, material, or light that is uniformly colored a vivid red or vivid green are disqualified (AR 40- 501, chapter 2-13e).

c. Disenrollment from prior officer candidate training exceptions, Bn must submit an exception for disenrollment from prior officer candidate training for the OCS enlistment program to EEPD Policy. Use the following for this ETP: Not to run a hard copy RE code waiver.

d. Conduct waivers.

(1) Disqualification. A conduct waiver/suitability review for OCS processing is required from CG (RA and AR), for any of the following:

(a) Any person adjudicated as a youthful offender.

(b) Any offense with a fine of \$300 or more excluding court costs.

(c) Any offense, where confinement was ordered, regardless of suspended sentence or deferred disposition.

(d) Any offense that involves contributing to the delinquency of a minor, spouse or child abuse, and any sex-related crime.

(e) Any offense, listed in AR 601-210, chapter 4, as a misconduct offense.

(f) Any alcohol related offense.

(2) Non-waiver conduct disqualification for OCS processing. Any applicant that has received any of the

following are ineligible to process for the OCS enlistment option:

- (a) A conviction or other adverse disposition for a felony offense.
- (b) Two or more convictions or adverse dispositions for driving while intoxicated, under the influence, or while impaired due to substance abuse, alcohol, drugs, or any other condition that affected judgment or driving ability. Consider without regard to technical or legal definition or term used by the State, county, or country, in which the applicant committed the offense.

M-10. WOFT Waivers

a. Age exceptions. RA applicants requesting exceptions to the maximum age for WOFT must complete a packet with a request for an exception submitted through HQ USAREC, ATTN: RCRO-SP, to Aviation Proponency, and to HQDA, Office of the Deputy Chief of Staff, G-1, ATTN: DAPE-MPO-D, Washington, DC 20310-0300. Include in the memorandum: the date of birth, Selection Instrument for Flight Training (SIFT) test score, GT score, education level, flight experience, and strong justification as to why the exception is in the best interest of the Army.

b. Medical waivers. Applicants requesting exceptions to medical entry standards must receive an aero-medical summary and recommendation for a waiver from the flight surgeon administering the Class 1 examination. Requests for waivers are submitted to the Commander, US Army Aero-medical Center, ATTN: HSXY-AER, Fort Rucker, AL 36362-5333.

c. Conduct waivers.

(1) Disqualification. Conduct waivers for WOFT processing are submitted through HQ USAREC, ATTN: RCRO-SP, to Aviation Proponency, and to HQDA, Office of the Deputy Chief of Staff, G-1, ATTN: DAPE-MPO-D, Washington, DC 20310-0300 for any of the following.

(2) Any person adjudicated as a youthful offender.

(3) Any offense with a fine of \$300 or more excluding court costs.

d. Any offense where confinement was ordered, regardless of suspended sentence or deferred disposition.

e. Any offense, regardless of disposition. That involves contributing to the delinquency of a minor, spouse or child abuse, and any sex-related crime.

f. Any offense listed in AR 601-210, chapter 4, as a misconduct offense.

g. Received four or more minor non-traffic.

h. Administrative – RE-code only.

i. Any alcohol related offense.

(1) Non-waiver conduct disqualification for WOFT. Any applicant that has received any of the following is ineligible to process for the WOFT enlistment option:

(a) Conviction or adverse disposition for a felony offense.

(b) Two or more convictions or adverse dispositions for driving while intoxicated, under the influence, or while impaired due to substance abuse, alcohol, drugs, or any other condition that affected judgment or driving ability. Consider without regard to technical or legal definition or term used by the state, county, or country in which the applicant committed the offense.

(2) HQDA G-1, is the approval authority for a conduct waiver for WOFT processing; however, Bns are responsible for obtaining the appropriate conduct waiver for enlistment purposes prior to boarding at Bn level. For example, an applicant that has one driving under the influence conviction and is applying for WOFT, the Bn Cdr must approve a conduct waiver for enlistment prior to boarding. Forward a copy of the approved conduct waiver for enlistment, as well as a Bn Cdr endorsement for conduct waiver review for WOFT processing, to HQ USAREC, ATTN: RCRO-SP, along with the completed board ready WOFT application packet and supporting documents required for conduct waiver. Special Programs and Boards Division, forwards the packet to the appropriate approving authority, HQDA G-1.

(3) Documents required in support of a conduct waiver:

(a) Company and Bn Cdr's endorsement for conduct waiver review.

(b) Applicant's detailed statement describing the circumstances of charges.

(c) All required DD 369(s), UF 601-210.02(s), and court checks.

(d) Approved Bn level waiver for enlistment (if required).

M-11. USAREC Level Reviews

a. Submit USAREC level suitability reviews, as required, by AR 601-210, chapter 4, to the EEPD Waivers Branch. This is the only official opinion used for enlistment qualification.

b. Supporting documentation: Upload in ERM all supporting court documents, LS results, police checks and incident reports, Company and Bn Cdr interviews, UF 601-210.08 (Waiver Worksheet) and applicant statement prior to submission. The same process will be followed for Bn-level actions.

c. Cdrs at levels below the approving authority, including the Company, may disapprove the review for applicants that fail to meet prescribed standards or establish a meritorious case. Capture the Cdr's recommendation in the workflow or via uploaded MFR.

M-12. Exceptions to Policy

Submit requests for ETP for qualifications and standards contained in AR 601-210 and/or REQUEST qualifications via workflow generated from GCRC. When a final disposition is received the results of the workflow are posted to GCRC. Document all approved or disapproved exceptions in the "Remarks" section of the DD 1966/4 and included in the enlistment record.

Appendix N Education Credentialing

N-1. Purpose

This appendix details requirements and processes for education credentials established by AR 601-210. The local ESS conducts school or program evaluations by completing UF 601-210.40 (School Profile Evaluation) to enter schools into HSS/FAZR database. The ESS will complete Tier Evaluation Workflows on applicants to determine and assign proper DoD Education Code classifications for applicant enlistment processing. See Figure N-1 for the education credentialing process.

NOTE: Contact G 7/9, Education Division with questions or issues pertaining to school programs, evaluation or accreditation or Tier Evaluation Workflow Process.

a. The Tier Evaluation Workflow process will be used for all applicants with education credentials from DoD Education Code "TE" schools in HSS/FAZR, and manually enter schools processing for enlistment and to request education related exceptions to policy as needed or required to determine and assign proper DoD Education Code classifications for enlistment purposes.

b. Consider regionally accredited non-public schools as established HSs that do not require a physical on-site visit to determine Tier/DoD Education Code classification. The BN ESS obtains proof of regional or legitimate accreditation and completes a UF 601-21.40 prior to inclusion of the school in HSS/FAZR.

c. Public charter schools which parallel traditional HS programs, do not require a physical on-site visit to determine Tier classification. Public charter school students who are enrolled in and/or completed a program that parallels a traditional HS program are considered in the same manner as a HS diploma graduate (HSDG) (DoD Education Code Classification L) for enlistment purposes. Charter schools in which the majority of the credit is not classroom based or exemplify alternative school characteristics require further evaluation by the Bn ESS and completion of UF 601-210.40 to establish Tier/DoD Education Code classification in HSS/FAZR.

d. All traditional public HS credentials are classified as DoD Education Code L. However, when a station commander or Company Cdr, Bn S3, or GC detects questionable credentials, refer the credential(s) to the Bn ESS for further evaluation and proper Tier/DoD Education Code classification. Public HS credentials and diplomas awarded based on testing, (GED, HiSET, California High School Proficiency Examination, Florida GED Exit Option), independent study, web and online based education, distance learning, competency based, adult basic education (ABE), or correspondence require the ESS or authorized evaluating official to determine the proper Tier/DoD Education Code Classification.

N-2. School Profile Evaluation (UF 601-210.40)

a. The ESS, or authorized official, must complete UF 601-210.40 to determine a school Tier/DoD Education Code classification on non-regionally accredited non-public schools, and all non-public adult or alternative education schools and/or programs. The information gathered to complete UF 601-210.40 is used to enter schools into the HSS/FAZR database.

b. Information to complete UF 601-210.40 can be gathered telephonically, during a physical on-site visit, via email, web site, or by written correspondence. A physical on-site visit and completion of UF 601-210.40 is required prior to coding any non-regionally accredited non-public schools, non-public adult or alternative education school as an DoD Education Code "L" or "B".

c. DoD Education Code L or B subsequent validations of such programs will be conducted every three (3) years. Schools with expired Tier Evaluations will be coded as Tier Evaluation "TE" required until a validation is completed.

d. Programs classified as Tier 2 DoD Education Code Classification E, J, or X as a result of a Tier Evaluation do not require subsequent validation every three (3) years.

e. Programs previously classified as Tier 3 will require a physical on-site visit and completion of UF 601-

210.40 to upgrade the status from a Tier 3 classification to any higher-level DoD Education Code. Validation and concurrence from the Bde ESS or G7/9, Education Division staff is required.

f. If the ESS is unavailable to conduct a physical on-site visit due to geographical dispersion, the Bn XO, the Bn S3, and Company Cdrs are authorized to complete the UF 601-210.40 and/or conduct a physical on-site visit.

g. When conducting a physical on-site visit and/or completing UF 601-210.40, recommend the appropriate Tier or corresponding DoD Education Code classification to the Bn Cdr for final approval and signature.

h. Public HSs, public continuation schools, public charter schools which parallel traditional HS programs; regionally accredited non-public HSs and is already in HSS, do not require a UF 601-210.40.

i. Tier Evaluations are the responsibility of the Bn ESS. Bn ESSs are not authorized to change Tier/DoD Education Code classifications for schools outside their Bn area. Contact the Bn ESS, Bn XO or Bn S3 within the recruiting area of operation for assistance.

j. Upon completion of the on-site school visit, the individual conducting the visit provides the recommendation in section III of UF 601-210.40, signs, and forwards it to the Bn Cdr for final approval and signature.

k. The Bn Cdr's signature is required to complete and validate the recommended Tier/DoD Education Code classification on UF 601-210.40. When the Bn Cdr is physically outside of the Bn area, a copy (email or fax) of the form is acceptable. The Bn XO, when on assumption of command orders, is authorized to sign for the Bn Cdr. (Attach a copy of the assumption of command orders to the UF 601-210.40.)

l. If a physical on-site visit and UF 601-210.40 is completed by other authorized individuals and the school/program meets DoD Educational Code L classification requirements, the Bn ESS must review and validate the form within 60 days of the visit.

(1) The ESS must maintain all completed UF 601-210.40 on file for three (3) years.

(2) If the ESS determines a school Tier/DoD Education Code classification change is required, the ESS must complete a new UF 601-210.40 and include justification in the comments section of HSS/FAZR.

(3) The Bn ESS must sign and date UF 601-210.40 in Section III to validate the recommended Tier level.

N-3. Education Tier Evaluation Workflow Process

The Bn and Bde ESSs will utilize the Tier Evaluation Workflow process IAW HSS/FAZR, the applicant's educational credential records and other substantiating educational documents to determine if an applicant's educational credentials meet AR 601-210 criteria for enlistment eligibility when a school's Tier/DoD Education Code classification listed in HSS/FAZR is "TE" and manually entered school for applicant enlistment processing or to request education related exceptions to policy as needed or required to determine and assign proper DoD Education Code classification for enlistment purposes. (See figure N-1 for the Education Credentialing Process and see figure N-2 for an Education Code classifications matrix for secondary schools.)

a. The local Bn ESS is the primary evaluating Tier Evaluation Workflow evaluating official. In the absence of the Bn ESS, the Bn XO or Bn S3 (commissioned officer or equivalent ranked civilian) acts as the evaluating official. Company Cdrs, First Sergeants or other enlisted personnel are not authorized to complete applicant education Tier Evaluation workflows.

b. The evaluating official, using the Tier/DoD Education Code classifications outlined in N-4 of this regulation, review the applicant's education documents to determine Tier/DoD Education Code classification (Figure N-2).

c. Prior to accessing individuals from a manually entered school or "TE" coded school in HSS/FAZR, the following documents are required for completion of Tier Evaluation workflow.

(1) Official transcripts from each school attended, grades 9th-12th (uploaded by the recruiter in ERM).

(2) Diploma or official transcript showing the graduation date from the school issuing the diploma.

d. Prior to accessing individuals enrolled and attending a school or program listed as manually entered school or "TE" in HSS/FAZR into the DEP or DTP, the following documents are required:

(1) Official or certified letter from the educational institution indicating date of enrollment, class attendance, expected graduation date, school transcripts for previous credits and courses completed, and the name of the school awarding the diploma if different from the school or program the individual is attending.

(2) "For DEP-In only", complete the Education Tier workflow for currently enrolled applicants by affirming the applicant's education enlistment eligibility (S, M, or 9) and the recommended DoD Education Code classification upon completion by the applicant of the currently enrolled and attending program (L, B, H or 7) is annotated as applicable.

(3) "For DEP-Out", upon the applicant's completion of the educational program (graduation), a DEP-Out Tier Evaluation workflow must be submitted and the evaluating/authorized official must reevaluate the applicant's education documents to ensure completion of the same program in which applicant was enrolled at initial DEP-In. Affirm the re-evaluation "For DEP-Out" only. Annotate appropriate Tier/DoD Education Code in the Education Tier Evaluation workflow.

NOTE: The “process Tier Evaluation” link in the applicant profile screen will remain active for those applicants who require a DEP-Out Tier Evaluation workflow

e. The evaluating official/authorized evaluating official is the approval authority for processing the Education Tier Evaluation workflow.

f. If a Tier/DoD Education Code classification evaluation is questioned by anyone within the Bn chain of command, forward the Education Tier Evaluation workflow to the Bde ESS for validation and Tier/DoD Education Code classification determination prior to applicant processing. If a decision is not reached at Bde level or below, G 7/9, Education Division makes the final determination.

g. All Education Tier Evaluation workflows will be maintained in a database server and all completed workflows will be visible in the “Completed” tab by evaluating/authorized officials.

h. All completed/previous UF 601-210.4’s and tier evaluation workflows will be maintained on file with the Bn ESS for three (3) years from date of completion.

N-4. High School Diploma Producing Programs (Tier 1)

a. High school diploma (HSD) graduate (ED LVL code 12L) (HSDG). A graduate issued a diploma or official certified copy of a transcript from a traditional private or public school. The four (4) years of secondary schooling/program of instruction (public or private) must provide education in a traditional manner (teacher- student environment, teacher directed, classroom based, day program of instruction, and required attendance. Self- paced and modular units are not teacher directed). Credits are earned based on the state, district or school standard policy for graduation requirements which vary depending on state law and the diploma is issued from the high school where the individual completed the requirements for graduation. This also includes individuals that met all requirements for graduation, but if applicable, failed to pass the state mandated exit exam(s). Graduation credentials must be issued by an institution (attendance based) approved by state/local government education agency, or accredited by one of the accrediting organizations recognized by the US Department of Education or the Council for Higher Education Accreditation, one of the following document(s) is required for verification:

(1) An official diploma or certified transcript showing the individual’s graduation date from the school that issued the diploma.

(2) Applicants not yet issued a diploma, but having met all graduation requirements, must obtain an original letter from the applicant’s principal, registrar, school guidance counselor, or custodian of records. The letter must state that the individual met all requirements for graduation but a diploma was not issued, include the reason why, and provide the completion date of high school graduation requirements.

(3) Telephonic verification can be performed by the ISG, Company Cdr, senior OPS, SGC, ESS, or equivalent contracted personnel assigned to USAREC. FSs cannot ship to training until they have received official transcripts and/or diploma that indicates they are considered a HSDG. All documents will be uploaded into the applicant/FS’s ERM

(4) Applicants, who have met graduation requirements but will not receive a diploma until financial obligations are met, must obtain a letter which explicitly states, “Diploma will not be released until all debts are cleared.” Upload the letter in ERM and request an ETP via workflow to EEPD.

b. A HS diploma earned via semester, quarter or clock hours (HSDC)/Job Corp (ED LVL code 128): A non-high school diploma graduate who completed 15 semester hours, 22 quarter hours of college credit or 675 classroom clock hours from an accredited traditional or online college or post-secondary institution. This category includes Job Corps graduates who completed at least 675 clock hours of post-secondary vocational-technical training from the Job Corps operated by the US Department of Labor and earned a GED or other Tier 2 education credential. Job Corps students must enroll in Job Corps for a minimum of 60 days prior to enlistment and are considered a HSDG:

(1) A HS diploma earned via semester, quarter or clock hours (HSDC)/Job Corp (ED LVL code 128): A non-high school diploma graduate who completed 15 semester hours, 22 quarter hours of college credit or 675 classroom clock hours from an accredited traditional or online college or post-secondary institution. This category includes Job Corps graduates who completed at least 675 clock hours of post-secondary vocational-technical training from the Job Corps operated by the US Department of Labor and earned a GED or other Tier 2 education credential. Job Corps students must enroll in Job Corps for a minimum of 60 days prior to enlistment and are considered a HSDG

(a) Credit from any post-secondary institution accredited by one of the accrediting organizations recognized by the US Department of Education or the Council of Higher Education Accreditation are accepted. Questionable post-secondary institutions require verification by the Bn ESS or authorized official.

(b) Online College credits must be on an official transcript from post-secondary institutions accredited by one of the accrediting organizations recognized by the US Department of Education or the Council on Higher Education Accreditation are accepted for HSDG.

(c) Transcripts establishing HSDC eligibility must convey the number of semester hours, quarter hours, or clock

hours acquired IAW the degree plan of the institution. Semester and/or quarter hours are accepted from any accredited degree granting institution. Clock hours are acceptable from any accredited degree and accredited non-degree granting postsecondary institution.

(d) Combining of semester hours with quarter hours or combining clock hours with either semester or quarter hours is allowed (use the formula in AR 601-210, 2-7).

(e) Combine clock hours from two or more accredited post-secondary vocational-technical schools.

(f) Do not accept or use credits for life experiences for HSDC enlistment purposes, credits earned from testing or for the pursuit of HS equivalency and credits from schools that are candidates for accreditation.

(g) Credits earned through testing, adult education, assessment, military training, or high school equivalency preparations are not applicable.

(h) Use credits awarded for online or Internet-based post-secondary courses from any degree-granting institution accredited by one of the accrediting organizations recognized by the US Department of Education or the Council for Higher Education Accreditation to establish HSDC eligibility. Online or Internet courses must be:

1. College level courses (no work or life experience courses). (See 10 below.)

2. Semester hours or quarter hours.

3. Completed before shipping to IADT.

NOTE: Use the completion of college classes numbered below 100 if the course is clearly identified as a college level course. Accept the courses for credit only if the college or university applies them to a degree producing program. Do not use college classes numbered above or below 100 that are listed as continuing education units (CEUs) or not applied to a degree-producing program.

(2) Job Corps graduates require the following: This category includes Job Corps graduates who completed at least 675 clock hours of post-secondary vocational-technical training from the Job Corps operated by the U.S. Department of Labor and earned a GED or other Tier 2 education credential. Job Corps students must enroll in Job Corps for a minimum of 60 days prior to enlistment and are considered a HSDG.

(a) The Job Corps center director and training director must verify (substitutions are not acceptable) the Job Corps Certification of Student Graduation and Completion of Vocational Training Form. The BN ESS evaluates Job Corps HS completion programs (not a GED) to ensure minimum Tier 2 education code classification requirements are met.

(b) Do not combine clock hours from Job Corps with any institution, other than another Job Corps.

c. HS diploma graduate via adult/alternative diploma (ED LVL code 12B). This includes a graduate that receives a diploma from a public or private attendance based, non-traditional school that utilizes alternative methods of instruction to complete graduation credit requirements (such as; alternative, accelerated, or HS completion programs to include the GED test option). The school or program may operate outside of a four (4) year secondary school, traditional teacher directed, credit based day program of instruction, may have flexible operating hours and utilize some type of alternative means of education (computer based, or teacher directed, and combination of testing and self-paced and or accelerated instruction). The classification of these types of schools/programs may vary depending on the state.

(1) A GED test option program is currently offered in several states as part of HS completion and is designed to target students with the capabilities to complete high school graduation requirements; but for a variety of reasons lack the credits needed to graduate with their class and are at risk of leaving school without a HS diploma. These programs are intended to prepare students for the GED test and provide substantive academic content aligned with the schools' regular curriculum and expectations. Students must attend school regularly and have access to counseling and support services. Students in a GED test option program must remain enrolled and in school and receive a HS diploma from the HS or school district and are counted as HS graduates. A minimum number of academic hours of instruction per week are provided as determined by local school districts or states to retain the classification of full-time student. The GED test scores for students enrolled in a GED test option program are only traditional academic course work. The GED score report is one of the academic components required for the awarding of a HS diploma by the local HS or school district, and as such, may be included in the student's permanent record (transcripts). Since the purpose of the GED test option program is to qualify the student for a HS diploma, the scores are only valid in that context.

(2) Do not code students who fail to complete all GED test option program requirements as determined by a local HS, school district or state as DoD Education Code B. Their status will revert to Tier 2, DoD Education Code E with the appropriate GED certificate or as Tier 3 if no valid education credentials are provided (refer to N-5a or N-6).

d. HS diploma graduate via virtual/distance school (ED LVL code 127). A secondary school graduate that, upon completion of an accredited home study, distance learning, independent study, self-study, correspondence school, Cyber School, or virtual learning program is awarded a diploma. The diploma is issued from an institution that is

either state/local government education agency approved, accredited by the Distance Education Accrediting Commission (DEAC), or accredited by one of the accrediting associations recognized by the US Department of Education or the Council for Higher Education Accreditation.

e. HS diploma graduate via home school (ED LVL code 12H). A graduate of a home school program that received a diploma IAW state requirements administered by a parent, teacher/school district, or umbrella association.

(1) To qualify for enlistment as a home school graduate, an applicant must meet one of the following criteria:

(a) In states that require parents to notify the school and/or local school district that they are home schooling their children, provide a signed enrollment form from the State Department of Education or local school district.

(b) In states that do not require parents to notify the school and/or school district that they are enrolling their children in home school, provide a home school certification or diploma from the parent, guardian, or national, state, or county home school association or organization.

(c) The curriculum used must involve parental instruction and supervision, and should closely pattern standard subjects taught in traditional HSs. Accelerated, independent/self-study, home study programs and lesson packets that award a credential or diploma based on assessment and testing are not acceptable. Do not confuse home school with independent study which may take place at home, but does not involve parental instruction.

(2) A copy of the applicant's transcript(s) for all completed secondary school grades (9th – 12th) is required. The transcripts must include an enrollment date, graduation date, and type of curriculum. Additionally, the transcripts must reflect successful completion of the last nine (9) academic months of continuous schooling from the home school or parent issuing the diploma.

(a) Further evaluation and additional verification (such as a parent letter or home school association letter) are required for all applicants attempting to enlist with only a diploma and transcript from the parents or guardian. Refer such cases to the Bn ESS for final determination. If a decision cannot be reached at Bn level, the ESS will send the packet to Bde ESS. If a decision cannot be reached at Bde level, G7/9, Education Division makes the final determination of home school credentials.

(b) Currently enrolled and attending other than a HS diploma program (adult or alternative education or post-secondary) (ED LVL code M). A non-high school graduate currently enrolled and attending class in an adult, alternative or virtual (online) education or college program other than a HSD program and is expected to graduate or attain the required credits: 15 semester hours, 22 quarter or 675 clock hours of classroom instruction within the current term. Credits from any institution accredited by one of the accrediting organizations recognized by the Department of Education are accepted. Credits earned through testing (for example, College Level Examination Program (CLEP), adult education, assessment, military training and high school equivalency preparation) are not applicable. An applicant must have a statement from the school stating he/she is currently enrolled and attending and indicates the expected graduation or completion date. Applicants attending post-secondary institutions in pursuit of HSDC status through clock hours are permitted to enlist (DEP/DTP). Process these individuals for enlistment after required documents are obtained and accomplishing proper verification procedures as established below.

f. Document and verification procedures required for applicants currently enrolled and attending in an adult education program are as follows:

(a) For DEP/DTP, an official or certified letter from the educational institution indicating date of enrollment, the date the applicant is expected to complete the program and receive a diploma, and class attendance. Utilize a MFR from the Bn ESS to verify current attendance if the college is unable to provide written verification.

(b) Upon completion from the approved adult or alternative education program, and prior to shipping for AD or for IADT, the applicant must have a diploma or certified copy of transcripts.

(1) Forward documentation that requires further review to the Bn ESS.

(2) Documents and verification procedures for applicants currently in pursuit of HSDC are as follows:

(a) An official or certified letter from the educational institution verifying enrollment in the current term (semester, quarter, or trimester) and indicates the current term completion date.

(b) Enlist individuals who have already met the minimum requirements for HSDC status under the provisions of 1(b) above, and are currently continuing attendance at an accredited institution as an HSDC credential holder. Code these applicants as COLL rather than ENRL in the REQUEST database.

(c) Individuals must have official transcripts prior to shipping for IADT. Transcripts issued by the institution stamped "Issued to Student" or "Student Copy" are acceptable.

(3) DEP/DTP members currently in pursuit of HSDC status through an adult or alternative education program or college who fail to graduate or meet the minimum 15 semester hours or 22 quarter hours of college level (post-secondary) credit are considered failed to graduate and DEP/DTP separated. These individuals are encouraged to return to school. Applicants obtaining education credentials and re-apply for enlistment qualify based on current enlistment policies.

g. HS senior (ED LVL code 11S). An individual who does not possess a valid secondary school credential (GED, HiSET or other) who is currently enrolled in a traditional, home school, online, or adult/alternative HS program of instruction and will graduate within the current authorized DEP/DTP period. An individual not in the 12th grade and enrolled in an accelerated program, must meet the requirements for graduation and complete school attendance within 365 days for RA, or 270 days (360 days for ages 17 to 18 1/2) for AR may enlist in this category. Applicants for AR must be in a full senior curriculum course of study. These individuals must have an official letter issued by the HS on official school letterhead signed by a qualified school official verifying this status.

(1) Verification is required and can be obtained in writing. It must be on the school's letterhead stationery and signed by a qualified school official (principal, vice principal, registrar, counselor, or custodian of school records, so designated by the principal).

(2) Verification is authorized by telephone or email for enlistment into the DEP/DTP. The 1SG, Company Cdr, Senior Ops Sergeant, SGC, commissioned officer, ESS, or equivalent contracted personnel assigned to USAREC can perform telephonic or email verification for enlistment. The telephonic or email verification must include name of applicant, last four of applicant's SSN, date of birth, name of school, school address, school telephone number, currently meeting graduation requirements and expected date of graduation, name and title of individual providing verification, and the name and title of individual conducting verification.

(3) Verification of senior status for all DoD Educational Code TE schools will require an initial Education Tier Evaluation workflow initiated by the recruiter. Information required will be obtained from the applicant's school principal, school guidance counselor, or the custodian of records, or registrar for enlistment in the DEP/DTP and uploaded in ERM by the recruiter. Education Tier Evaluation workflow must be completed for DEP-In only. Upon graduation, a DEP-Out Education Tier Evaluation workflow must be submitted by the recruiter and completed via the Education Tier Evaluation workflow process.

NOTE: The 'process Tier Evaluation' link in the applicant profile screen will remain active for those FSs who require a DEP-Out Education Tier Evaluation workflow.

(4) Do not change an applicant's DoD Education Code to HSDG until the applicable provisions of N-4 above are met. Advise applicants to provide the recruiter a HSD prior to shipping for IADT for GC verification of graduation. The GC then uploads the documents in ERM.

h. Currently in high school (ED LVL code 109). This applies to DTP enlistments only and HS students (other than seniors) that completed the 10th grade and are currently enrolled in a traditional, home school, online, or adult/alternative HS program of instruction. Verification must show placement into the 11th grade. Enlist the applicant into the AR ATP entering IADT Phase I after completion of the 11th grade. Verification requirements are the same as a high school senior outlined in N-4g above.

i. Applicants enrolled in accredited post-secondary universities/colleges or vocational-technical institutions. Accept degree credentials from any degree-granting institution accredited by one of the accrediting organizations recognized by the US Department of Education or the Council for Higher Education Accreditation. Degree credentials are identified below.

(1) Associate degree (ED LVL code D). A certificate conferred upon completion of a 2-year program at a community college, university, or degree-producing technical institute.

(2) Professional nursing diploma (ED LVL code G). A certificate conferred upon completion of a 3-year hospital school of nursing program.

(3) Baccalaureate degree (ED LVL code K). A certificate conferred upon completion of a 4-year college program other than a first professional degree.

(4) First professional degree (ED LVL code W). A certificate conferred upon completion of the academic requirement for the first degrees awarded in selected professions: Architecture, certified public accountant, chiropody or podiatry (D.S.C. or POD.D), dentistry (D.D.S. or D.M.D.), medicine (M.D.), optometry (O.D.), osteopathy (D.O.), pharmacy, veterinary medicine, law (L.L.B. or J.D.), and theology (B.D.), rabbi, or other first professional degree.

(5) Master degree (ED LVL code N). A certificate conferred upon completion of additional academic requirements beyond the baccalaureate or first professional degree but below the doctorate level.

(6) Post-Master's degree (ED LVL code R). A certificate conferred upon completion of additional academic requirements beyond the master degree level but below the doctorate level.

(7) Doctorate degree (ED LVL code U). A certificate conferred in recognition of the highest academic achievement within an academic field, excluding honorary degrees and first professional degrees.

(8) Refer questions on accreditation or coding to the Bn ESS.

N-5. Alternate HS Credentials (Tier 2)

The alternate category includes the HS equivalency credentials (GED, High School Equivalency Test (HiSET)),

National Guard Youth Challenge Program (NGYCP), and High School Certificate.

a. Test-based equivalency diploma (Ed LVL code E). A state or locally issued secondary diploma or certificate of GED/HiSET or other test-based credential obtained solely on the basis of testing and not graded day course work. This includes statewide testing programs such as the California High School Proficiency Examination where an examinee may earn a certificate of competency or proficiency.

b. High school certificate of attendance/completion of special education (ED LVL code J). An attendance-based high school certificate issued based on an Individualized Education Program (IEP) that involves community experiences, employment, training, and/or daily living skills which differs from traditional high school graduation requirements.

c. High school graduate via National Guard Youth Challenge Program (NGYCP)/General Education Diploma (EDLVL code X). An individual who has completed a National Guard Youth Challenge Program and received a National Guard Youth Challenge diploma. This test-based credential differs from other GED holders in that the GED certificate or other test based credential was issued based on enrollment and attendance of a 22-week NGYCP and passing the GED test. Applicants must complete both the NGYCP and GED to enlist as a Tier 2/DoD Education Code classification X.

(1) Evaluate graduates of NGYCP which have embedded educational programs meeting Tier 1/DOD Education Code classifications and/or awarded a HS diploma other than a GED based NGYCP diploma as an Education Tier Evaluation workflow to determine proper Tier/DoD Education Code classification.

(2) If further investigation is required, forward questions and documentation via email to G7/9, Education Division for a case-by-case determination.

N-6. Less than an HSD (Non-High School Diploma) (Tier 3)

Less than an HSD (ED LVL code 1). An individual who is not currently in a secondary education program and does not possess a diploma/credential as listed above. Diploma mills/degree mills are non-accredited organizations claiming to be an institution of learning (Secondary and Post-Secondary), but exist for profit only and offer degrees, diplomas, or certifications for a fee that may be used to represent to the general public that the individual possessing such a degree, diploma, or certification has completed a program of education or training, but little or no education or course work is required to obtain such a degree, diploma or certification. These types of programs will be classified as Tier 3. Schools classified as Tier 3 or determined to have had previous education improprieties require re-evaluation, by the Bn/Bde ESS or G7/9, Educational Division. Enter schools identified as Tier 3 into the HSS/FAZR database with the proper DoD Education Code classification with justification in the comments section. (Refer to N-2e.)

N-7. Credential Laundering

a. Recruiters are strictly prohibited from participation in credential laundering activities. Credential laundering is defined as "recruiter advice or assistance provided to an applicant or prospect for the purpose of, or which has the effect of, converting or transferring a Tier 2 credential to a Tier 1 credential solely for the applicant or prospect to meet the Army's Tier 1 education enlistment requirements." This includes:

(1) Transporting applicants to education institutions except to obtain HS letters, diplomas, or other required documents for the enlistment packet.

(2) Assisting applicants in registering in any education program or institution for the purpose of qualifying for enlistment and initiating involvement with school officials for the purpose of developing a HS/alternative degree completion program.

(3) For additional prohibitions see chapter 7 of this regulation.

b. Realizing the difficulty recruiters face in scrutinizing the instructional methods used by public schools in their various educational programs, questionable HSDs will be referred to the Bn ESS for further evaluation and proper Tier/ DoD Education Code classification prior to acceptance.

Figure N-1-Tier Evaluation Workflow

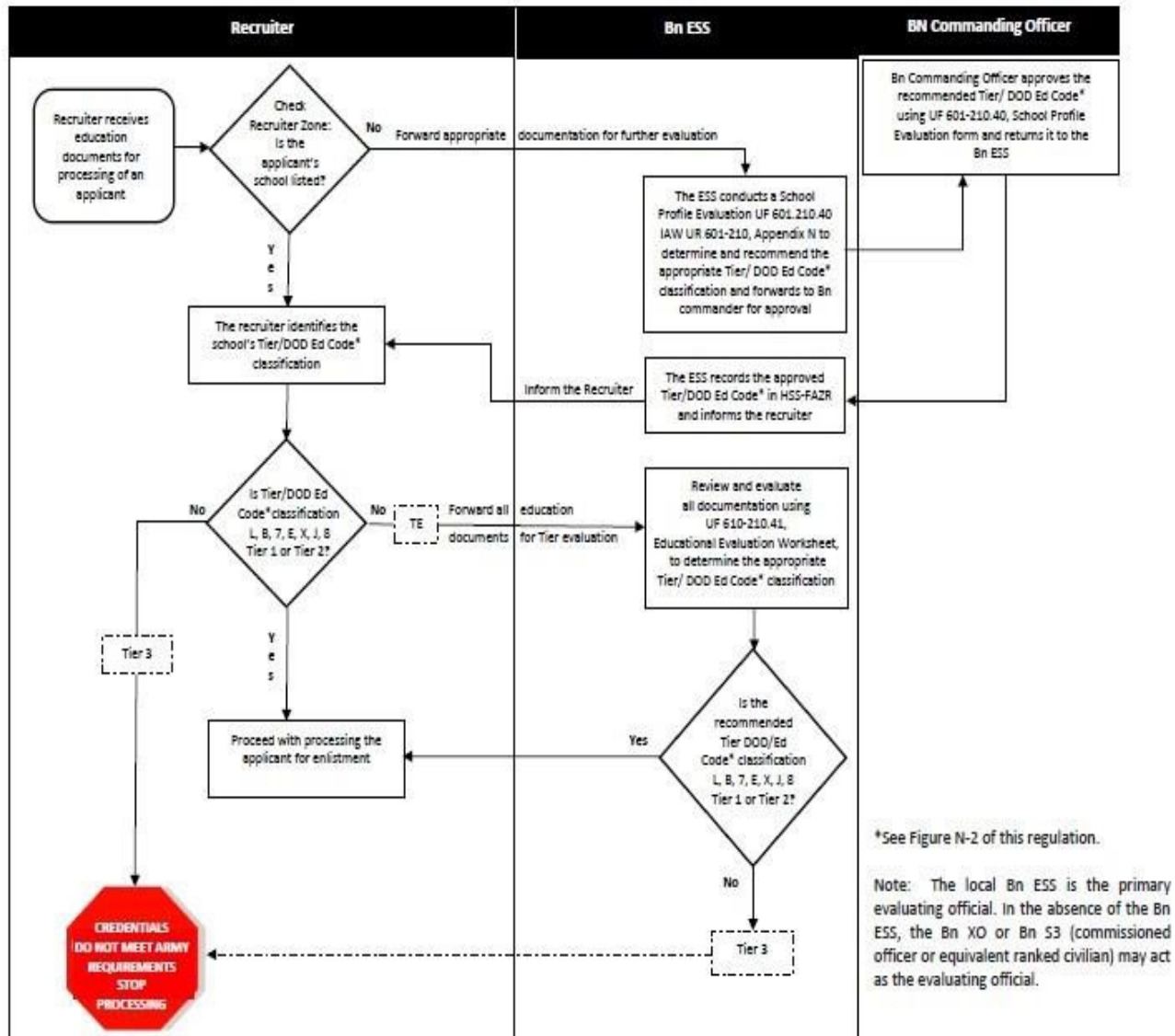

Figure N-1-Tier Evaluation Workflow

Figure N-2-Education Matrix

EDUCATION					
Credential	Ed Code	Tier	Definition	Required verification	Juniors/Seniors (109/11M/11S)
Currently in High School (CHS)	109	1	An individual currently in high school who is not yet a high school senior. This includes Adult Alternative, Online high school and Home School (Covered Grads).	HS letter or telephonic memo specifying applicant is a junior, beginning and last day of current year classes, first day of next year classes, and projected graduation date. Permission to ship early and/or return late must be on school letterhead, not telephonic, and also be accompanied by a parental letter also giving permission. Confirmation from the high school official that the school is aware the student will return after the beginning of school and will not be penalized due to military training and must also include the number of days the student may miss and must state the specific date that the student will be released during his/her junior year in order to attend training. The high school letter will also state the end date of the junior year, beginning and expected graduation date.	Not Applicable
High School Senior**	11S	1	An individual attending high school, who completed the junior year and is a high school senior. This includes Adult Alternative, Online high school and Home School.	HS letter or telephonic memo indicating applicant is a senior, and projected date of graduation, which must be within 365 days. Mid-term grads; must have a letter stating the applicant is currently enrolled and in good standing will be classified as High school graduate upon completion of all required courses.	Not Applicable
Currently Enrolled other than High School Diploma	11M	1	An individual who is currently enrolled and attending class in a tier 1 category (credential) other than a High School Diploma (college or Job Corps). Enlistment is authorized under education code currently enrolled (M) for applicants using online college credits. All online courses must be validated prior to enlistment.	Letter of enrollment from college or telephonic memorandum verifying applicant is currently enrolled, attending, and verifying number of quarter/semester hours for which enrolled. Applicants enlisting (DEP-In) as 11M will be required to complete the program in which the program in which enrolled prior to DEP Out. Future Soldiers (FS) who fail to graduate or complete the program will not be allowed to ship as Tier 2.	Not Applicable
High School Diploma	12L****	1	A diploma issued to a graduate of a public or private 12-year, "traditional," credit-based day program of classroom instruction. Includes individuals who met all requirements for graduation but failed to pass mandated exit exams (formerly Code F).	HS diploma or certified transcripts showing actual date of graduation.	11S and 109
Completed One Semester of College/Job Corp	128	1	A non-high school diploma graduate (i.e., tier 2 credential holder) who attended and completed 15 semester hours of college credit or 22 quarter hours of college credit or 675 clock hours of classroom instruction from an accredited post-secondary institution. Credit earned through testing, adult education, assessment, military training or high school equivalency preparation is not applicable. This includes Job Corps.	College Credit: Certified transcripts verifying number of clock, quarter, or semester hours completed is required. Job Corps applicants must provide verification of program completion of 675 hours signed by Center Director and Training Director, as well as GED or HS diploma to enroll as a 128. The use of online college credits to establish HSDG via semester hour or quarter hours from any degree granting institution recognized by the United States Department of Education or the Council for Higher Education Accreditation. Eligibility for the use of any online credits must be: 1. College level courses (no remedial courses, work, or life experience). 2. Semester hours or quarter hours (no clock hours)	11M

Figure N-2-Education Matrix

Figure N-2-Education Matrix (Con't)

Virtual/Distance School (Covered Grad)	127	1	A diploma awarded upon completion of an accredited Home Study, Distance Learning, Independent Study, Self-Study, Correspondence School, Cyber School or Virtual Learning Program. The Army will accept al diploma issued from an institution that is either state/local government education agency approved, accredited by the Distance Education Training Council (DETC) or accredited by one of the accrediting organizations recognized by the United States Department of Education or the Council for Higher Education Accreditation.	HS Diploma issued from an insitution which is listed as Virtual/Distance school in HSS. The BN Education Services Specialist (ESS) is the primary evaluating official for all tier evaluations (UR 601-101). UF 1015-A will be completed on applicants from public and non-public and adult or alternative education programs listed as Tier Evaluation (TE) in HSS-FAZR.	**11S and 109
Home School Diploma (Covered Grad)	12H	1	A diploma issued to a graduate of a home school program in accordance with state requirement, administered by a parent, teacher/school district, or umbrella association. Applicants must provide a diploma or certificate and transcripts indicating the individual completed four years of a high school curriculum. Transcripts must reflect successful completion of the last 9 academic months of continuous schooling from the home school umbrella association or parent issuing the diploma. The curriculum must involve parental instruction, supervision and should closely pattern subjects used in traditional high schools.	HS Diploma/Certificate and transcripts confirming four years attendance and graduation IAW state requirements. The BN Education Services Specialist (ESS) is the primary evaluating official for any required tier evaluations (UR 601-101).	11S and 109 (do not use 11H)
Test-Based Equivalency Diploma	11E	2	A diploma or certificate of General Education Development (GED) or other test-based credential. A state or locally issued secondary school diploma obtained solely on the basis or testing and not graded day coursework.	General Education Diploma or certificate; HiSET and TASCexam states: http://hiset.ets.org/requirement or http://www.tasctest.com/test-center-locations-for-test-takers.html . Applicant must be 17 years of age to process under education code "E".	Not Authorized
National Guard Youth ChalleNGe Program	12X	2	An individual who completed a 22 week National Guard Youth ChalleNGe Program (NGYCP) and passed the GED. Must be identified separately from other GED holders.	National Guard Youth Challenge Certificate and GED. Note: Applicants from NGYCP authorized by the state to award adult HS diploma (see 12B).	Not Authorized

Figure N-2-Education Matrix (Con't)

Appendix O

Future Soldier (FS) Management

O-1. Purpose

- a. Outlines procedures to manage FS from the time of enlistment until the FS accesses onto AD or IADT. FSs are persons who have enlisted in the DEP or DTP and have not shipped.
- b. Provides guidance for FS initial orientation, management and training.
- c. The Future Soldier Training Program (FSTP) is the primary introduction to the Army and provides the basic core knowledge required to prepare the FS for the rigors of Army life and keeps them qualified, committed, and eager to serve in the Army.
- d. The FSTP is a command responsibility at all levels. Key tasks for the chain of command include accountability, training, counseling, mentoring, retention and preparing the FS for training.

O-2. Future Soldier Orientation

The commitment of each FS is highest immediately after enlistment. Station commanders or designated representatives, meet with each FS following their enlistment. Recruiters review the FS enlistment documents or any other items in ERM. This provides the opportunity to answer any questions the FS has about the enlistment, shipping or the military. Brief any minors with their parents present (if possible) and the presence of the influencers of any FS is essential to engender influencer commitment and answer questions. Utilize the Initial Orientation section of www.futuresoldiers.com to guide the discussion and cover the following topics:

- a. FSTP functions. Stress the importance of attending these functions and the opportunity to bring a guest. Provide all FSs the training schedule with all functions and training annotated.
- b. Assist the FS establish an ARS-SMART account. The purpose of the referral program is to generate new contracts from members of the FSTP and applicants processing for enlistment. Establish the ARS-SMART account IAW the instructions found on <http://www.usarec.army.mil/support/> and explain the importance of the account. Ensure the FS understands the referral process and how referrals may result in advanced enlistment rank under the provisions of AR 601-210.
- c. Personal readiness. Recruiters will emphasize the importance of maintaining mental, physical, and conduct readiness prior to BCT.
- d. Family support. Provide the spouse, parents, Family members or other key influencers information and materials developed to assist in support initiatives. Introduce and familiarize spouses and parents to online community support opportunities available through the Family Information Center (FIC). Inform Family members about the Family member link on the top of the FS home page and of the U.S. Army Future Soldier Family Facebook links so they can learn more about the Army and share common interests, concerns and questions with other FS Family members.
- e. Brief new FSs about the Hometown Recruiter Assistance Program (HRAP) and that they are eligible for consideration for HRAP duty while in AIT or after arrival at their first duty station.
- f. Verify the NPS FS received a FS Welcome Kit (RPI 200) from the GC shop on day of enlistment.

O-3. Future Soldier Center (FSC)

- a. The USAREC FSC augments the recruiting force in the operation of a successful FSTP. The FSC does not take the place of the station, but provides an additional line of communication between recruiters, FSs and influencers. The FSC personnel's military background allows them to relate easily to FSs, spouses and Family members, to address questions or concerns.
- b. The FSC communicates with FSs by email, telephone, and the FS chat room accessible through www.futuresoldiers.com. The FSC often identifies potential ship issues, and immediately shares this information with the FS's station commander and Company Cdr. FSs can contact the FSC for assistance by calling 1-866-534-5297.
- c. FSC activities assist in sustaining FS motivation and commitment to ship. Activities include:
 - d. Cyber Squad. FSs are offered opportunities to enroll in MOS specific groups. These cyber squads link to online social communities that promote learning about their chosen MOS. FSs meet and interact with their future BCT teammates from across the nation prior to ship day.
 - (1) Chat room. Chat events range from a general forum available to all FSs to specialty chats that allow them to interact directly with drill sergeants or cadre members for various training facilities across the Army.
 - (2) Family Information Center (FIC). Married FSs are contacted directly by an FIC representative whose primary focus is in support of the spouse in order to facilitate a smooth and informative transition from the civilian to Army Family. Contact actions are accomplished through a combination of telephone, email and online social

community interactions. FS spouses and parents may contact the FIC by calling 1-877-535-6387.

e. Each spouse is provided an opportunity to voluntarily enroll in the FIC online forums where they will have the ability to ask questions and interact with FIC staff directly as well as other new Army spouses. Common issues include pay, moving, family housing, and enrollment in the Defense Enrollment Eligibility Reporting System (DEERS) and TRICARE, to name a few.

f. The FIC also contacts the parents of the FS to provide them with Family information as well as allow them also the opportunity to enroll on a parent's side of the online community. The forums invite parents to ask questions of FIC staff and to communicate with other FSs' parents before, during and after their new Soldier ships to basic training. Common questions include, mailing information, graduation and family day information and where to view training installation online updates.

(1) In addition to the activities above, the FSC handles all FS inquiries IAW USAREC policy and provides a welcome letter to the FS. The enlisting station and Company Cdr are included on the return correspondence.

(2) In the event of a natural disaster, the FSC stands ready to assist in FS accountability. The FSC contacts Bns and companies potentially affected by such events and offers assistance in contacting assigned FSs as well as disseminating critical information deemed necessary by the local level Cdrs.

(3) Direct Unit Support. The FSC augments FS follow-up by contacting recruits via phone and e-mail. The FSC can devise a contact program tailored to the needs of the local Cdr through custom survey questions and providing the responses directly to the Cdr.

(4) Facebook. The FSC maintains a FSC Facebook page providing real time information and discussions as well as an online location for FSs to meet and congregate. Located on the FSC Facebook page, tabs are available for both FS spouses as well as parents that contain information and offer links to interactive online help and support.

O-4. AR Sponsorship

a. Recruiting personnel assist AR TPUs maintain their strength. The enlistment of a new AR soldier presents an opportunity to enhance the special relationship between stations and TPUs. The AR Sponsorship Program formally recognizes this relationship and allows recruiting personnel to act as ambassadors for the units.

b. Program processes: The station notifies the TPU when a new AR Soldier enlists and sets a date for the recruiter to escort the Soldier to the unit. The appointment is scheduled with the unit administrator, commander, first sergeant, or unit career counselor who is responsible for in-processing new personnel.

c. Recruiting personnel utilize UF 601-210.23 (FS Advanced Rank Verification) to document the FS's completed training tasks. The station commander will complete their portion of UF 601-210.23, get the Company Cdr's signature to validate, and then forward to the TPU Cdr as a source document for promotion on each FS qualifying for an advanced enlistment rank (IAW AR 601-210, chapter 2-18). The UF 601-210.23 and associated promotion documents (DA 4187) are uploaded in the FS's ERM.

O-5. Future Soldier Sustainment

Utilize the Army Pocket Physical Training Guide RPI 237 for the four training schedules to provide the baseline for FS Physical Training (PT).

a. Prior to conducting any type of PT, recruiting personnel conduct risk assessments and maintain the DD 2977 (Deliberate Risk Assessment Worksheet) completed IAW UP 385-10 (USAREC Safety). Execute the PT session IAW guidelines listed in the RPI 237, which complies with Army Physical Readiness Training (PRT).

b. Recruiting personnel will require each FS to sign UF 601-210.24 (FS Physical Training Program Statement), prior to each organized PT session. Recruiting personnel will explain that by signing the form, the FS indicates that their participation in the event is voluntary. Participants must understand that no medical coverage is afforded to the FS. They will be informed that they must rely on their own medical plan for health care in case of illness or injury during any activity to include pre-initial military training PT and the diagnostic APFT.

c. Review of UF 601-210.27 (Medical Safety for FS Physical Training Program and Physical Fitness Assessments). UF 601-210.27 provides the recruiter with items that should be considered and symptoms of heat injuries that may arise during the performance of these physical activities. Any sign of heat-related injury noted on the form will be cause to immediately cease the activity.

d. Utilize RPI 237 for the four (4) training schedules. These provide the baseline for FS PT. FSs are assigned a training schedule based on the individual's physical strengths and conditioning.

e. Physical Training (PT)

(1) Organized PT builds morale while working on the overall goal of getting the FSs to pass the APFT. Recruiting personnel will not use PT to replicate BCT or IADT conditions.

(2) Esprit de corps PT may consist of non-contact team sports such as soft ball, touch or flag football, volleyball, and basketball. Physical conditioning exercises may also be used instead of or in combination with team

sports.

(3) The CG authorizes FSs to voluntarily participate in PT with recruiting personnel under the following guidelines:

(a) Each FS must read and sign UF 601-210.24.

(b) The training period should last no longer than 90 minutes to include warm-up and cool-down activities.

(c) Although FSs participate voluntarily, remind them that PT is an individual responsibility. Encourage FSs to follow their individual training plan as outlined in RPI 237.

O-6. Future Soldier Follow-up

a. Aggressive and professional follow-up is essential to FS management. Recruiters must rely on face-to-face or telephonic contacts and not solely on email or social media. Cdrs must stress the importance of scheduled follow-up with their FSs. Recruiters discuss, at a minimum, mental, physical, and conduct readiness. Additional topics include new referrals, status of past referrals, and up-coming events, such as FSTP functions. Utilize follow-up contacts to reinforce the FS's decision to enlist in the RA or AR.

b. Follow-up and commitment reinforcement begins at the conclusion of the swearing-in ceremony. This is accomplished in an appropriate setting with congratulatory remarks made by the SGC or other recruiting personnel. Address the new FS as Private (Private Smith, Jones, etc.). The GC explains to FS that they are now a private in the AR (in an inactive status), and prior to shipping they will swear into the RA. For new AR FSs explain that they are members of the specific TPU and when they ship to IMT.

c. Leverage all available technology for FS follow-up. Recruiting personnel must identify the FSs preferred method of communication and use it when updating the FS on coming events. Twitter, Google+, and Facebook are all authorized methods. Validate if the FS can receive text messages and cell phone calls. The FS bears all incurred costs of text messaging or cell phone calls if that is the preferred method. Identify alternate means of communication if cellular or internet is not available to the FS.

d. Stations will refer to Figure O-1 (FSTP Decision Matrix) for guidance on the sequential order of tasks to be accomplished prior to shipping to IMT.

e. Record the results of follow-up are recorded in the FS's record, under "contact history".

f. There will be instances of FSs losing their motivation to ship or becoming disqualified while in the FSTP. Depending on the circumstances, a recruiter will use all available means in order to re-engage the FS's commitment. If the FS loss is unavoidable, the recruiter will immediately notify the station commander/Company Cdr and initiate FS separation procedures IAW appendix I.

O-7. Future Soldier Asset Inventory

a. The Company Cdr will conduct two Future Soldier Asset Inventories (FSAI) on each FS. The first at 60 days from ship day, with the second at 30 days from ship day. This FSAI is designed to identify potential ship issues while there is still time to prevent a FS loss.

b. The Company Cdr will initiate the FSAI using the questions listed in Table O-1. All answers that indicate the FS is not ready or able to ship to training, will be documented in the "Comments" section of the FS record in LZ. The FS ship potential will then be updated, based upon the criteria listed in Table O-2.

c. Cdrs will report the FSAI contact percentages and results to Bn Ops on a monthly basis.

Table O-1: Future Soldier Asset Inventory (FSAI)

<p>Future Soldier Asset Inventory</p> <p>Do you have any questions or concerns regarding your enlistment contract?</p> <p>Have you met all requirements to obtain your diploma or degree?</p> <p>Have you been treated or have been seen by any medical professional for any reason since you joined the US Army?</p> <p>Have you taken or been prescribed any new medications sine you have enlisted?</p> <p>Have you given your notice to your civilian employer?</p> <p>Is your family prepared for your departure to IADT?</p> <p>Have you had any dealings with law enforcement since your enlistment into the Future Soldier Program?</p> <p>Have you received any new tattoos since your enlistment into the Future Soldier Program?</p> <p>If Army Reserve, have you fully processed into your Army Reserve Unit?</p> <p>Has your marital status, dependency status change?</p> <p>If your ship day was tomorrow, would you be prepared to leave?</p>

Table O-1: Future Soldier Asset Inventory (FSAI)

FIGURE O-1. FSTP Decision Matrix

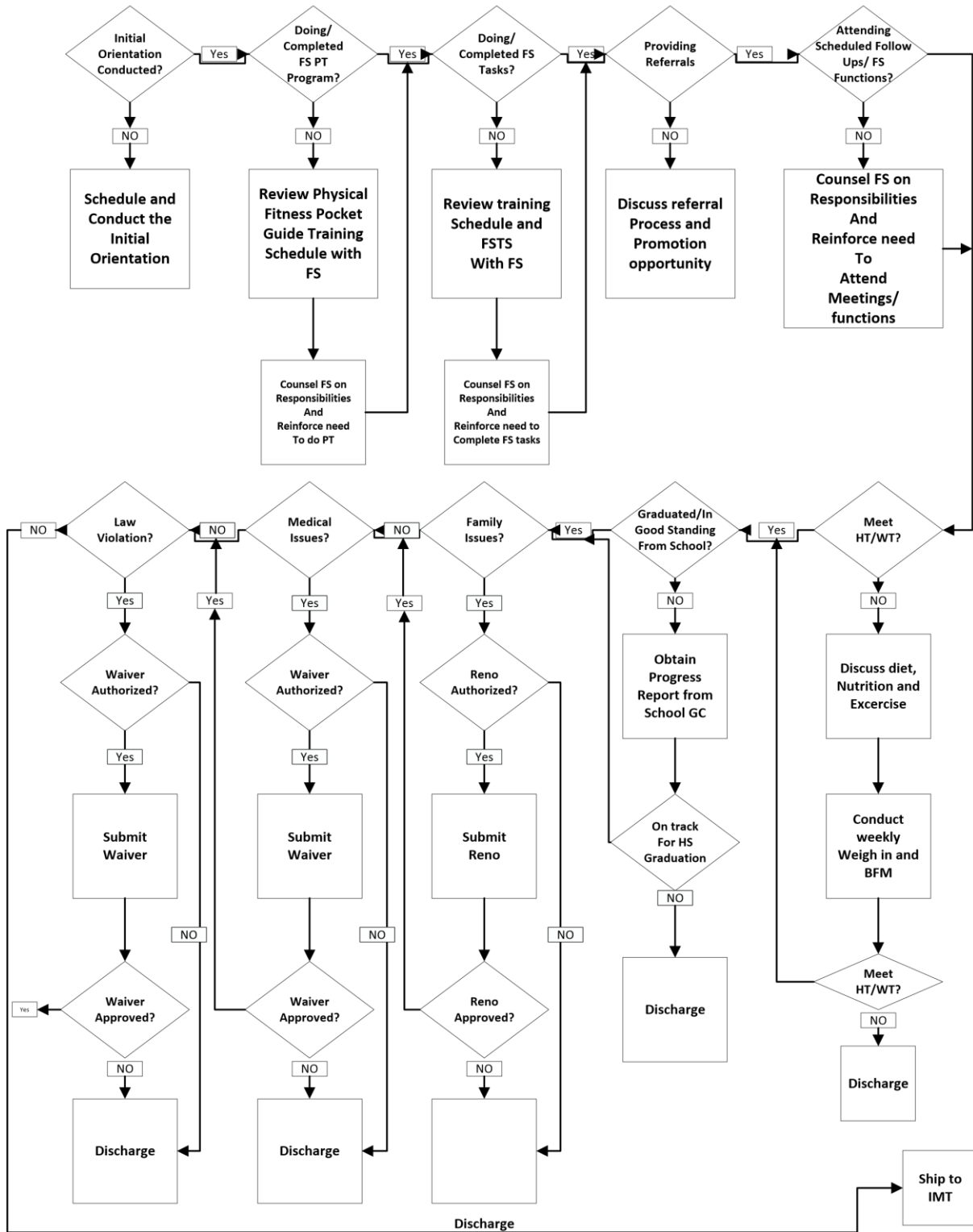

FIGURE O-1. FSTP Decision Matrix

O-8. Future Soldier Training

a. Station commanders ensure that FSs are trained on the Leader Based training tasks. Classes are available on the “Recruiting Operating Functions Guidance” tab on IKROME <https://span.usarec.army.mil/sites/HQ/G3/Plans-Programs/Programs%20Library/Forms/AllItems.aspx> . Leader Based Training consists of:

- (1) SHARP/Unauthorized Relationships (Requirement)
- (2) Army Suicide Prevention - ACE
- (3) Resiliency Training Phase I
- (4) Resiliency Training Phase II (5) Resiliency Training Phase III

b. The Required Training (Basic Training Task List-BTTL) (only required for advanced enlistment rank), is on the “Required Training” Tab in the Future Soldier Training System (FSTS). These classes assist the FS in preparing for the challenges they will face in IMT. BTTL tasks include:

- (1) Army Values and History
- (2) First Aid
- (3) General Orders
- (4) Land Navigation
- (5) Customs, Courtesies, and Traditions
- (6) Military Time
- (7) Phonetic Alphabet
- (8) Rank Structure
- (9) Voice Communication

c. Additional classes located on the FSTS are:

- (1) Anti-Terrorism
- (2) Combat Trafficking in Persons
- (3) Drill and Ceremonies
- (4) Equal Opportunity
- (5) Equipment of the U.S. Army
- (6) Personnel Recovery
- (7) Risk Assessment
- (8) Financial Management

d. The FS may elect to train virtually via the FSTS located at www.futuresoldiers.com. The FSTS is a self-paced training program that the FS accesses with their GoArmy user name and password from any computer with internet capability. The FSTS is designed to assist the recruiter in tutoring the FS, giving the recruiter back valuable time to prospect and process. The FSTS does not replace one-on-one mentorship. Recruiters may elect to train the tasks individually or in a group setting and use the FSTS to reinforce their collective training.

e. FSs successfully completing the BTTL, the APFT (60 points in each event), and provide a qualified referral who enlists in the AR, RA, or ARNG, may qualify for advanced promotion to E-2 under the provisions of AR 601-210.

f. Station commanders will complete the UF 601-210.23 and forward it to the Company Cdr for verification and digital signature.

O-9. Management of FSTP Functions

a. Conduct all FS training IAW AR 350-1. Download training material from IKROME, "Important Links" tab, “Recruiting Functions” link, “FSTP” tab and through the FSTS.

b. Procure FSTP functions IAW policies and procedures established by the servicing contracting officer AR 601-2, chapter 6, establishes Army policy for use of Government funds for FSTP functions.

c. Use the funds established in support of FS programs to pay for meals, refreshments, and nonalcoholic beverages (see below). The approval authority for FSTP functions (below \$2,500) is the Bn Cdr.

(1) Costs between \$2,500 through \$ 3,000 require advanced approval from the Bde Cdr.

(2) Bdes must submit a DA 3953 (Purchase Request and Commitment) through the USAREC, G4, Acquisitions Division, for any event over \$2,500.00.

(3) The ACS, G8 is the approval authority when the cost is expected to exceed \$3,000 or \$15 per person.

(4) Company Cdrs can order Meals, Ready to Eat (MREs) for FS functions using UF 601-210.26 (Future Soldier Training Function Request and After Action Report) IAW UR 700-5 (Integrated Logistics Support).

d. All requirements containing services such as transportation (busses) or catered meals require Acquisition Management Oversight (AMO) approval as required by TRADOC Regulation 5-14.

e. Any event scheduled to take place at a restaurant with wait staff requires AMO approval. Schedule functions only with restaurants, or other vendors, that agree to charge only for the number of meals served. In exceptional

cases, the Bn Cdr may approve payment for meals provided but not consumed. Government payment is not made for meals in excess of those contracted originally.

f. Prohibited activities:

(1) Only recruiting personnel, military and DoD guests, and FSs and their non-military or non- DoD guests are authorized funded meals and/or snacks at FSTP functions.

(2) Funds are not authorized for entertainment (such as tickets to sports events, amusement parks, theme parks, etc.)

(3) Train only general military subjects (for example; first aid, phonetic alphabet, general orders, etc.).

(4) Under no circumstances will activities with FSs include any of the following:

(a) Firing weapons of any kind, including hand guns, rifles, live grenades, artillery, cannons and rocket launchers.

(b) All overnight activities such as hikes, outings, and canoe trips.

(c) Adventure type training involving risk of physical injury, such as river rafting, rappelling, scuba diving, obstacle courses, paint ball, or similar activities.

(d) Taking FSs on tactical field training exercises with RA, ARNG, or AR units unless for observation purposes with proper permission from the unit only.

(5) Total Army Involvement in Recruiting (TAIR) assets may be used in conjunction with FSTP functions and/or meetings. For details see UP 601-2-1.

(6) USAREC G-3 is the approval for ETPs for FS functions or training. ETP approvals are required prior to the scheduled event.

g. FSs are encouraged to bring guests to FSTP functions. Guests may include eligible prospects, parents, a spouse, girlfriend or boyfriend, or close relative.

h. Procedures.

(1) The station commander will determine the number of attendees for FSTP functions and relay them to the Company Cdr. Ensure invitees have been notified and that reminder calls are made so meal counts can be confirmed and adjusted with the vendor.

(2) The Company Cdr will initiate requests for FSTP functions. Requests are sent to the Bn Cdr on UF 601-210.26.

(3) Upon receipt of a request for function, the Bn Cdr will evaluate the request. The Bn budget and accounting technician will ensure that no sales tax is paid when using the Government Purchase Card (GPC).

(4) If the Bn Cdr does not concur with the need for the function, the Bn Cdr will indicate disapproval in block 12 and sign block 15c of UF 601-210.26, notifying the Company Cdr of the disapproval.

(5) If a request for a high-cost function is approved by the Bde Cdr (and by HQ USAREC), the Bn Cdr will begin procurement procedures upon receipt of the approval and the Bde control number. When G3, Programs Division, receives a request from a Bde for approval of a function exceeding \$3,000 or expected to exceed \$15 per meal or snack per FS guest, the request will be expeditiously evaluated and prepared, preferably within 3 working days, either approving or disapproving, by endorsement before sending the request to the G4 Acquisitions Division.

(6) MREs are authorized at any FS function and are requested using UF 601-210.26 IAW UR 700-5.

(a) Station commanders will initiate a request for MREs via email to the Company Cdr. Requests must be submitted NLT 90 days prior to the function start date.

(b) MREs shipments via FEDEX are sent directly to the recruiting company for distribution. MREs are only for FSs. Recruiters, Family members, and other civilian COIs or VIPs are prohibited from receiving MREs.

(c) Account for MREs requested for use at functions by the Signature Headcount Sheet, DA 3032. Check the Dinner Category (block 5) "Other" with "Future Soldier Function" placed on the following line. Personnel receiving MREs will sign block 6 (signature) and place the last four digits of their SSN in block 7 (meal card number).

(d) After the FSTP function, the Company Cdr will collect any residual MREs and supporting documentation (UF 601-210.26 and DA 3032). Forward the supporting documentation to the Bn S-4 for accountability. Upon receipt, the Bn S-4 will contact the Bde S-4 for remaining MRE disposition instructions.

(e) When MREs are used in conjunction with a funded function, annotate UF 601-210.26, block 18 (Remarks) with the number of MREs consumed. When MREs are used at unfunded functions place "US Army" in block 7, both block 8f and 8g will reflect "NA"; and place "NA" in block 24 in both actual cost and cost per person of UF 350- 10.5. All other sections of this form must be completed IAW regulatory guidance.

Table O-2 FS Status Code Examples

Color	Examples
Red	Significant life changing event (scholarship, inheritances). Pregnancy. Excessive weight gain; failing BF% Non-waiver able medical condition; non waiver able law violation. No contact. Failure to meet graduation requirements (attendance, grades).
Amber	Poor attendance at school Overweight or underweight Changes in dependent status Changes in employment status Avoiding follow-ups with recruiter.
Green	Member in good standing of all classes (secondary and post-secondary) Performs PT and tracking accomplishments; completing FS tasks. Ready to ship. Solid Commitment. Regularly provides referrals. Regularly attends FSTP functions.

Table O-2 FS Status Code Examples

Appendix P DEP/DTP-Out Procedures

P-1. Purpose

This appendix provides a systematic approach for accessing Future Soldiers into the RA and AR through the DEP-out procedures at shipping.

P-2. General

Complete DEP-out procedures IAW this appendix and AR 601- 210, chapters 5 and 6.

P-3. Procedures

a. Upload and review the DD 2807-1 and the updated DD 2808 with DAT and HIV results and UMF 40 series for any additional medical information revealed during the packet inspection.

b. Review the FS's MOS and option(s) to ensure all qualifications are accurate, to include the OPAT PDC.

Review, sign, upload and save the following:

(1) DEP-out annex.

(2) DD 1966 series, to include all required statements in Section VI, Remarks section.

(3) UF 601-210.13 (Loan Repayment Program in Processing Counseling), if applicable.

c. Conduct a personal interview prior to printing the DD 1966/1 with the FS to ensure proper documentation is in the enlistment record (any changes during DEP- in).

(1) Review the personal data on the 680-3ADP screen in GCRc.

(2) Verify the processing of valid FS promotion to a higher enlistment pay grade.

(3) Validate the FS has a Government issued photo ID in his or her possession prior to accession.

(4) Upload any additional documentation provided by the FS to substantiate changes in the enlistment record.

(5) Validate the legible upload of any FS dependent; marriage certificates, birth certificates, SSCs, unexpired spouse photo ID, divorce decrees, court order (as applicable).

(6) Validate SF 1199A is completed, signed by institution representative, and FS has ATM card or checkbook.

(7) Verify the accuracy of the following:

(a) Updated MEPCOM 680-ADP uploaded in ERM

(b) Original DD Form 2808 with DAT and HIV results, DD 2807-1, DD 2807-2, and any other medical documents.

(c) FP submission and results

(d) Security Investigation submission and acceptance

(e) Validation of MOS qualifications

(f) Review of the Difference Report for changes in the record

(g) Any other official forms/documents required by appendix E.

d. Review DD 1966/1, items 18-19, for proper codes IAW AR 601-210, 6-12 and figure 6-1.

e. Complete and sign the ship annex for the enlistment option(s) and program(s) selected.

f. Verify tech check results and the background investigation submission.

g. Provide required documents to MEPS only if required IAW local MEPS SOP at the time the FS ships to IADT, training, or permanent party.

h. Upload ship documents in ERM; DD4 series reflecting accession, DD 93, travel orders, updated 680ADP, etc.

i. Confirm ship in REQUEST.

j. Either the GC shop or Bn Ops will clear all processing out of the Pending DEP Confirm, Pending ENL Confirm and Pending SHIP Confirm tabs as soon as the action occurs or by 1500 EST

NOTE: When an AIT is not conducted at an Army installation, PS/GNPS and Phase II Split Option, ATP Soldiers are sent to the nearest Army Reception Battalion listed in Table F-2.

k. Ship confirm that is completed on accident will be submitted through workflow to EEPD. BN OPS will request an unlock and explain why the ship confirm was accidental.

P-4. Courtesy Shippers

a. GCs review the FS record for all qualifications for the enlistment options and programs selected and confirm the proper completion of all documents. The following actions will be taken:

(1) Enlisting station commander, or designated representative, will:

(a) Upon notification that a FS is requesting to ship from location other than the enlisting MEPS, immediately notify the enlisting SGC of the courtesy shipper request.

- (b) Validate that the FS's ERM record contains all required documents for shipping.
- (c) Contact the gaining station and inform the unit of the courtesy shipper.
- (d) Validate that the gaining station has contact with the courtesy shipper in their area.
- (2) Enlisting SGC, or designated representative, will:
 - (a) Notify the enlisting MEPS of the courtesy shipper and the gaining MEPS. Provide MEPS a Request for Orders (RFO) for the initial travel order or an amendment for an existing travel order IAW MEPS SOP.
 - (b) Send a paper copy of the courtesy shipper's enlistment packet to the gaining MEPS. The enlisting GC shop maintains the enlistment packet IAW respective GC shop's SOP.
 - (c) Ensure the enlistment packet and travel order arrive at the shipping MEPS NLT five (5) processing days prior to the projected ship day to allow MEPS transportation scheduling. Account for holiday schedules or closure for mandatory training.
 - (d) Project courtesy shipper in MIRS for the shipping MEPS immediately upon confirmation of arrival of the enlistment packet at the shipping MEPS.
 - (e) Validate the transfer of the enlistment record in MIRS.
- (3) The enlisting MEPS will:
 - (a) Create orders based on the RFO, and provides them to the SGC in sufficient time for the enlistment packet to arrive at the shipping MEPS.
 - (b) Amend the initial travel order based on the amendment RFO and send the amended order to the shipping MEPS if original travel order requires an amendment.
 - (c) Rescind the original travel order and provide the shipping MEPS with a copy of the rescinded order; the shipping MEPS can only amend an order once.
 - (4) The shipping MEPS will:
 - (a) Upon receipt of the enlistment packet take permanent ownership of the recruit file in MIRS.
 - (b) Make travel arrangements and prepare meal checks based on travel times.
 - (c) Charge travel arrangements to the shipping MEPS travel account.
 - (d) Create a new travel order for the individual if the enlisting MEPS rescinded the amended the order.
 - (e) Coordinate with the enlisting SGC for alternate ship day if the shipping MEPS are unable to obtain a reservation and ticket for the projected ship date.
- b. Prior to the FS's ship day, the shipping Bn Ops will:
 - (1) Validate the transfer of the FS's record in GCRc.
 - (2) Validate the shipping unit RSID is reflected in the GCRc record.
- c. Upon the FS accessing, or if a problem arises, notify the enlisting GC shop immediately.
- d. Overseas Courtesy Shippers: refer to appendix L and refer to the specific region for actions.

P-5. Hometown Shipping Program. (RA /AR)

- a. RA (only designated locations with HTS for RA): A GC is assigned for the participating companies with the responsibility to:
 - (1) Sign all DEP-out annexes with FS.
 - (2) Prior to FS departing, QC the enlistment record to ensure all documents have been properly completed and uploaded in ERM.
 - (3) Brief the FS on travel requirements, provide a safety briefing, and verify transportation.
 - (4) The Company Cdr/ISG is responsible for the following actions:
 - (5) Administer the Oath of Enlistment (commissioned officer only)
 - (6) Contact Bn Ops on ship day to validate shippers and report any no-shows
 - (7) Confirm FSs shipped and provide status to Bn Ops
 - (8) Validate all underweight/overweight FSs meet procurement standards
- b. AR: Hometown Shipping (HTS) is the only method of shipping AR Soldiers to training. The SGC or designated representative is responsible for the following actions:
 - (1) Project HTS IAW local MEPS' policies or SOPs.
 - (2) Ensure that HTS have "Hometown Shipper" and "Mode of Transportation" in the comments section of the UMF 727 and they are scheduled as shippers.
 - (3) Provide all required information to the MEPS for completion of orders, no later than seven (7) working days, prior to date of shipping. (Ensure orders reflect current residence.)
 - (4) Ensure that FS has at least 15 days in DEP/DTP.
 - (5) Complete MEPS ship packet breakdown IAW USMEPCOM Reg 601-23 and local MEPS policy or SOPs.
 - (6) Forward the FS's MEPS ship packet and meal checks to the responsible station no earlier than 15 days after enlistment or no less than 5 working days prior to FS ship day (the exception to this are the FSs who are quick

shipping). Ensure the physical is the most up to date one before forwarding the MEPS ship packet. Packet will not be released without verification that MEPS fingerprints have returned and the required background investigation has been submitted and has been accepted.

(7) Ensure FS's orders are uploaded in ERM.

(8) FSs requiring a Return Believed Justified (RBJ) must return to MEPS to clear their profile prior to HTS.

c. The station commander, or designated representative, is responsible for the following actions:

(1) Complete and upload the HTS checklist (UF 601-210.20) in ERM NLT three (3) days prior to shipping.

(2) Annotate any new conduct issues IAW appendix G.

(3) Ensure the FS has been screened for ht/wt requirements. Annotate all HTS ht/wt regardless of DEP-in weight standards, on the UF 601-210.20 and annotated in contact history within 72 hrs. of shipping. Upload a DA 5500/5501 in ERM, if applicable.

(4) Prepare a reno request IAW appendix H if the FS is temporarily disqualified.

(5) If it is determined that the FS is eligible for promotion IAW AR 601-210, 2-18, prepare the UF 601-210.23 and provide the TPU Cdr with the appropriate supporting documentation for completion of DA 4187 to promote the Soldier to the appropriate rank and pay grade. If the FS's ship date is within 15 days or the TPU commander is not available, the GC is authorized to process the DA 4187. GCs place the following statement in the remarks section for promotion, "AR TPU Cdr was not available for promotion of Soldier."

(6) Ensure each shipper has a government-issued photo ID for ship day. Government issued IDs are required by the airlines for boarding passes. The photo ID must have the same name as the airline ticket (check itinerary).

(7) Ensure that the shippers have meal tickets, travel cards, itineraries prior to travel.

(8) Verify the FS's OPAT PDC, OPAT consent form, and scorecard are within 90 days of ship date and that the FS achieved the qualifying PDC for their MOS.

(9) Ensure orders are in the FS's MEPS ship packet as well as uploaded in ERM.

(10) Provide transportation for the shipper from their home location to point of embarkation to training.

(11) Ensure to annotate shipping in the shipper's contact history.

(12) Confirm Soldiers have shipped and provide status to Cdr/ISG.

d. The Cdr/ISG is responsible for the following actions: Contact Bn Ops on ship day to validate all shippers and report shippers and no-shows IAW local SOP.

e. The Bn Ops is responsible for the following actions:

(1) Confirm the daily HTS status in REQUEST.

(2) Report any Soldier(s) as AWOL that are confirmed as "Ship" in REQUEST but do not arrive at the RECBN.

f. The following are guidelines for local MEPS functions:

(1) Process shipping projections IAW MEPCOM regulations.

(2) Notify liaisons of problem(s) associated with HTS.

(3) If there are holdovers, the Travel Assistant must rebook the flight and provide the itinerary to the GCs and if needed, amendment to the orders.

g. Special Instructions:

(1) Females will ship without a pregnancy test.

(2) Do not project HTS for lodging on the night prior to shipping. The only exception is for cases where the shipper lives a sufficient distance from the airport that requires an overnight stay. The shipper must lodge in the closest contract hotel to the point of embarkation. This requires Bn Ops approval 96 hours prior to projection.

(3) If the FS has a name change while in the DEP/DTP, ensure the respective MEPS are notified and the TPU has conducted name change IAW AR 600-8-104 (Military Personnel Information Management/ Records). Ensure FS has an updated Government issued picture ID with current name. Verify travel itinerary for the correct name.

(4) If HTS needs to ship from a different originating airport, Recruiters must contact MEPs immediately to process a request for orders (RFO) departing from the airport the HTS will be departing from. See MEPCOM Regulation 55-2 chapter 6.

h. Pacific Rim Shippers:

(1) Shippers (RA and AR) from Pacific Rim locations that normally do not ship from a MEPS location, are no longer required to have a medical inspect, prior to shipping provided there are no changes to the FS's medical condition. FSs ship as scheduled after processing thru the ship counselor provided they are otherwise qualified.

(2) Complete the UF 601-210.20.

P-6. Ship Date for BCT (RA and AR)

a. DEP/DTP/DS who require BCT will ship on a Monday or a Tuesday.

(1) If a Monday is a scheduled holiday, shippers will ship the following Tuesday and Wednesday.

(2) This applies to PS, GNPS and all NPS shipping to BCT.

b. GCs are required to ensure the ship date is scheduled in MIRS and transportation is scheduled IAW current MEPCOM policies.

c. Shippers' moves outside of the Monday/Tuesday window must be coordinated thru Bn Ops via the ROC only. Do not move shippers without authorization from the ROC.

Table P-2. USAREC Liaisons

LIAISONS	CONTACT INFORMATION
Fort Benning	30th AG BN (Reception) 5305 3rd Infantry Division Rd Bldg 3010, Ste 2E14 Fort Benning, GA 31905-5770 DSN: 784-9214 COM: 706-687-6929/7426
Fort Jackson	120th AG BN (Reception) Washington Rd Bldg 1895 Fort Jackson, SC 29207-6700 DSN: 734-4222 COM: 803-751-4222/5416/6308
Fort Leonardwood	43rd AG BN (Reception) 4566 Oklahoma Ave Bldg 2100, Room 138 Fort Leonardwood, MO 65473-5000 DSN: 581-0657/3613 COM: 573-596-0657/3613
Fort Sill	95th AG BN (Reception) 6005 Bessinger St Bldg 6005, Room 1012 Fort Sill, OK 73503 DSN: 639-2610/5008 COM: 580-442-2610/5008

Table P-2. USAREC Liaisons

Appendix Q

Required USMEPCOM Daily Reports and GCRc End of Day Report Records

Q-1. Purpose

This appendix outlines the daily reports pulled from MIRS, REQUEST, and GCRc.

Q-2. General

The GCRc system generates an email to the GC shop and Bn Ops informing that the results are not returned on the following schedule: 3 days for HIV results, 7 days for DAT results, or 21 days for ENTNAC results.

Q-3. Required USMEPCOM and Other Reports (GC shop)

The reports that are required to be generated and reviewed daily during GC shop opening are:

- a. MIRS Report 18 - Daily HIV Report (USMEPCOM PCN ZHM005)
- b. MIRS Report 9 - Daily DAT Report (USMEPCOM PCN ZHM002)
- c. MIRS Report 23 - Daily ENTNAC Submission Report (USMEPCOM PCN BIR)
- d. Daily UMF 727-E – MEPS Processing List.
- e. The SGC is responsible for the completion and accuracy of all Shipper Reports.
- f. The SGC validates the REQUEST Flagged Reservation Report to check for any flagged shipper REQUEST

records. The GC shop makes any necessary corrections to the flagged records.

NOTE: A copy of these reports will be attached to the UMF 727-E and maintained either in an electronic shared/common file or in the recruiting files in the GC shop (current year, plus previous 2 years). All MEPCOM reports will be maintained with the processing list for each day in the active files for each recruiting year.

Q-4. Required REQUEST and Close-out Reports (Bde and Bn Ops)

- a. Shipper Reports. The Bn Ops will provide a projected ship report monthly and weekly by component to MEPS. These reports are provided to the MEPS Travel Section IAW MEPS policy and/or MEPS SOP.
- b. Daily processing and shipping close-out. All Bdes are required to close out the end of day telephonically with USAREC through EEPD, ROC. If the SGC/GC ship confirms a scheduled shipper who failed to ship, the Bn S3 must immediately report the error by e-mail to USAREC: usarmy.knox.usarec.mbx.hq-g3-cepd@mail.mil.

Q-5. Procedures for Completing GCRc End-Of-Day Reports

SGCs will ensure accurate and complete dispositions are entered on all processors. The following result codes (RSLT CODE) will be entered by the GC shop:

- a. REQ TEST (Requires additional test) (A)
- b. TEST REJ (Failed ASVAB) (B)
- c. NOT QUAL (Does not qualify for enlistment) (C)
- d. REFUSED (refused to enlist) (D)
- e. ENLISTED (E)
- f. NO HELP (Applicant qualifies for enlistment, no jobs available) (F)
- g. NO CHG (No change from the last status) (G)
- h. CONFER (Applicant needs to confer with influencers) (H)
- i. OPT NOT POSS (Applicant desired job or option combination not possible) (I)
- j. DTP LOSS (AR cancellation) (J)
- k. DEP LOSS (RA cancellation) (K)
- l. LAW (Applicant revealed law violations, DD 369 required) (L)
- m. SHOP (Applicant shopping) (M)
- n. PMR (Permanent medical disqualification) (P)
- o. QUALIFIED (Qualified not scheduled to enlist) (Q)
- p. Reno (Reno completed) (R).
- q. TMR (Temporary medical disqualified) (T).
- r. ADMIN (Could not enlist for an administrative reason) (V)
- s. CCESED/SHIP VERIFIED (V)
- t. WINDOW (Wants to leave outside of available constraints) (W)
- u. ELOPE (Left MEPS prior to finishing processing) (X)
- v. FROZEN (Desired MOS currently on the frozen list) (Y).
- w. NO OPT (Qualified for enlistment, no jobs available) (Z)

Appendix R

Government Meals and Lodging Procedures

R-1. Purpose

This appendix outlines the process to ensure proper documentation for submission of Government Meals and Lodging and required actions by GCs.

R-2. General

SGCs are responsible for the overall proper documentation for Government Meals and Lodging. Documentation will be retained by electronic or by printed copies for 6 (six) years and three (3) months per Department of the Army

R-3. Primary Purpose for Submissions

- a. The GC is responsible for inputting the daily projections from GCRc to MIRS.
- b. MIRS generates automated versions of the UMF 727-E, Copy 2 but the status of each individual (applicant or enlisted) and the type room needed should be marked “double” and must be manually annotated. (The contract hotel will use this information in the billing process.)
- c. The UMF 727s will be checked to ensure that the appropriate three (3) position DoD Service/component code (Active Army/DAR; Army Reserve/DAV; AMEDD and Chaplain/DAZ) appears in block 3.
- d. The GC provides the UMF 727-E, Copy 2 (may be more than one) to the MEPS control desk, who will send the form to the contract hotel daily according to the local scheduled (generally by 1500).
- e. The contract hotel receives the UMF 727-E, Copy 2(s) for all Services and assigns rooms as the personnel arrive. Arriving personnel are required to sign in on the UMF 727-E, Copy 2 on the line bearing their name.
- f. In the event that a person is going to arrive at the hotel who is not projected on the UMF 727-E, Copy 2s, coordination is made between either the GC or the hotel to authorize a “Walk-in”. Walk-ins are listed on a UMF 728 and sign their names on the line bearing their name.
- g. The next morning, the hotel provides a summary daily invoice (UMF 729) and the signed UMFs 727/728 back to the MEPS control desk. The control desk should then make copies and provide them to the GC according to local SOPs.
- h. The GCs will review and reconcile all the UMFs. (This will be completed daily and copies retained.)
- i. If there is a problem noted on any of the documents the GC will coordinate with the MEPS QAE (generally the senior MEPS NCO) for resolution of the issue. The MEPS QAE should work with should work with the hotel to resolve the issue.

R-4. Daily Noon Meal Procedures

Noon meal procedures can have local variations, but will generally resemble this process.

- a. GCs will fill out the Daily Noon Meal Worksheet each morning by 0730 to order noon meals that are required for the day and provide the worksheet to the MEPS control desk.
NOTE: Meals ordered must be paid for whether or not they have been eaten.
- b. The MEPS control desk will order the meals from the vendor by 0800 daily as per contract requirements.
- c. The MEPS control desk will ensure the vendor receives a copy of the worksheet showing breakout of meals ordered by the Services and category (Applicant (Pre)/Enlisted (Post)).
- d. The GCs will track and retain the daily worksheets and sign in sheets to ensure validity of the monthly invoice from the vendor.
- e. If there is a problem noted on any of the documents the GC will coordinate with the MEPS QAE.

R-5. Month Procedures

- a. The contractors for both the Noon Meals and Meals and Lodging contracts prepare the monthly invoices within three (3) days of the end of the month and will send them to the MEPS QAE.
- b. The MEPS QAE will ensure that the invoices are detailed and provides a copy of each to the GC.
- c. The GC will reconcile the monthly invoices and inform the MEPS QAE if there is a problem.
- d. The GC will sign the invoices and contact the GPC cardholder for the Applicant Meals and Lodging Program. This contact will be made via emailing the signed monthly invoice to the GPC cardholder NLT the 10th of the month following the month the service is received.
- e. The GC will file the invoice and supporting documents (UMF 727, 728, and 729) together and retain them for a period of six (6) years and three (3) months. (Retention period is IAW DA GPC Operating Procedures, chapter 3-12.)
- f. GPC cardholders will contact the contractor authorizing them to charge the appropriate account for payment.

R-6. Forms

- a. UMF 727-E, Copy 1. GCs will complete this form when scheduling individuals for MEPS processing. Automated versions are printed from MIRS.
- b. UMF 727-E, Copy 2. GCs are responsible for initiating. When completing the preparation of UMF 727-E, Copy 1, and simultaneous entries on UMF 727-E, Copy 2 are made. Printed from MIRS.
- c. UMF 727-E, Copy 5. This voucher remains in use at the MEPS to control the applicants’ access to noon meals. It is not involved with the documentation of noon meal charges by the lunch vendor. The lunch vendor is paid for all lunches ordered whether eaten or not eaten.

d. UMF 728-E. This form is provided to the contractors and is used to document late arrivals, add-ons, or walk-ins. One form is used for all Services.

e. UMF 729-E. This form is provided to the contractors and is used by the contractors to record each day's meals and lodging charges for the services rendered. This form should be reconciled by the contractor, the MEPS, and the GCs.

R-7. Important Definitions

a. Applicant (App) – an individual who is processing for enlistment. Also referred to as “non-shipper” and/or “Pre” in this process.

b. Enlisted (Enl) – an individual who has completed all processing and is shipping. Also referred to as “shipper” and/or “Post” in this process.

R-8. Useful Reference

USMEPCOM Regulation 715-4, Applicant Meals and Lodging Program, dated 29 November 2010 and Department of the Army Government Purchase Card Operating Procedures dated 14 January 2013.

Appendix S

Electronic Records Management

S-1. Purpose

Guidelines for storing enlistment documents in ERM.

S-2. General

ERM is a standard yet simple advanced records management solution that is designed to meet the command's record information needs. Once a document has been uploaded in ERM it cannot be altered or deleted by anyone at any level in the command. The entire Soldier's record will be electronically maintained in Interactive Personnel Electronic Records Management System (iPERMS) from the time of accession until 62 years after the Soldier's service ends. Therefore, uploading documents in ERM must be done IAW with current policy.

S-3. Scanning/Uploading Enlistment Documents

a. All documents that are uploaded in ERM must be scanned as a standard PDF document. Documents that are uploaded with digital signature protection or password protection are being rejected by iPERMS and will not be viewable to the Soldier for future use. When a form needs to be uploaded that is digitally signed or password protected, the recruiter must print the document and rescan it prior to upload in ERM.

b. Documents that are system-generated such as the DD 1966 series and the automated annex(es) will be created in ERM by GCRc and will not need to be uploaded (electronically loads automatically). All additional documents and forms associated with the enlistment to include pre-screening/medical documents that must be presented to the MEPS prior to an applicant being floored and all documents received by MEPS personnel will be uploaded in the applicant's record, by the recruiter and/or GC on or prior to the applicant being projected. All documents and forms associated with shipping will be uploaded on or prior to the ship date. Extreme care must be taken to ensure all documents are legible and uploaded in the correct folder(s).

S-4. Process

Everyone in the enlistment process is responsible to ensure that all required documents are uploaded and unnecessary documents are not.

a. Documents generated at initial enlistment must be uploaded at that time. Some documents are electronically transferred and others must be manually uploaded.

b. Documents generated at shipping/accessing will be uploaded prior to confirming shipping in REQUEST. No FS will be ship confirmed without the required documents uploaded into the correct folder(s).

c. Only documents that are associated with the drop-down menu are authorized to be uploaded. "Do Not" upload blank documents or documents that are not required for enlistment/shipping.

d. NOTE: Some UM Acknowledgments are required to be uploaded as part of the enlistment record. The acknowledgments will be uploaded in the DEP folder as "Other".

e. Documents must be uploaded in the correct folder IAW associated drop-down menu. At NO TIME should any documents be uploaded in ERM that are not associated with the folder drop-down menu. For example: Hot Seat Checklist, blank documents, BDE/BN/Co/station questionnaires, 16 questions, etc., they are not authorized ERM documents. It is imperative that uploading is completed professionally and IAW current guidance.

Appendix T

U.S. Army Recruiting Command Liaisons at U.S. Army Reception Battalions (RECBN)

T-1. Purpose

This appendix establishes policies and procedures for USAREC liaisons assigned to U.S. Army RECBNs, the National Archives Records Administration (NARA), St. Louis (as advisors), the Defense Language Institute English Language Center (DLIELC), Lackland Air Force Base, TX, and Ft. Rucker, AL at the U.S. Army Aeromedical Center (flight physicals).

T-2. General

USAREC liaisons are assigned to G3, EEPD with duty at their respective installations. Due to the nature of their duties, liaisons will not be assigned additional duties or placed on duty rosters (for example; staff duty NCO, charge of quarters, etc.) by the RECBN commander or staff.

T-3. Responsibilities

a. The primary responsibility of the liaison is to reduce Soldier attrition at the RECBN. Liaisons are USAREC's quality control representatives in detecting and resolving unfulfilled, erroneous, or fraudulent enlistments. Liaisons are expected to resolve problems by reselling enlistment options, renegotiating option(s) (if not qualified for current options), and resolving improper or incomplete documentation problems by contacting the appropriate Bn, and by requesting ETPs to retain a Soldier who may not be qualified. The ETPs are sent to EEPD for reply or to forward to other agencies.

b. The secondary responsibility of the liaison is to assist and advise the installation commander and his or her staff, training Bde and Bn Cdrs and their staffs, and the RECBN Cdr on matters pertaining to the enlistment process.

T-4. Duties of the USAREC Liaisons

Since the operation of each liaison office will vary with the mission of the installation, each liaison will be required to modify operational procedures to support the local mission. Liaisons will;

a. Act as advisors to the RECBN on recruiting policies and procedures.

b. Perform liaison and coordinate problems between the RECBN, MEPS, BN Cdrs and subordinate elements as required.

c. Maintain close contact with the Post Adjutant General, IG, SJA, and RSD concerning recruiting matters.

d. Resolve defective, unfulfilled, or erroneous enlistments pertaining to new Soldiers caused by recruiting personnel and/or enlistment processing errors. Report all administrative errors and waivers required to complete enlistment, discharge, or separation using UF 600-8.3 to EEPD at usarmy.knox.usarec.list.g3-rcro-pp@mail.mil; RSD at usarmy.knox.usarec.list.hq-rsd-improprieties-mgmt@mail.mil; and the appropriate Bde/Bn S3 via email within three (3) working days.

e. Maintain UF 600-8.1 (RA and AR Inquiries to the Liaison) for all Soldiers who visit.

f. Maintain records, references and historical files on reportable errors IAW AR 25-400-2, record number 601-210h. Include at a minimum, before and after copies of effected documents, waiver statements, and REQUEST printout.

g. Record, log and process all alleged RMs identified at the RECBN.

h. Conduct interviews with Soldiers concerning alleged RMs, enlistment option(s) or MOS eligibility, recruiter or GC errors, irregularities, and fraudulent enlistments when requested to determine the validity of each case.

T-5. Flight Physicals (FOLLOW THE UM IRT FLIGHT PHYSICALS)

Once the flight physical is complete, the Bn Ops will:

a. Verify that all required flight physical test information and data entered on the DD 2807-1 and 2808 is correct. If the physical is missing test information or data, return it to the recruiter or administering facility for completion with the FS, if required.

b. Establish a log that contains the FS's name, SSN, physical location, recruiter's name, RSID, date the physical was received at the BN and mailed to Ft. Rucker, a block for the return date, approval or disapproval date, and a remarks block.

c. Attach to the flight physical the completed UF 600-8.4 (Flight Physical Cover Sheet) with the appropriate return address and POC inside the block at the bottom of the sheet. Mail the physical and UF 600-8.4 to: US Army Aeromedical Center, ATTN: MCRY-AER-AAMA, 5700 Novosel Street, Ft. Rucker, AL 36362-5333.

d. Upon approval, complete the log with an approval date and ensure the control number that was issued by the liaison is in the remarks section of the DD 1966. The approved physical will remain with the liaison at Ft. Rucker.

The control number is the verification of an approved physical.

e. When a suitable facility for administering flight physicals resides outside a reasonable driving distance of the FS, recruiters will contact their Bn to have the appointment and transportation scheduled. Bns will issue travel orders to the closest supporting facility that administers flight physicals.

T-6. Record Requests

Liaison will:

a. Request records not available within Army systems such as iPerms, Integrated Web Services/Soldier Management System (IWS/SMS), Personnel Network (PERNET), Automated Orders and Resource systems (AORS), Defense Manpower Data Center (DMDC), Reenlistment Eligibility Data Display (REDD), Defense Personnel Records Information Retrieval System (DPRIS), GCRc, from the appropriate Service component and other systems.

b. Provide guidance and resolve issues concerning current and PS records, status, and Service. Issues may include, but are not limited to conflicting, erroneous, or missing data in a Soldier's record or database.

c. Provide authorized agencies/petitioners documentation to resolve issues for records requiring contact or correction.

d. Provide guidance for submission of correction to agencies that require direct request from a Soldier.

e. Validate request forms (UF 600-8.6, SF 180, and SF 86 when required) to ensure correctness. Contact sender if he/she did not fill out the request form correctly, or for clarification.

f. Process all requests, researching systems and request files from appropriate agencies.

g. Review and validate records and systems for corrections to include DD 214 and complete DD 215.

h. Forward requests for corrections and supporting documentation to the appropriate agency by Service component.

i. Develop MFRs to address missing documentation needed for processing of PS personnel who do not require record corrections.

j. Process records, certify and send via email or FEDEX to appropriate personnel.

T-7. U.S. Army Foreign Language Recruiting Initiative (FLRI) and English Language Training (ESL) Liaisons

The primary responsibilities of these liaisons is to coordinate the administration of the Armed Forces Classification Test (AFCT) for Soldier who enlist for FLRI through the test administrator at Echo Company (E Co) DLIELC, Lackland AFB, TX. Additional responsibilities are:

a. Report erroneous and fraudulent enlistments.

b. Identify and report trends found in enlistment processing procedures to the EEPD, PS Accessions/Liaisons.

c. Provide briefing(s) to the DLIELC commander.

d. Serve as a link between USAREC and TRADOC on recruiting related matters pertaining to ESL and 09C enlistment programs.

e. Provide Basic Skills Education Program (BSEP) instruction to Soldiers enlisting as a 09C after the completion of English Language Training (ESL).

T-8. Physical Security

a. The liaison is responsible for the physical security of his/her Command Operations Center (CoC). Instance of damage or theft of property under USAREC control will be reported immediately via email to:

usarmy.knox.usarec.mbxg3-coc-officer@mail.mil

b. Acts of vandalism, demonstrations, threatening behaviors, bomb threats or force protection incidents must be reporting reported using UF 190-4.2; Serious Incident Report.

(1) The CoC-Security Watch Officer can be reached at (501) 626-0823/0824. The watch officer desk hours are 24/7.

(2) Each liaison office will have on file an authorization memo specifically designating access to REQUEST terminals IAW AR 25-2. The individual liaison will maintain REQUEST computer terminals, software, and computer access codes.

T-9. Personnel and Administrative Functions

Each liaison is responsible for the resolution of Soldier's issues involving promotions, marital status, dependents, etc.

a. USAREC retains administrative and UCMJ jurisdiction for liaisons unless transferred IAW AR 27-10 chapter 5-2b.

b. Each liaison will adhere to USAREC's SOP for liaisons and update as the installation's mission demands, but at least yearly. The SOP must address normal processing procedures, ways to solve typical MOS related problems and contact information for those who can help solve problems. The liaison will send a copy of their SOP to the EEPD, PS Accessions/ Liaisons.

T-10. Logistical and Communication Support.

a. Logistical and communication support to the liaison offices are provided by the Bns that have liaison locations inside their area of operations;

- (1) Atlanta Bn – Fort Benning, GA.
- (2) Oklahoma City Bn – Fort Sill, OK.
- (3) Columbia Bn – Fort Jackson, SC.
- (4) Montgomery Bn – Fort Rucker, AL.
- (5) San Antonio Bn – Lackland Air Force Base, TX.
- (6) Kansas City Bn – Fort Leonard Wood, MO.

b. The liaison will comply with the policies and procedures of the supporting Bn as to logistics and communications. Problems that cannot be resolved will be referred to EEPD, PS Accessions/Liaisons at (502) 626-0362.

Appendix U Occupational Physical Assessment Test (OPAT)

U-1. General

The Occupational Physical Assessment Test (OPAT) is a battery of four physical fitness test events that will be used to assess an individual's physical capabilities to engage physically demanding Army tasks. The four test events consist of the standing long jump, seated power throw, strength deadlift, and the interval aerobic run. The standing long jump, seated power throw and strength deadlift can be performed in any order; however, the interval aerobic run must be performed as the last event.

U-2. Policy

a. All RA and AR shippers require the successful completion of the OPAT after enlistment into the (FSTP DTP/DS) as specified by the Physical Demands Categories (PDC). Every MOS has a PDC. All FSs must have a passing OPAT PDC for their selected MOS within 90 days of shipping to training.

b. PDCs (Binning Spreadsheets) are categorized as:

- (1) Heavy 'H'
- (2) Significant 'S'
- (3) Moderate 'M'
- (4) Unprepared 'U'*

(5) Achieving PDC 'H' qualifies a FS for all MOSs under that category and in addition all MOSs under category 'S' and 'M'. Achieving category 'S' qualifies a FS for all MOSs under that category and category 'M'. Achieving category 'M' only qualifies a FS for MOSs under that category.

NOTE: There are no MOSs that fall under category 'U'.

c. OPAT will NOT be administered without the FS signing the OPAT consent form. The consent form uploaded in RZ under the 'Core Admin Folder' (bearing the title of the form). OPAT scorecard will be uploaded in the RZ OPAT page after the FS's signature and certification of the scores. Reservation cancellation and discharge procedures will be initiated for FSs refusing to consent to take the OPAT or refusing to sign the OPAT scorecard.

d. FSs are not authorize to ship without a signed consent form and a signed scorecard by the FS and the administrator. Results must be updated in RZ and REQUEST.

(1) The FS will print full name (First, Middle, Last), sign and date the scorecard in the "Qualification Level/ Comments" block after the test has been given to certify that he/she had in fact taken the test (must achieve the minimum acceptable score, for the selected MOS, in each event in that single session) and acknowledges his/her test scores.

(2) The test administrator or station commander will upload the signed scorecard in the FS's record after his/her signature and verify the scores in RZ as soon as possible.

NOTE: GC are reminded to review the flagged record report daily for the FSs who have not met the PDC requirement for the MOS selected.

(3) GCs will validate that the FS and the OPAT testing administrator have signed the OPAT scorecard within 90 days of shipping to training. All discrepancies will be reported to the responsible Company Cdr/ISG

immediately.

e. The station commander or test administrator will enter the raw OPAT scores in RZ.

(1) Select the "Future Soldier's Questionnaires" page under "I Want To...", "Maintain Occupational Physical Assessment Tests."

(2) Select 'Add' in the "Enter and Update OPAT Scores" page. Beginning with the test date, complete each section to record the results of the FS's OPAT.

(a) Test date

(b) Standing Long Jump (must enter 4 digits; start with 0).

(c) Seated Power Throw (must enter 4 digits; start with 0).

(d) Strength Deadlift (click the drop-down arrow and select the highest weight successfully lifted correctly).

(e) Interval Aerobic Run (list the last successful Level#, Shuttle#, and Total# of shuttles in the appropriate boxes).

(f) All steps must be completed to update or add an OPAT score.

(3) OPAT scores must reflect a FS maximum effort in each OPAT fitness test event. All four OPAT events must be administered within a one-hour session. The FS must achieve the minimum acceptable score, for the selected MOS, in each event in that single session.

(4) Once all the scores have been entered, select the "save" button. The new scores will be added to the summary box along with the summary of the previous scores. After the OPAT has been saved, select the score and verify option to populate REQUEST. Immediate retests are authorized without an ETP. FSs may complete multiple OPATs. Regardless of the multiple tests, the only qualifying score is the test taken within 90 days of shipping. Systems have not been updated to flag a FS record if he/she fails to score the PDC (within 90 days of shipping) required for the MOS after passing the PDC score earlier. GCs will validate within 90 days of shipping to training, the FS and OPAT test administrator has signed the OPAT scorecard and the FS had passed the PDC required for the MOS selected.

NOTE: Recruiters will establish a Physical Readiness Training Path IAW UR 601-210, appendix O-5 to assist and prepare FSs with OPAT testing.

U-3. Future Soldier Tracking Log

OPAT scores populate to the Future Soldier Tracking Log in RMZ. The report will display any OPAT data to support the 90-day requirement. Additional columns are as follows;

a. OPAT Pre-Ship Date; displays any OPAT score within 90 days of shipping.

b. OPAT Pre-Ship Rating; displays the OPAT rating (PDC) for a score from the "OPAT Pre-Ship

c. OPAT Pre-Ship Qualified; displays a 'Y' or 'N' based on the "OPAT Pre-Ship Rating" and the OPAT (PDC) required for the MOS.

NOTE: The "OPAT Pre-Ship Qualified" column must reflect a 'Y' for the FS to ship.

U-4. OPAT Renegotiations

Renegotiation for OPAT must be completed as soon as possible. FSs who do not meet the PDC requirement can be given as many opportunities to pass while in the FSTP. Use the following codes;

a. OF - Failed to achieve the minimum OPAT score (U-Unprepared).

b. OP - Exceeded current MOS OPAT Score; for example: FS MOS PDC requirement 'M'. However, score is category 'H'. FS could request to renegotiate in an MOS with an OPAT score category 'S' or 'H'.

c. OD - Failed to achieve minimum OPAT score for MOS; for example FS MOS PDC is 'H'. However, FS OP score is category 'S'. The FS must renegotiate in a MOS with an OPAT score category 'S' or 'M'.

U-5. OPAT Loss/Cancellation

Losses/Cancellations, use the following codes:

a. OF - Failed to achieve minimum OPAT score.

b. OD - Failed to achieve minimum OPAT score for MOS.

c. OR - FS refused to take OPAT.

U-6. OPAT Discharge Orders SPD

The Separation Program Designator (SPD) code of 'ZED – No Longer Qualified for Option and Declines Alternate' will be used on all discharge orders for FS who are taken as an OPAT loss (whether it was due to failure or refused to take the OPAT).

U-7. PS and GNPS

Army PS/GNPS OPAT validity period is 36 months past their Military Service Obligation (MSO).

a. RA PS/GNPS applicants who are enlisting in their original MOS and are not attending training are not required to be administered the OPAT, the scores must still be verified in RZ to prevent errors in ship confirming. In RZ under "Maintain Occupational Physical Assessment Tests", click "score and verify". Ensure there is a "Y" in "verified".

b. PS/GNPS who are not enlisting in their original MOS and are going to training are required to be administered the OPAT within 90 days of shipping. PS/GNPS must pass OPAT with a PDC of their selected MOS.

c. AR PS/GNPS applicants who enlist in a 'will-train' MOS that is not their original MOS with a different OPATPDC are required to take the OPAT at their respective unit. AR PS/GNPS who have to attend AIT must meet the OPAT PDC for the AIT they are scheduled for within 90 days of shipping.

d. AR PS/GNPS applicants who require BCT must take and pass the OPAT. PS/GNPS must have a passing OPATPDC for their selected MOS within 90 days of shipping, if attending training.

U-8. 6BDE DEP Trips and Remote Alaska (RA and AR)

a. Applicants processing from the Federated States of Micronesia (FSM), Palau or the Republic of Marshall Islands who enlist remotely as a result of a MEPS DEP trip will take the OPAT during the 3-5-day period that the FS is on Guam attending FS training and submitting a SSN card request.

e. Applicants processing at Anchorage MEPS who are flown in from remote locations will take the OPAT during after enlistment if they are NOT within a two (2) hours radius from a station. The FSs will be held over for the test. The test will be given by Anchorage North or Anchorage South stations.

U-9. FLRI and ESL

a. MOS 09C (FLRI Program) requires a minimum 'M' category. The USAREC liaison at Lackland AFB will renegotiate Soldier in an MOS upon successful completion of English as a Second Language (ESL) using the PDC attained while in the FSTP.

b. Passing OPAT scores are valid until the completion of ESL.

U-10. Options 4 and 40 and ACASP

a. OPAT PDC for Option 4 (Airborne) or 40 (Ranger) will be determined by the selected MOS. Example-11X Option 40 is an 'H', 92G Option 4 and 40 is a 'S'.

b. ACASP FSs are required to qualify in an OPAT PDC for the ACASP MOS they enlisted in whether or not they are required to attend AIT.

U-11. MAVNI

a. RA MAVNI 09U will test and must score in one of the three PDCs (H/S/M) after they have been cleared to training. This test can be administered after their MOS has been renegotiated and must be within 90 days of the new ship date.

b. AR MAVNI will test and must score in the PDC required for his/her MOS. Although the training seat has been cancelled the FS must still meet the required PDC to ensure successful pull of a training reservation. Once the reservation has been pulled the FS will need to retest within 90 days of shipping.

U-12. Officers and SMP

a. Officer MOSs; 09B/Q/R/S/W all require "M" category prior to shipping.

b. 09R (SMP) NPS/PS TPU Cdrs will ensure cadet takes OPAT prior to attending training when applicable.

U-13. Training and Other Resources

a. Comprehensive training can be located at;

<http://span.usarec.army.mil/sites/HQ/G3/Training/TSP/Documents/Forms/AllItems.aspx?RootFolder=%2Fsites%2FHQ%2FG3%2FTraining%2FTSP%2FDocuments%2FOPAT%20Training%20the%20Trainer%20Documents&FolderCTID=0x012000B0130D123E58AF4BB34265C254917286&View={50DB2925-A6FE-40FD-BD03-17BA10DE7543}>

b. OPAT information to include the PDC (Binning Spreadsheets), Scorecard, Consent Form, Testing Instruction and Video links are available in IKRome, EEPD on both the ROC and Policy pages;

<https://span.usarec.army.mil/sites/HQ/G3/EEPD/SitePages/Policy.aspx> or on IKRome homepage

(1) Select All SharePoint Sites

(2) Select G3 Plans and Operations

(3) Select the Enlistment Eligibility Processing Division under the Divisions

(4) On the EEPD homepage select the 'ROC' or 'Policy' tabs

NOTE: Ensure to continuously check the Binning spreadsheets as PDC requirements may change.

Appendix V. Temporary Reservation Procedures

V-1. Purpose.

This appendix establishes standardized procedures for the use of the temporary reservation (temp res) in RZ.

V-2. General

Temp res is a process that allows the recruiter and applicant to make an MOS selection and temporarily reserve the MOS.

V-3. Recruiter Procedures

a. Recruiters will review UR 601-210 Appendix B-4 prior to making a temp res.

b. Any applicant requiring a conduct waiver or suitability review IAW AR 601-210, chapter 4, must have the waiver or suitability review completed and approved before making a temp res.

c. The applicant must have a qualifying ASVAB score or line score predictor (PiCAT, EST or WinCast) results. If the PiCAT is used, the applicant must take and pass the PiCAT Verification Test (VTest) to remain qualified for the selected MOS on the temp res.

d. When the QT and line scores are obtained, the recruiter will build the applicant's record in RZ. If the applicant is not physically qualified by taking a MEPS examination, the system will populate the record with a PULHES (Physical capacity, Upper extremities, Lower extremities, Hearing, Eyes, and Psych) profile of 111111.

e. The record can be constructed before a recruiter has verified the applicant's data with source documents. HOWEVER, a reservation will not be "pulled" until all source documents are obtained, verified, and uploaded into the applicants record in ERM IAW AR 601- 210, chapter 2. The temporary reservation can be pulled without the applicant present. Pulling a reservation with known discrepancies, or missing source docs is prohibited.

NOTE: When the ROC is called for assistance in pulling a reservation, the ROC counselor may have some additional options and or bonus packages available that may need to be conveyed to the applicants. It is advisable that if the applicant is not present when the ROC is called, to at least have the applicant available either by a three way call, ZOOM, TEAMS, etc.

f. Recruiters are authorized to make only two temp reservations on a single applicant. If for any reason an applicant needs a third reservation it must be pulled as a permanent reservation by a GC. Renegotiation of a temp res is prohibited. (Reservations for uncommitted applicants tie up training seats and prevent qualified/committed applicants from securing one of these training seats.)

g. Recruiters must perform the following steps:

(1) Ensure the search starts on the first Monday 14 calendar days AFTER the enlist date (day the applicant will be at the MEPS to join) (both RA and AR).

(2) For high school seniors' searches will start the Monday 14 calendar days after the graduation date shown on the high school letter (both RA and AR) to ensure a minimum of seven (7) days in the DEP/DTP prior to departure for training after graduation.

h. On Reservation Summary:

(1) Select MEPS.

(2) Select Pay grade per AR 601-210, chapter 2-18.

(a) If pay grade not E01 select correct advance Rank Reason.

(b) Enter correct College Semester Hours or zero if none.

(c) Select all appropriate math and sciences (some MOSs require only completion, others require a passing grade, always validate). (Must have transcripts loaded in ERM to validate anything other than general math or science.)

(d) Select the correct color vision; Normal-normal, R/G-Red/Green, or No Color Vision-completely color blind.

i. On the Eligibility screen; training type for normal DEP and MOST DTP are Standard. Alternate is for AR Split Training.

j. On the Preferences screen; refer to appendix V-3a and V-3b.

k. Perform a job search or lookup in the same manner as a GC.

l. On the Opportunities screen;

(1) Select UNCM (uncommitted).

(2) Reserve MOS and print the reservation letter.

(3) Inform the applicant a temp res is contingent upon the applicant qualifying for enlistment. The applicant must meet mental, medical and conduct qualifications. (The MOS may have additional prerequisites and/or qualifications.)

(4) AR - Change the 'enlistment date' on the completion screen to the date the applicant will complete his/her processing and swear in at the MEPS.

m. Upload source documents in ERM. Including all pages of the temp res. PiCAT or EST score printout will be uploaded behind the temp res, if applicable.

n. Temp res are valid for seven (7) calendar days. Cancel the reservation if the applicant cannot complete enlistment processing within the seven (7) calendar days.

o. Recruiters are authorized to call the ROC directly during normal duty hours, Monday through Thursday 0700-2000 EST, Friday 0700-2100. All other business must be performed during normal duty hours using the queue line; 1-800-699-9203, ext. 2. Recruiters can call for assistance under the following circumstances;

(1) DEP/DTP control window exceptions. All grad applicants must ship to training within the "window of opportunity". If the applicant cannot ship within this window, the recruiter will assist the applicant in writing a statement and provide necessary supporting documents to further demonstrate as to why they want or need to ship after a specific date. This statement and supporting documents become source document, justifying the ETP (shipping outside the DEP/DTP control window).

(2) Line score ETPs. If there are no MOS opportunities showing for the applicant, a call can be made for assistance. Line score ETPs are not always favorable. Under no circumstances will a line score ETP be granted based on-line score predictor test; PiCAT, EST or WinCAST.

(3) Recruiters must do as much "homework" as possible before calling. This includes having an applicant's statement prepared and knowing what MOS and what week the applicant needs or desires. The ROC counselor will receive acknowledgment from the recruiter that the applicant's record has been validated for accuracy and completeness, and is fully qualified prior to requesting assistance in making a reservation.

V-4. GC Procedures

a. GCs will check records for completeness, level 3 and 4 validations, and ensure the applicant meets the MOS qualification. The GC will wait until the applicant is mentally and physically qualified and the dates and scores have been updated in MIRS and transferred to the GCRc 680 before submitting the applicant's record to REQUEST.

(1) Ensure all supporting documentation validating an applicant's qualification for an MOS are uploaded in ERM prior to converting or pulling a permanent reservation.

(2) Once the data is transferred to REQUEST, update the REQUEST record. Ensure AR "Enlist Date" is correct for AR applicants.

(3) GCs will be unable to convert reservations if the record does not pass level 3 and 4 validations.

b. Records that are constructed based on PiCAT, if the V-Test QT score lower below 50 and incentives are attached to the temp res the GC will not be able to convert the res to permanent. The existing temp res must be canceled and a new reservation made on the production scores. If there are no incentives attached, the record will convert.

c. In cases when the QT increases above a 50, the GC will delete the bravo incentives and update the record with alpha incentives, if applicable. Contact the ROC immediately with issues, do not cancel the temp res.

d. If the applicant is no longer qualified for the MOS the temp res will be cancelled. DO NOT renegotiate the temp res.

e. Always use "TR" temp res as the cancellation code. Ensure remarks are annotated with the reason for cancellation. DONOT renegotiate the temp res.

f. In the event the applicant is disqualified medically and the disqualifying factor cannot be overcome within the seven (7) day temp res period, the recruiter or GC will cancel the temp res.

g. The SGC and GCs remain the final authority for the verification of applicant qualifications, to include MOS qualifications, for enlistment in the RA or AR.

h. BN and BDE Ops will monitor the reservations being made within their AOs. Instances of multiple reservations and cancellations will be treated as abuse of the system.

V-5. APT and PiCAT Testing Procedures

a. APT testing procedures.

(1) The APT consist of 20 questions (4 Arithmetic Reasoning, 8 Word Comprehension, 3 Paragraph Comprehension, and 5 Mathematics Knowledge). The APT can be taken multiple times and does not affect the applicant's ability to take the PiCAT or ASVAB.

(2) The APT is a test that is similar to the CAT-ASVAB, but much shorter. It is used to predict performance on

the Armed Forces Qualification Test (AFQT). For best performance, the location should offer the opportunity for 20-30 minutes with no interruption. After review and explanation of the Privacy Act, recruiters will register applicants and provide them a unique access code. Site URL to register the applicant and be found at <https://www.dmdc.osd.mil/icat-ar/>.

(3) Access codes are valid for 30 days. Once the code is used, the applicant has 48 hours to complete the test.

(4) Applicants must go to <https://www.dmdc.osd.mil/icat/apt> in order to take the APT and must use the code provided by the recruiter.

(5) Recruiters can access their applicant's score in the "Authorization and Reporting" tab as soon as the applicant completes the APT.

(6) Recruiters can access the APT brochure by going to the EEPD home page and following the link to the "Battle Ready Resources" tab. This brochure can also be found by following the link below:

<https://span.usarec.army.mil/sites/HQ/G3/EEPD/BattleReadyResources/SitePages/Home.aspx>

b. PiCAT Testing Procedures.

(1) Applicants must be 17 years of age to be authorized to take the PiCAT.

(2) PiCAT can be taken if an applicant has taken a Student ASVAB (SASVAB), however cannot be taken if SASVAB test pull has occurred.

(3) PiCAT can be taken if an applicant has previously taken the ASVAB, only if two years has passed since last test was taken. This includes GNPS/PS.

(4) After review and explanation of the Privacy Act, recruiters will register applicants and provide them a unique access code. The applicant can be registered at <https://www.dmdc.osd.mil/icat-ar/>.

(5) Once an access code has been issued, the applicant will have 31 days from time of registration to access the PiCAT. PiCAT testing will only be available for 48 hours once the applicant initially begins the test. Applicant must access the PiCAT at <https://www.dmdc.osd.mil/icat/prescreen>.

(6) The applicant will need to achieve a minimum Armed Forces Qualification Test (AFQT) score on the first five sections of the test in order to complete the remaining sections. Applicants who do not meet the minimum AFQT score (AFQT 25) will not be permitted to proceed to a proctored verification test (Vtest) and a full ASVAB will be required to be taken for enlistment.

(7) Recruiters are able to access the applicant's PiCAT score results once the applicant has completed the test. Prescreen Score Report must be uploaded into ERM if the PiCAT is going to be used for enlistment.

(8) Applicant will have 30 calendar days once the PiCAT is completed to take a Vtest at the MEPS or a MET Site with iCAT capabilities. The PiCAT is time stamped and will expire to the minute it was finished; therefore it is not recommended to project for the Vtest on the 30th day as it may not be administered in time. It is advisable to ensure Vtest is completed within the first 21 days after initial PiCAT in order to avoid PiCAT expiration.

(9) Applicants are not authorized to take the PiCAT in school or on a school computer.

(10) The test date will be the date the PiCAT was initially taken, not the date the Vtest was taken.

c. Temporary Reservations.

(1) Once an applicant has completed the PiCAT and the Prescreen Score Report has been uploaded, the results of the report can be entered in the Test Score section of RMZ. It is imperative that line scores are entered exactly as listed on the report. Once scores have been entered they cannot be edited and will require deletion if an error occurs.

(2) For the APT: Select "Add EST" in the "Test Scores" section. Then under Test Date, enter the date listed on the score report.

(3) Select "manage a temporary reservation" and PiCAT scores that were entered should match what was entered from the Prescreen Score Report. All remaining steps remain the same when making a reservation.

d. Processing Procedures.

(1) Applicant completes PiCAT.

(2) Upload PiCAT Prescreen Score Report in ERM.

(3) Project applicant for ASVAB by selecting "Verification Test," from the dropdown on the projection screen in RZ. Verification test can be completed at either the MEPS or a MET Site.

(4) Upload a UMF 680-3A-E in ERM with "Verification" written across the top. A printed copy of the UMF 680-3A-E will need to be hand carried by the applicant if the verification test is being taken at a MET Site.

(5) The SGC/GC needs to project the record in MIRS to reflect "VTest" as the test to be taken in the comments. This will document the proper test on the USMEPCOM Form 727-E.

e. Verification Test.

(1) The Vtest is a 25-30 minute proctored test to validate that the applicant took the test properly. The Vtest validates the PiCAT score for use as the official test score of record and will detect any inconsistencies which will cause an unconfirmed test result.

(2) If the Vtest is validated, the applicant will enlist under their PiCAT score.

(3) If the Vtest is not validated, the applicant will be automatically routed to a full length ASVAB and the resulting score will be the score of record. The Vtest is considered an initial test, current retest rules will then apply.

(4) Applicants will be randomly chosen to take a full length ASVAB in addition to the Vtest in order to continually validate the testing algorithms. It is only for research purposes and is not to be used for enlistment. Report any test discrepancies immediately to respective Battalion PiCAT Project Officers (PO), in order to attempt a resolution with MEPCOM.

f. Initial Setup Procedures.

(1) All recruiters must be provisioned either as a SSM or a PiCAT recruiter in order to access the iCAT database to issue PiCAT codes to applicants and have the ability to query score reports. The SSMs are responsible for the adding, unlocking, and removing (PCS, ETS, Flag, etc.) of all PiCAT recruiters within their assigned station when necessary. Accounts will be locked after 45 days if not being used and then will require the SSM to unlock the account.

(2) A PiCAT Analyst role is available to BDE/BN staff members which allows the user to query PiCAT results for analysis purposes. See local SSM for access. Once provisioned, the user can access the following link at <https://www.dmdc.osd.mil/icat-ar/>.

(3) PiCAT procedures, roles and responsibilities, and training documents can be found at the following link <https://span.usarec.army.mil/sites/HQ/G3/SitePages/PiCAT-REDD%20Procedures.aspx>.

Glossary

Section I Abbreviations

AAR

After Action Review

ABS

Applicant Background Screening

ABSM

Applicant Background Screening Manager

AC

Active Component

ACASP

Army Civilian Acquired Skills Program

AD

Active Duty

AFQT

Armed Forces Qualification Test

AFR

Advance Fingerprint Report

AFS

Active Federal Service

AFSC

Armed Forces Specialty Code

AFVT

Armed Forces Vision Test

AIT

Advanced Individual Training

AMEDD

Army Medical Department

AO

Assembling Objects

AR

Army Reserve

ARISS

Army Recruiting Information Support System

ARN

Alien Registration Number

ARNG

Army National Guard

ASI

Additional Skill Identifier

ASVAB

Armed Services Vocational Aptitude Battery

ATP

Alternate Training Program

BCT

Basic Combat Training

BI

Background Investigation

BIR

Background Investigation Report

BJA

Brigade Judge Advocate

BCT

Basic Combat Training

CCF

Central Clearance Facility

CCT

Case Closing Transmittal

CEP

Career Exploration Plan

CG

Commanding General

CID

Criminal Investigation Division

CIHS

Currently In High School

CMF

Career Management Field

CMO

Chief Medical Officer

CSB

Customer Support Branch

CSM

Command Sergeant Major

DA

Department of the Army

DAT

Drug and Alcohol Test(ing)

DCG

Deputy, Commanding General

DEP

Delayed Entry Program

DLAB

Defense Language Aptitude Battery

DLIELC

Defense Language Institute English Language Center

DLIFLC

Defense Language Institute Foreign Language Center

DOD

Department of Defense

DOS

Days of Service

DS

Delayed Status

DTP

Delayed Training Program

EAD

Extended Active Duty

EB

Enlistment Bonus

EBC

Electronic Background Check

ECLT

English Comprehension Level Test

EER

Erroneous Enlistment Report

EEPD

Enlistment Eligibility Processing Division

EFMP

Exceptional Family Membership Program

EIS

Enlistment Inquiry Section

ELS

Entry Level Separation

ENSQ

Entrance Inquiry Section

ENTNAC

Entrance National Agency Check

EREC

Enlisted Records Evaluation Center

ERM

Electronic Records Management

ESL

English as a Second Language

ESS

Education Services Specialist

ETP

Exception to Policy

ETS

Expired Term of Service

FAZR

Force Structure and Zip Code Realignment System

FBI

Federal Bureau of Investigation

FIC

Family Information Center

FOUO

For Official Use Only

FS

Future Soldier

FSR2S

Future Soldier Remote Reservation System

FSTP

Future Soldier Training Program

FSTS

Future Soldier Training System

FY

Fiscal Year

GC

Guidance Counselor

GCOG

Guidance Counselor and Operations Course

GCRc

Guidance Counselor Resource Center

GED

General Education Development

HCR

Health Care Recruiter

HIV

Human Immunodeficiency Virus

HQDA

Headquarters, Department of the Army

HQ USAREC

Headquarters, US Army Recruiting Command

HRC

US Army Human Resources Command

HSD

High School Diploma

HSDC

High School Diploma Graduate via College Credit

HSDG

High School Diploma Graduate

HSS

Headquarters Support System

HTS

Hometown Shipping

IADT

Initial Active Duty Training

ID

Identification

IET

Initial Entry Training

IEP

Individualized Education Program

IG

Inspector General

IMO

Information Management Office

IMT

Initial Military Training

IO

Investigative Officer

iPERMS

Interactive Personnel Records Management System

IRR

Individual Ready Reserve

JPAS

Joint Personnel Adjudication System

LOA

Letter of Acceptance

LRP

Loan Repayment Program

LS

Live Scan

LZ

Leader Zone

MEPS

Military Entrance Processing Station

MET

Military Entrance Test

MFR

Memorandum for Record

MGIB

Montgomery GI Bill

MIRS

MEPCOM Integrated Resource System

MOS

Military Occupational Specialty

MOSC

Military Occupational Specialty Code

MRD

Mandatory Return Date

MRE

Meals, Ready to Eat

MSO

Military Service Obligation

MTF

Military Treatment Facility

NACLC

National Agency Check and Local Check

NCO

Noncommissioned Officer

NCOIC

Noncommissioned Officer in Charge

NGYCP

National Guard Youth Challenge Program

NPS

Non-Prior Service

OARS

OPI Authorization and Reporting System

OCS

Officer Candidate School

OIC

Officer in Charge

OIP

Organizational Inspection Program

OMPF

Official Military Personnel File

OPI

Oral Proficiency Interview

OPM

Office of Personnel Management

OPS

Operations

OSD

Office of the Secretary of Defense

OSUT

One-Station Unit Training

PAI

Pre-accession Interview

PAL

Police Agency Listing

PaYS

Partnership for Youth Success

PE

Physical Examination

PEI

Pre-enlistment Interview(er)

PL

Processing List

PMOS

Primary Military Occupational Specialty

PMR

Permanent Medical Rejection

PPR

Processing Procedure Review

PRID

Person Identification

PRP

Personnel Reliability Program

PRT

Physical Readiness Training

PS

Prior Service

PSSP

Personnel Security Screening Program

PT

Physical Training

QC

Quality Control

QNE

Qualified Not Enlisted

QRP

Quality Review Program

QUALS

Qualification Requirements

PEQ

Physical Examination Qualified

RA

Regular Army

RAP

Record of Arrest and Prosecution

RBJ

Reevaluation Believed Justified

RC

Reserve Component

RCST

Reading Comprehension Screening Test

RE

Reenlistment Eligibility

REQUEST

Recruit Quota System

RECBN

Reception Battalion

RECSTA

Reception Station

REFRAD

Released From Active Duty

RENO

Renegotiation

RI

Recruiting Irregularity

RLAS

Regional Level Application Software

RM

Recruiter Misconduct

RMZ

Report Management Zone

ROC

Recruiting Operations Center

ROI

Reports of Investigation

ROTC

Reserve Officers Training Corps

RPI

Recruiting Publicity Item

RSID

Recruiting Station Identification

RSD

Recruiting Standards Directorate

RSM

Recruit Ship Month

RSP

Recruiting Standards Program

RSW

Recruit Ship Week

RWS

Recruiter Work Station

RZ

Recruiter Zone

SA

Security Assistant

SAC

Special Agreement Check

SBI

Special Background Investigation

SCI

Sensitive Compartmental Information

SDAP

Special Duty Allowance Pay

SGC

Senior Guidance Counselor

SI

Suspected Irregularities

SJA

Staff Judge Advocate

SLRP

Student Loan Repayment Program

SM

Screening Manager

SMP

Simultaneous Membership Program

SMT

Senior Master Trainer

SOP

Standing Operating Procedure

SPD

Separation Program Designator

SRIP

Selected Reserve Incentive Program

SSA

Social Security Administration

SSN

Social Security Number

ST

Security Technician

STP

Standard Training Program

SWAR

Ship without Advanced Reservation

Tech Check

Technical Check

Temp Res

Temporary reservation

TIN

Temporary Identification Number

TMR

Temporary Medical Rejection

TPU

Troop Program Unit

TRADOC

US Army Training and Doctrine Command

TS

Top Secret

TTHS

Trainees, Transients, Holdees, and Students

UCMJ

Uniformed Code of Military Justice

UIC

Unit Identification Code

USACC

United States Army Cadet Command

USACIDC

United States Army Criminal Investigation Division Command

USAR

United States Army Reserve

USARC

US Army Reserve Command

USAREC

US Army Recruiting Command

USARECBN

US Army Reception Battalion

USMEPCOM

U.S. Military Entrance Processing Command

VCN

Vacancy Control Number

WOCC

Warrant Officer Career College

WOFT

Warrant Officer Flight Training

XO

Executive Officer

1SG

First Sergeant

Section II Terms

Accession

- AC - An individual who has entered onto active duty status.
- RC - An individual who has enlisted into an Army Reserve program.

Administrative Investigation

An investigation conducted in accordance with chapter 5, AR 15-6, upon receipt of a credible allegation of RM by a prospect, applicant, recruit, or other person which occurs during the recruiting process, or when a PPT IO determines that sufficient evidence exists to warrant further inquiry into RM. An Administrative Investigation is required to substantiate RM.

Adverse Personnel Actions

Unfavorable personnel actions including, but not limited to, removal from recruiting duties, withdrawal of recruiting MOSC or additional skill identifier code, and/or letter of reprimand.

Active Duty Service Date

- NPS - Date entered onto active duty.
- PS - Date computed by taking current date entered onto active duty and subtracting from that date the years, months, and days of creditable active Federal service

Allegation

Information from any source, that a USAREC member violated this regulation and/or committed a Recruiting Irregularity. Allegations can be expressed or implied based on oral or written statements which need not be signed or sworn. Recruiting Irregularities also can be inferred based on documentary evidence. Applicant A person who has begun processing for enlistment, accession or Individual Ready Reserve transfer; into the RA or any other AR component of the Army.

Application for Enlistment - Armed Forces of the United States

The five pages of DD Form 1966. These pages along with the DD Form 4 series, DA Form 3286, SF 86, and verification documentation constitutes the enlistment record.

Appointing Authority

USAREC Cdrs at the Bn level or higher, USAREC Deputy Commanding General, and USAREC Chief of staff, are authorized to appoint informal investigations concerning allegations of RIs and other matters within their areas of responsibility. Only USAREC Commanding General, Deputy Commanding General, or Chief of Staff may authorize a headquarters investigation.

Approval Authority

The Commanding General, USAREC, or when empowered to act for the Commanding General the Deputy Commanding General USAREC.

Army Civilian Acquired Skills Program

Enlistment program allowing accelerated promotion dependent upon level of training or experience. The promotion to private first class is for secondary school level education or experience, and specialist and sergeant is for post-secondary level training or experience.

Army College Fund

Funds in addition to those provided by the All-Volunteer Forces Educational Assistance Program of 1984 (GI Bill).

Army Transmission Unit

An element of the processing section at the MEPS which collects, edits, and processes data for submission to USAREC, to enable maintenance of a computerized databank on all examinations and enlistments accomplished by MEPS.

Background Investigation

Consists of a full field background inquiry scoped from 5 to 15 years, or longer, and is required for U.S. citizens for a Top Secret clearance.

Basic Combat Training

Training for an accession (less those exempted IAW AR 612-201) which provides fundamental military knowledge.

Before Ship Record Check

Record check accomplished by a Guidance Counselor between 7 and 30 days prior to shipping to active duty or Initial Active Duty for Training.

Chief Medical Officer

Physician assigned as the Chief of the Medical Examination Section at MEPS, responsible for profiling and determination of medical eligibility for special programs (ex. airborne).

Coding

Alpha and numeric characters for assigned specific meanings which when entered into the service required and unique data blocks, allow for automatic data processing collection of historical information on every applicant and enlistee.

Completed Medical Evaluation

DD Form 2807-1 and DD Form 2808 which are complete and have been reviewed by the CMO to include profiling.

Cdrs Inquiry

Rules for Courts-Martial, Rule 303 Preliminary inquiry into reported offenses. Upon receipt of information that a member of the command is accused or suspected of committing an offense, the immediate commander shall make or cause to be made a preliminary inquiry into the charges or suspected offense.

Contract

A signed document specifying conditions, standards, and terms of enlistment into an Army program (see DD Form 4 series).

Control Activity

The activity within MEPS that controls applicant processing, directs individuals to various sections, and is usually under the supervision of the reception and orientation sergeant.

Courtesy Shipment

The accession of an individual previously processed at a different MEPS into the Future Soldier Training Program. Although the shipping Bn receives no enlistment credit, the Senior Guidance Counselor of the shipping Bn is responsible for ensuring the accuracy of the enlistment documents prior to shipment to a US Army Reception Bn.

Credential Laundering

Credential laundering is defined as recruiter advice or assistance provided to an applicant or prospect for the purpose of, or which has the effect of, converting or transferring a Tier 2 credential to a Tier 1 credential solely for the applicant or prospect to meet the Army's Tier 1 education enlistment requirements.

Currently in High School

A person currently in a high school grade other than senior; who has completed the 10th grade. This code is used for AR REQUEST purposes only.

Delayed Entry Program

An enlistment program which allows an individual to delay entry onto active duty for a period of up to 365 days. This program is subject to controls, as determined by the Commanding General, USAREC.

Diploma Mill

A diploma mill (also known as a degree mill) is an organization that awards academic degrees and secondary diplomas with substandard or no academic study and without recognition by official educational accrediting bodies.

The organization will offer academic degrees or secondary diplomas for a flat fee in a short amount of accreditations by non-recognized/unapproved accrediting bodies set up for the purposes of providing the appearance of authenticity.

Duplicate Reservation

Two or more reservations for the same applicant.

Early Ship

A Future Soldier Training Program enlistee brought onto active duty prior to the Recruit Ship Week within which his or her enlistment date falls. (Example: AIT class calls for an RSW of 8 October. The FS must enlist between 2 October (Tuesday) and 8 October (Monday). If an FS is brought onto active duty prior to 2 October without a reason, he or she is an early ship.)

Eligibility

Qualification for enlistment or appointment as a warrant or commissioned officer.

Elopement

Failure of a Future Soldier Training Program shipper to report to active duty by consciously going absent without leave.

Eloper

An individual who departs the MEPS with or without authorization prior to completion of processing and fails to return to complete processing.

Enlistee

A person who has taken the Oath of Enlistment into the Future Soldier Training Program, RA, any AR component of the Army and signed the applicable portions of DD Form 4 (Enlistment/Reenlistment Document - Armed Forces of the United States), or who has signed a request to transfer to a Troop Program Unit.

Enlistment

A voluntary contract (DD Form 4) for military service entered into between an individual and the Army which results in changing the status of the individual person from that of a civilian to that of a member of the military (RA or USAR). NOTE: For the purpose of this regulation, "enlistment" includes entry into the Future Soldier Training Program, original enlistment in a Troop Program Unit (with or without delay or split training), in the RA or appointment in the RA, AR, Officer Candidate School, Warrant Officer Flight Training, Chaplain, or Army Medical Department RA or AR. This includes transfers from the Individual Ready Reserve to a Troop Program Unit. Thus, the rules of this regulation apply both to all matters pertaining to enlistment in the Future Soldier Training Program and to all matters pertaining to the subsequent enlistment in the RA.

Enlistment Bonus

An amount of money determined by HQDA, which is paid to a qualified enlistee upon completion of Advanced Individual Training in selected MOSs. The amount of the Enlistment Bonus paid may depend on the Bn in which enlisted, the date of the original Future Soldier Training Program contract, MOS, and other factors determined by HQDA.

Enlistment Contract

A signed document specifying conditions, standards, and terms of enlistment into an Army program.

Enlistment Inquiry Section

Office established at HRC by direction of the Secretary of the Army to control MOSs and assignments of certain Prior Service applicants prior to enlistment or reenlistment.

Enlistment Record

The enlistment contract with associated and verifying documents broken down into six packets for distribution to various Army agencies

Erroneous Enlistment

An enlistment that later proves to be invalid because the individual failed to meet the qualifications prior to enlistment. Erroneous enlistment is not the result of fraudulent conduct on the part of the applicant.

Even flow

Attainment of DA-directed numbers of enlistments needed to maintain training centers at optimum level. Even flow also refers to a constant regulated flow of applicants to the MEPS to prevent overloading the MEPS.

Fee Basis Physician

A civilian medical doctor employed by MEPS to conduct medical examinations and/or consultations in MEPS.

Fraudulent Enlistment

An enlistment procured through a deliberate material misrepresentation, omission, or concealment of facts by a recruiter, Guidance Counselor, applicant, or any or all, which if known at the time of enlistment, would have resulted in rejection of the enlistee.

Future Soldier Training Program

A training program that prepares a Future Soldier for Initial Entry Training after enlisting into the RA or AR.

Formal Investigation

An administrative fact-finding procedure under AR 15-6 may be designated an investigation or a board of officers. Proceedings that involve more than one investigating officer using formal or informal procedures or a single investigating officer using formal procedures are designated a board of officers.

Future Soldier Training Program loss

A Future Soldier separation or voided contract.

Future Soldier Training Program separation

A separation from the Future Soldier Training Program through official published orders.

Future Soldier Training Program voided enlistment

A release from the Future Soldier Training Program through official published orders.

Guidance Counselor

Recruiter or civilian contractor assigned duties at the MEPS for enlistment processing of Army applicants.

Headquarters Investigation Team

The group of commissioned officers selected by the Chief of Staff, for training as USAREC Investigations Officers and for detail to investigative duties when allegations of RIs warrant an HQ USAREC investigation. Civilian employees and senior NCOs, sergeants first class through sergeants major, may be appointed as members of a headquarters investigative team. Only the USAREC Commanding General, Deputy Commanding General, or Chief of Staff may authorize a headquarters investigation.

High School Senior

A person enrolled in a program of education which, within 365 days, will result in meeting the definition of a High School Diploma Graduate contained in AR 601-210, 2-7.

Informal Investigation

An informal investigation or board may use whatever method it finds most efficient and effective for acquiring information. Although witnesses may be called to present formal testimony, information also may be obtained by personal interview, correspondence, telephone inquiry, or other informal means.

Inter-Service Recruitment Committee

A Bn level joint service committee established in the local area to coordinate and monitor aspects of applicant testing, processing, and educational liaison with high schools and the local community. One of its prime functions is planning and implementing the local school ASVAB testing program.

Late Cancellation

A reservation that is canceled after the scheduled enlistment date.

Late Ship

Future Soldier who enlist in the RA after the scheduled recruit ship date.

Live Scan

The electronic uploading of an applicant's FPs for electronic submission of Entrance National Agency Check.

Male or Female Impersonator

Improper gender coding. Reservation made for an applicant based on incorrect input of gender code.

Medical Waiver

An instrument for enlistment, which requires minimum documentation to warrant an exception to the physical standards established by AR 40-501. If a defect is considered to be disqualifying in accordance with the standards set forth in AR 40- 501, but is of such a nature as not to preclude the performance of duty, a waiver may be recommended by the Chief Medical Officer and submitted by the Bn.

MEPCOM Integrated Resource System

A USMEPCOM-wide system designed to collect, edit, and process information required to maintain a computerized databank on all processing accomplished by MEPS.

MEPS database listing

A computer listing of all records on the active file; sometimes referred to as the "dump listing."

MEPS jumper

An applicant who has processed and found to be disqualified (physically, morally, or mentally) at a MEPS, and subsequently processes at a different MEPS to conceal the original disqualification.

Midterm Graduate

This applies to the graduate who has met and/or exceeded prescribed requirements (units, credits) early. Graduation could occur at midterm (December to January) rather than the end (May to June) of the school term.

Military Entrance Processing Station

The joint service facility which conducts final PEs and final mental tests of all Selective Service registrants and service applicants, effects induction of enlistment processing, and ships such accessions to appropriate U.S. Army Reception Bns or duty stations.

Military Entrance Test Site

A location outside the MEPS used for the administration of the ASVAB. Either military or contracted test administrators may administer the test at the MET site.

Moral Waiver

An instrument for enlistment which requires documentation to warrant an exception to the enlistment standards established in AR 601-210. Waiver documentation should show that rehabilitation of the individual concerned has been demonstrated and that the individual is a good risk from a conduct standpoint, not to become a disciplinary problem during the term of enlistment.

National Agency Check and Local Check

A check accomplished by Office of Personnel Management, whereby, FBI Headquarters files, the FBI (Identification Division), FBI FP identification files, and local agencies, as appropriate, are checked for information on the designated individual. This check is required for Prior Service applicants. A National Agency Check is submitted on all Prior Service personnel unable to provide proof of their original Entrance National Agency Check status, regardless of break in service.

Non-High School Graduate

An individual who has earned neither a High School Diploma nor an equivalency certificate and is not attending school.

Non-Prior Service

For enlistment purposes (RA) an individual who has completed less than 180 days of active service in any armed service, (AR) and who is not MOS qualified.

No-Show

A processor who fails to report to a designated place for scheduled processing or enlistment.

Oath of Enlistment

Oath prescribed by statute and administered by a commissioned officer to each applicant who has been found qualified for, and desires, enlistment. An applicant orally subscribing to the oath and executing the DD Form 4 series becomes a member of the Armed Forces.

Pay Entry Base Date

The date, for pay purposes that an enlistee entered an armed service. For computation example see AR 601-210.

Phantom Reservation (bogus)

REQUEST reservation made for a fictitious applicant.

Physical Inspection

An abbreviated medical examination, given prior to entry into military service, to an individual who has received a complete medical examination within 18 months of the date of enlistment and was found acceptable. For entry into the Future Soldier Training Program or Delayed Status, if enlistment is accomplished within 30 days of the initial physical or last physical inspection, a new inspection is not required. For shipment onto active duty, if RA enlistment is accomplished within 72 hours of the initial physical or last physical inspection, a new inspection is not required.

Physical Profile Categories (PULHES)

Descriptive explanation of the Physical Evaluation divided into categories:

- P = General physical health
- U = Upper extremities
- L = Lower extremities
- H= Hearing and ears
- E = Vision and eyes
- S = Psychiatric

Positive Match ENTNAC

Individuals with derogatory information from Office of Personnel Management for law, credit, or citizenship.

Preliminary Inquiry (Cdrs Inquiry)

Rules for Courts-Martial, Rule 303 Preliminary inquiry into reported offenses. Upon receipt of information that a member of the command is accused or suspected of committing an offense, the immediate commander shall make or cause to be made a preliminary inquiry into the charges or suspected offense.

Processing Procedure Review

A preliminary inquiry conducted in a questionable situation in which a Recruiter Misconduct is possible based on circumstantial or documentary evidence.

Processing Section

A MEPS element responsible for administrative actions relative to the processing of applicants for enlistment or reenlistment into the Armed Forces.

Proprietary Schools

A proprietary college or university is one which operates as a private, profit seeking business. They emphasized applied education while minimizing traditional liberal arts education.

Prospect

An individual who has indicated interest in an enlistment to a recruiter directly or indirectly through face-to-face or telephonic communication or by Lead Evaluation and Distribution System, centers of influence (COI), Future Soldier Training Program referrals, and/or hometown recruiter aides.

Public Continuation School

A continuation school is an alternative school. Some school districts throughout the country use the term "continuation" and "alternative" interchangeably.

Qualification Test Material

Actual or illustrative questions and/or answers to any version of the test, or any other test administered to applicants for enlistment to determine test score qualification for enlistment; any component of these tests which would reveal actual questions and/or answers; and copies, written extracts, or crib sheets of test questions, answers, or any component of these tests which would reveal actual questions and answers.

Qualified Applicant

An applicant who has been mentally, medically, and morally evaluated, and found to be qualified for Army enlistment.

Qualified Military Available

Male citizens 17 to 21 years of age that are physically, mentally, and morally qualify for military service. Estimates of qualified military available may be calculated for county or other geographic area by applying experienced rejection rates to military available from the geographical area.

Qualified not Enlisted

An individual who is fully qualified and able to enlist, but declines to accept an available option.

Reasonable Commuting Distance

Distance from home to the AR center, within a 50-mile radius or 90-minute travel time.

Recruit Quota System

Centralized recruiting qualifications data, real-time training space and unit vacancy reservation capability, retrieval of operational and management data, and real-time message capability. REQUEST is an official reporting system for management information within USAREC.

Recruit Ship Date

The last day of the Recruit Ship Week. This day is always Monday, except as modified to accommodate the Christmas holiday schedule. This is the last day an individual may be enlisted so as to arrive at the Army Reception Bn in time for processing into the proper Basic Training and Basic Combat Training class.

Recruit Ship Month

A4 or 5-week period commencing on a Tuesday and ending on a Monday, not in consonance with a calendar month.

Recruit Ship Week

Tuesday through the following Monday is established as the Recruit Ship Week.

Recruiter Misconduct

The term Recruiter Misconduct is the equivalent of 'Recruiter Impropriety' or 'Recruiter Irregularity' to extent such terms are used in AR 601-1 and any related authority. Those intentional acts of misconduct where by the recruiter knowingly directed the fabrication, withholding or altering of applicant or enlistment information. Advising an applicant not to disclose pertinent information. Providing false information, or intentionally concealing information necessary to determine the eligibility, qualification, military entitlements, or certification of an applicant to enlist (or

enlist for a specialty, grade or rating) for which the applicant is not eligible; whereby perpetrated by a recruiter that involve a prospect, applicant, recruit, or member of the DEP, including sexual misconduct, sexual harassment, fraternization and unauthorized relationships, concealment or falsification, cheating on tests, and false promise or coercion. However, Recruiter Misconduct not specifically related to the enlistment process is outside the scope of this regulation. This includes sexual misconduct, sexual harassment, fraternization, and unauthorized relationships.

Recruiting Incentives Program

Those programs designed to attract high quality prospects or to induce enlistments in hard-to-fill MOSs or options (that is, the U.S. Army Cash Bonus Enlistment Option, and Loan Repayment Program).

Recruiting Irregularity

Those intentional or unintentional acts of omission and improprieties that are perpetrated by a recruiter, or alleged to be perpetrated by a recruiter, to facilitate the recruiting process for an applicant.

Red-Carpet Treatment

Procedures employed by the MEPS, which ensures that individuals receive personalized, efficient, and courteous service.

Reevaluation Believed Justified

A determination of the existence of a temporarily disqualifying medical condition, expected to improve in time.

Reinstatement

The restoration to recruiting duty status, along with a restoration of eligibility for Special Duty Allowance Pay.

REQUEST Reservation

One of the core programs of REQUEST which is the heart of the system. The REQUEST Program reserves an enlistment training space.

Residual Record

A record of each enlistment kept in the Enlist Record Management database consisting, at a minimum, of DA Form 3286, the DA Form 3540 (Certificate and Acknowledgment of US Army Reserve Service Requirements and Methods of Fulfillment), UF 601-210.13, DD Form 4 series, DD Form 1966 series, DD Form 2807-1, and DD Form 2808.

Reserve Officers' Training Corps Referral Program

A program whereby all elements of USAREC provide personal data on qualified applicants to Army Reserve Officers' Training Corps elements.

Retest

Any subsequent ASVAB test administered after the initial test during the validity period of the initial test. A retest is the only authorized means which may be used to qualify applicants for enlistment, whose initial test scores are not qualifying and do not reflect the applicant's true abilities and capabilities.

Ringer

An individual who attempts to process under a false name to qualify another individual for enlistment, who may otherwise not possess the ability to qualify.

Screening Manager

Person responsible for all matters pertaining to Entrance National Agency Check and National Agency Check policies and procedures as prescribed by this regulation.

Security Assistant

An individual who has the primary mission of screening, interviewing, counseling, and assisting in the processing of enlistees for all MOSs that are required to be cleared for sensitive positions.

Service Required Data and Service Unique Data

Any data element that is not a standard, where values of the data element vary among recruiting services.

Special Duty Assignment Pay

A monthly monetary incentive that is paid to enlisted personnel who qualify for and serve in designated special duty assignments. It is used for designated personnel who have extremely demanding duties that require an extraordinary effort for satisfactory performance or an unusual degree of responsibilities.

Ship

To transport an enlistee from MEPS to an Army Reception Bn.

Straight Shipper

An individual who enlists onto active duty without having entered the Future Soldier Training Program.

Suitability

Check of records of appropriate agencies such as the FBI, made by Office of Personnel Management, bearing on the loyalty and trustworthiness of an applicant.

Suspected Irregularity

Questionable situations in which a Recruiting Irregularity is possible based on circumstantial or documentary evidence.

Suspension

An exclusion from recruiting duty status for an indefinite period of time for the best interests of the Army. The recruiter is transferred from all duties involving contact with prospects and/or applicants for enlistments.

Technical Search

Electronic live scan fingerprint search of criminal indices.

Test Disqualified

An applicant who failed to achieve scores acceptable for enlistment as determined by specific criteria (that is, educational level, age, and category).

Test Management Section

Unit of MEPS which is responsible for administration of ASVAB tests developed for selection and classification purposes.

Test Qualified Declined

Individuals who have completed the ASVAB test and are qualified but decline further processing.

Umbrella School

School that enrolls homeschooling children or Families and offers services supportive of home education. This type of school is also known as a "Cover School"

Uncommitted Applicant Reservation

Reservation made for an individual who does not execute an enlistment agreement immediately.

Unfulfilled Enlistment

This enlistment occurs when a qualified applicant is properly enlisted, but who through no fault of his or her own cannot receive his or her original option or guarantee as contained on applicable DA Form 3286 and DD Form 4 series; or when the Army cannot honor an enlistment guarantee or promise, made in writing or verbally by a recruiting official, providing the communication of such guarantee or promise can be verified.

Unqualified Applicant

Any applicant found to be unqualified whether mentally, morally, or physically.

Volume II (VOL II)

Reports and retrieval of reports. The automated reporting system is used to monitor enlistment processing. The Recruiting Standards Management Reporting System (Volume II) contains a series of automated reports. This system provides raw information to analyze and identify units responsible for suspect enlistment processes. See

appendix B

Walk-In

A potential enlistee who walks into an RS without prior contact with a recruiter. Walk-in also refers to a person who arrives at the MEPS for processing without prior notification or being scheduled for processing.

USAREC

ELECTRONIC PUBLISHING SYSTEM

DATE: 20 JULY 2018
DOCUMENT: USAREC REG 601 – 210
SECURITY: UNCLASSIFIED
STATUS: REVISION